



# **AutoVu™ SharpZ3 Deployment Guide 13.1**

Document last updated: May 29, 2020

# Legal notices

---

©2020 Genetec Inc. All rights reserved.

Genetec Inc. distributes this document with software that includes an end-user license agreement and is furnished under license and may be used only in accordance with the terms of the license agreement. The contents of this document are protected under copyright law.

The contents of this guide are furnished for informational use only and are subject to change without notice. Genetec Inc. assumes no responsibility or liability for any errors or inaccuracies that may appear in the informational content contained in this guide.

This publication may not be copied, modified, or reproduced in any form or for any purpose, nor can any derivative works be created therefrom without Genetec Inc.'s prior written consent.

Genetec Inc. reserves the right to revise and improve its products as it sees fit. This document describes the state of a product at the time of document's last revision, and may not reflect the product at all times in the future.

In no event shall Genetec Inc. be liable to any person or entity with respect to any loss or damage that is incidental to or consequential upon the instructions found in this document or the computer software and hardware products described herein.

Genetec™, AutoVu™, AutoVu MLC™, Citywise™, Community Connect™, Curb Sense™, Federation™, Flexreader™, Genetec Airport Sense™, Genetec Citigraf™, Genetec Clearance™, Genetec ClearID™, Genetec Mission Control™, Genetec Motoscan™, Genetec Patroller™, Genetec Retail Sense™, Genetec Traffic Sense™, Omnicast™, Sipelia™, Stratocast™, Streamvault™, Synergis™, Valcri™, their respective logos, as well as the Mobius Strip Logo are trademarks of Genetec Inc., and may be registered or pending registration in several jurisdictions.

KiwiSecurity™, KiwiVision™, Privacy Protector™ and their respective logos are trademarks of KiwiSecurity Software GmbH, and may be registered or pending registration in several jurisdictions.

Other trademarks used in this document may be trademarks of the manufacturers or vendors of the respective products.

Patent pending. Genetec™ Security Center, Omnicast™, AutoVu™, Stratocast™, Citigraf™, Genetec Clearance™, and other Genetec™ products are the subject of pending patent applications, and may be the subject of issued patents, in the United States and in other jurisdictions worldwide.

All specifications are subject to change without notice.

## Document information

Document title: AutoVu™ SharpZ3 Deployment Guide 13.1

Original document number: EN.430.001-13.1B(1)

Document number: EN.430.001-13.1B(1)

Document update date: May 29, 2020

You can send your comments, corrections, and suggestions about this guide to [documentation@genetec.com](mailto:documentation@genetec.com).

# About this guide

---

This guide provides you with a complete source of information about how to install and configure an AutoVu™ SharpZ3 system.

You can customize your AutoVu™ SharpZ3 system to fit several different deployment types (for example, parking enforcement or law enforcement).

Depending on the type of deployment you require, you might not need to perform all of the steps listed in this document. For installation and configuration information related to your AutoVu™ solution, follow the steps in the appropriate deployment overview.

**WARNING:** Only AutoVu™-certified personnel should set up and install AutoVu™ systems. Read all of the procedures in this guide before installing an AutoVu™ system. Failure to follow the supplied instructions or information might result in loss of data or damage to hardware and will void the warranty.

## Notes and notices

The following notes and notices might appear in this guide:

- **Tip:** Suggests how to apply the information in a topic or step.
- **Note:** Explains a special case or expands on an important point.
- **Important:** Points out critical information concerning a topic or step.
- **Caution:** Indicates that an action or step can cause loss of data, security problems, or performance issues.
- **Warning:** Indicates that an action or step can result in physical harm, or cause damage to hardware.

**IMPORTANT:** Content in this guide that references information found on third-party websites was accurate at the time of publication, however, this information is subject to change without prior notice from Genetec Inc.

# Contents

---

## Preface

Legal notices . . . . .	ii
About this guide . . . . .	iii

## Chapter 1: Getting started

About Security Center AutoVu™ . . . . .	2
ALPR using machine learning . . . . .	3
Specifications for the SharpZ3 . . . . .	4
Genetec™ server configurations for AutoVu™ systems . . . . .	7
Storage requirement for ALPR images . . . . .	9
Supported ALPR contexts . . . . .	11
Supported plate origin recognition . . . . .	14
About the AutoVu™ deployment questionnaire . . . . .	15

## Chapter 2: Deployment overviews

About the deployment overviews . . . . .	17
About law enforcement . . . . .	18
Law enforcement deployment overview . . . . .	18
About university parking enforcement . . . . .	21
University parking enforcement deployment overview . . . . .	21
About city parking enforcement . . . . .	25
City parking enforcement deployment overview . . . . .	25
About overtime parking enforcement . . . . .	29
Overtime parking enforcement deployment overview . . . . .	29
About MLPI systems . . . . .	33
MLPI enforcement deployment overview . . . . .	33

## Chapter 3: About SharpZ3 hardware installation

Hardware components for a SharpZ3 installation . . . . .	37
Required tools and parts for a SharpZ3 installation . . . . .	39
Wire ferrules for SharpZ3 installations . . . . .	41
Conductor arrangements for SharpZ3 cameras . . . . .	42

## Chapter 4: Module installation

Installing the ALPR module . . . . .	44
About SharpZ3 expansion modules . . . . .	45
Installing expansion modules . . . . .	46
Navigation expansion module connections . . . . .	48
Aux PoE expansion module connections . . . . .	50

## Chapter 5: Base unit installation

Base unit installation . . . . .	52
Best practices for mounting the base unit . . . . .	52
Connecting the ignition signal . . . . .	55
Connecting power to the base unit . . . . .	56
Power management in a SharpZ3 system . . . . .	57

Installing the base unit cooler pack . . . . .	58
About the trunk unit cable racks . . . . .	60

## Chapter 6: Camera installation

About camera mounting . . . . .	63
Hardmount camera installation . . . . .	64
Preparing the vehicle for a hardmounted camera installation . . . . .	64
Installing the hardmount on the vehicle for SharpZ3 cameras . . . . .	66
Attaching the SharpZ3 pan/tilt/roll bracket to the hardmount . . . . .	67
Installing the SharpZ3 camera using the magmount . . . . .	69
Lightbar camera installation . . . . .	71
About the lightbar bracket . . . . .	71
Installing the SharpZ3 camera on a lightbar . . . . .	72
Drilling a camera cable hole . . . . .	75
SharpZ3 cabling recommendations . . . . .	76
Camera cable connection . . . . .	77
Terminating the SharpZ3 camera cable . . . . .	77
Conductor arrangements for SharpZ3 cameras . . . . .	79
Connecting the camera cable . . . . .	80
Base unit camera connections . . . . .	81
Sealing cable holes in the patrol vehicle . . . . .	83
Camera alignment . . . . .	84
Alignment scenarios for SharpZ3 cameras . . . . .	84
Attaching the target to the tripod . . . . .	86
Setting up the tripod . . . . .	86
Aligning the SharpZ3 cameras with the target . . . . .	88

## Chapter 7: Peripheral hardware installation

About SharpZ3 navigation hardware . . . . .	90
Satellite navigation hardware options . . . . .	90
Installing the SharpZ3 satellite navigation hardware . . . . .	91
Installing the GlobalSat GPS driver . . . . .	92
About the odometry sensor . . . . .	92
Installing the odometry sensor . . . . .	93
Installing the cellular antenna . . . . .	96
About installing wheel-imaging cameras in a SharpZ3 system . . . . .	98
Wheel-imaging camera location . . . . .	98
Drilling the mounting and cabling holes for your wheel-imaging camera . . . . .	99
Installing a wheel-imaging camera . . . . .	100
About the AutoVu™ car camera switch . . . . .	106
AutoVu™ car camera switch wiring . . . . .	106
Mounting the AutoVu™ car camera switch . . . . .	107

## Chapter 8: In-vehicle computer installation

ToughPad computer installation . . . . .	109
Installing the ToughPad base mount . . . . .	109
Assembling the tele-pole and lower swing arm . . . . .	110
Assembling the tilt-pivot head . . . . .	111
Attaching the tablet mount to the tilt-pivot head . . . . .	115
Attaching the ToughPad dock and keyboard tray to the tablet mount . . . . .	116

About powering the in-vehicle computer . . . . .	118
<b>Chapter 9: Introduction to the Sharp portal</b>	
About the Sharp Portal . . . . .	120
Logging on to the Sharp Portal . . . . .	121
Changing your logon password in the Sharp Portal . . . . .	125
Sharp Portal interface overview . . . . .	126
Viewing camera feeds . . . . .	128
SharpZ3 hardware inventory . . . . .	130
Rebooting the SharpZ3 ALPR module . . . . .	131
Synchronizing the SharpZ3 clock . . . . .	132
Configuring battery monitoring . . . . .	133
<b>Chapter 10: SharpZ3 camera configuration</b>	
Security configuration in the Sharp Portal . . . . .	136
Installing the SharpZ3 auto-generated certificate . . . . .	136
Installing a self-signed certificate . . . . .	138
Installing a signed certificate . . . . .	140
About SharpZ3 exposure adjustment . . . . .	142
Setting custom SharpZ3 ALPR camera exposure levels . . . . .	142
Troubleshooting outdoor exposure issues for the SharpZ3 ALPR camera . . . . .	143
Troubleshooting outdoor exposure issues for the SharpZ3 context camera . . . . .	144
Configuring SharpZ3 position and location . . . . .	145
Associating wheel-imaging cameras with SharpZ3 camera units . . . . .	147
Configuring SharpZ3 analytics . . . . .	150
Configuring where the SharpZ3 sends its ALPR data . . . . .	152
SharpZ3 communication ports . . . . .	153
About SharpZ3 network settings . . . . .	154
Configuring the SharpZ3 system to use a specific IP address range . . . . .	155
Configuring the SharpZ3 FTP extension . . . . .	158
Modifications you can make to the SharpZ3 FTP XML template . . . . .	159
Configuring the SharpZ3 HTTP/HTTPS extension . . . . .	161
Examples of JSON and XML ALPR events for the SharpZ3 HTTP extension . . . . .	162
Configuring Syslog for SharpZ3 log files . . . . .	165
Importing and exporting settings . . . . .	166
<b>Chapter 11: Completing the deployment</b>	
Completing the deployment . . . . .	169
<b>Chapter 12: Troubleshooting the installation</b>	
LED status on the SharpZ3 camera unit . . . . .	171
Resetting a lost password for the Sharp Portal . . . . .	174
<b>Chapter 13: Updating the system</b>	
Updating a Sharp unit from the SharpOS 13 Sharp Portal . . . . .	177
<b>Chapter 14: Sharp Portal reference</b>	
Sharp Portal - Overview page . . . . .	181
Sharp Portal - Camera feeds page . . . . .	183
Sharp Portal - Inventory page . . . . .	185
Sharp Portal - Network page . . . . .	186

Sharp Portal - Security page . . . . .	187
Sharp Portal - Exposure page . . . . .	189
Sharp Portal - Position and orientation page . . . . .	190
Sharp Portal - Auxiliary cameras page . . . . .	191
Sharp Portal - ALPR settings page . . . . .	192
Sharp Portal - Extension page . . . . .	193
Sharp Portal - Product improvement program page . . . . .	195
Sharp Portal - Recovery page . . . . .	196
Sharp Portal - Date and time page . . . . .	197
Sharp Portal - Power options page . . . . .	198
Sharp Portal - Maintenance page . . . . .	199
Sharp Portal - Logs page . . . . .	200
Sharp Portal - Log sources page . . . . .	201
<b>Glossary . . . . .</b>	<b>202</b>
<b>Where to find product information . . . . .</b>	<b>218</b>
<b>Technical support . . . . .</b>	<b>219</b>

# Getting started

This section includes the following topics:

- ["About Security Center AutoVu™"](#) on page 2
- ["ALPR using machine learning"](#) on page 3
- ["Specifications for the SharpZ3 "](#) on page 4
- ["Genetec™ server configurations for AutoVu™ systems"](#) on page 7
- ["Storage requirement for ALPR images"](#) on page 9
- ["Supported ALPR contexts"](#) on page 11
- ["Supported plate origin recognition"](#) on page 14
- ["About the AutoVu™ deployment questionnaire"](#) on page 15



## About Security Center AutoVu™

The AutoVu™ automatic license plate recognition (ALPR) system automates license plate reading and identification, making it easier for law enforcement and for municipal and commercial organizations to locate vehicles of interest and enforce parking restrictions. Designed for both fixed and mobile installations, the AutoVu™ system is ideal for a variety of applications and entities, including law enforcement, municipal, and commercial organizations.

Depending on the Sharp hardware you install, you can use AutoVu™ in a fixed configuration such as on a pole in a parking lot, or in a mobile configuration such as on a patrol vehicle.

You can use AutoVu™ for the following:

- Scofflaw and wanted vehicle identification
- City-wide surveillance
- Parking enforcement
- Parking permit control
- Vehicle inventory
- Security
- Access control

### AutoVu™ system architecture

AutoVu™ Sharp cameras capture license plate images, and send the data to Genetec Patroller™ or Security Center to verify against lists of vehicles of interest (hotlists) and vehicles with permits (permit lists).

The following diagram shows how a typical AutoVu™ system works:

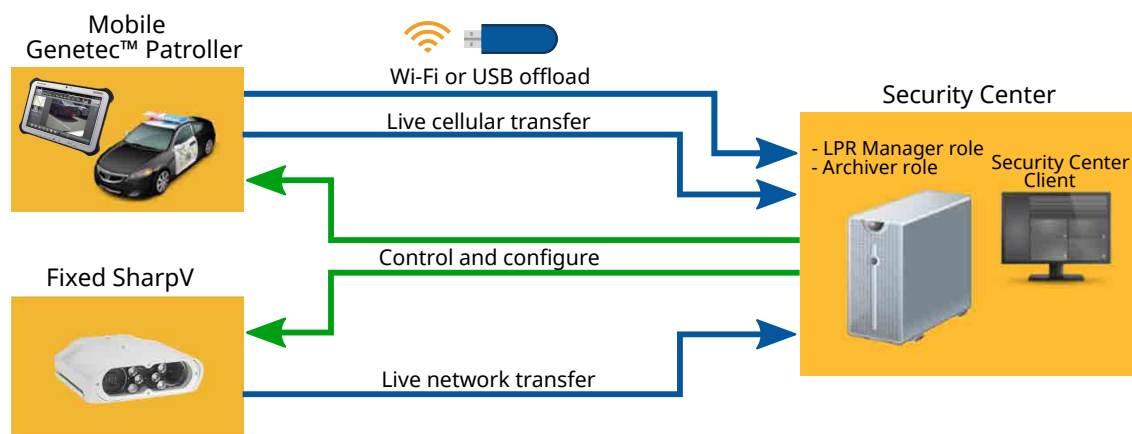

### Example

Watch this video to learn more. Click the **Captions** icon (CC) to turn on video captions in one of the available languages. If using Internet Explorer, the video might not display. To fix this, open the **Compatibility View Settings** and clear **Display intranet sites in Compatibility View**.



## ALPR using machine learning

---

Sharp systems running SharpOS 13 use machine learning to classify license plates and to perform character recognition.

### **AutoVu MLC™**

AutoVu MLC™ (Machine Learning Core) replaces traditional rule-based ALPR technology with machine learning-based algorithms to reduce common ALPR misreads and false positives. It is a proprietary technology of Genetec Inc. used in AutoVu™ Sharp hardware for license plate recognition.

Although off-the-shelf machine learning solutions are commercially available for ALPR, their results can be unpredictable. With our hardware and software engineering expertise, we have built the AutoVu MLC™ from the ground up. This includes developing a deep neural network (DNN), training the system with Sharp camera images, and optimizing the system to run on AutoVu™ hardware. The AutoVu MLC™ represents a significant reduction in the time that operators spend manually correcting plate reads.

As the AutoVu™ MLC continues to develop, we will apply it to more aspects of the ALPR process. You will be able to take advantage of these improvements with future SharpOS releases.

# Specifications for the SharpZ3

Refer to the technical, mechanical, and environmental specifications when planning and deploying a SharpZ3 system.

## SharpZ3 camera specifications

Specification	Details
<b>ALPR camera sensors</b>	1456(H) x 1088(V) progressive scan @30fps, monochrome, global shutter
<b>ALPR capture range</b>	Up to 63-foot (19-meter) range with retro-reflective license plates
<b>ALPR camera lens options</b>	8mm, 12mm, 16mm, 25mm
<b>Context camera sensor</b>	<ul style="list-style-type: none"> <li>• 1456(H) x 1088(V) progressive scan @30 fps</li> <li>• Color</li> <li>• B&amp;W night mode with 940nm illuminator</li> <li>• Global shutter</li> <li>• JPEG still images and MJPEG video streaming</li> </ul>
<b>Context camera lens</b>	Based on ALPR lens configuration: 4mm, 6mm, 8mm, 12mm
<b>Illuminator</b>	<ul style="list-style-type: none"> <li>• Pulsed LED illuminator (740nm, 850nm, 940nm, 590nm)</li> </ul>
<b>Water-resistance   sealing</b>	IEC 60529 IPx6, IPx7   IEC 60529 IP6x
<b>Dimensions</b>	1.65 (h) x 5.12 (w) x 3.56 (d) inches (4.2 x 13 x 9 cm)   Excludes cabling and mounting bracket
<b>Weight</b>	1.2 lbs (0.54 kg)
<b>Color</b>	Available in black/white

## SharpZ3 base unit specifications

Specification	Details
<b>I/O</b>	Base unit: 2x 10/100/1000 Base-T Ethernet ports (RJ45) 4x digital inputs (triggers), 0~32Vdc, opto-coupled 4x dry-contact outputs (relays): 2x 0.25A solid state relays, 2x 8A electromechanical relays 1x regulated 12V AUX output power, 200ma
<b>Mounting options</b>	Horizontal and vertical
<b>Dimensions</b>	3.6 (h) x 8.6 (w) x 9.3 (d) inches (9.1 x 21.8 x 23.6 cm). Excludes cabling, cable racks and mounting brackets

Specification	Details
<b>Weight</b>	Base unit: 4.4 lbs (2.0 kg) ALPR module: 2-ports: 4.1 lbs (1.9 kg) ALPR module: 4-ports: 4.4 lbs (2.0 kg)
<b>Processors</b>	Intel Atom Processor E3950 Intel Myriad X VPU (machine-learning co-processor)
<b>Power</b>	12/24Vdc nominal (9 to 32 Vdc) <b>Optional modules:</b> 2x ALPR base unit module: Typical power consumption: 50W 4x ALPR base unit module: Typical power consumption: 98W

### SharpZ3 system certification (camera and base unit)

Specification	Details
<b>Vibration</b>	IEC 60068-2-64
<b>Shock resistance</b>	IEC 60068-2-27
<b>Electromagnetic immunity and emissions</b>	FCC part 15 Sub-part B   ICES-003 Issue 4   CISPR32 / EN55032   CISPR35 / EN55035   CISPR25 / EN55025   EN 50498
<b>CE marking</b>	EMC Directive 2014/30/EU; Automotive EMC Directive 2004/104/EC; RoHS Directive 2011/65/EU
<b>Temperature</b>	-40°F to 122°F (-40°C to 50°C) operating; -40°F to 185°F (-40°C to 85°C) storage -40°F to 149°F (-40°C to 65°C) base unit operating, w/optional cooling pack Certifications: IEC 60068-2-1 Category Ad   IEC 60068-2-2 Category Bd   IEC 60068-2-14 Category Na Includes hi-temp auto-shutoff protection

### Part numbers

AU-Z3-W-12F12F-850

Ⓐ   Ⓑ   Ⓒ   Ⓓ   Ⓔ

Component	Signification
A	SharpZ3 prefix
B	Color: <b>W</b> (white) or <b>B</b> (black)

Component	Signification	
C	Primary ALPR lens:	<ul style="list-style-type: none"><li>• <b>Focal length:</b> 8 mm, 12 mm, 16 mm, 25 mm</li></ul>
D	Secondary ALPR lens:	<ul style="list-style-type: none"><li>• <b>Filter:</b> F: Monochrome sensor with filter M: Monochrome sensor without filter C: Color sensor with filter</li></ul>
E	LED	<ul style="list-style-type: none"><li>• <b>Illumination:</b> 590 nm, 740 nm, 850 nm, 940 nm</li></ul>

---

# Genetec™ server configurations for AutoVu™ systems

Depending on the requirements of the system, you can install the AutoVu™ system on one server or distribute the load over multiple servers.

## Single server

In a single-server system, the LPR Manager, Archiver, and Directory roles are configured on the same server. For better performance, you can configure separate Archiver roles for ALPR and video.

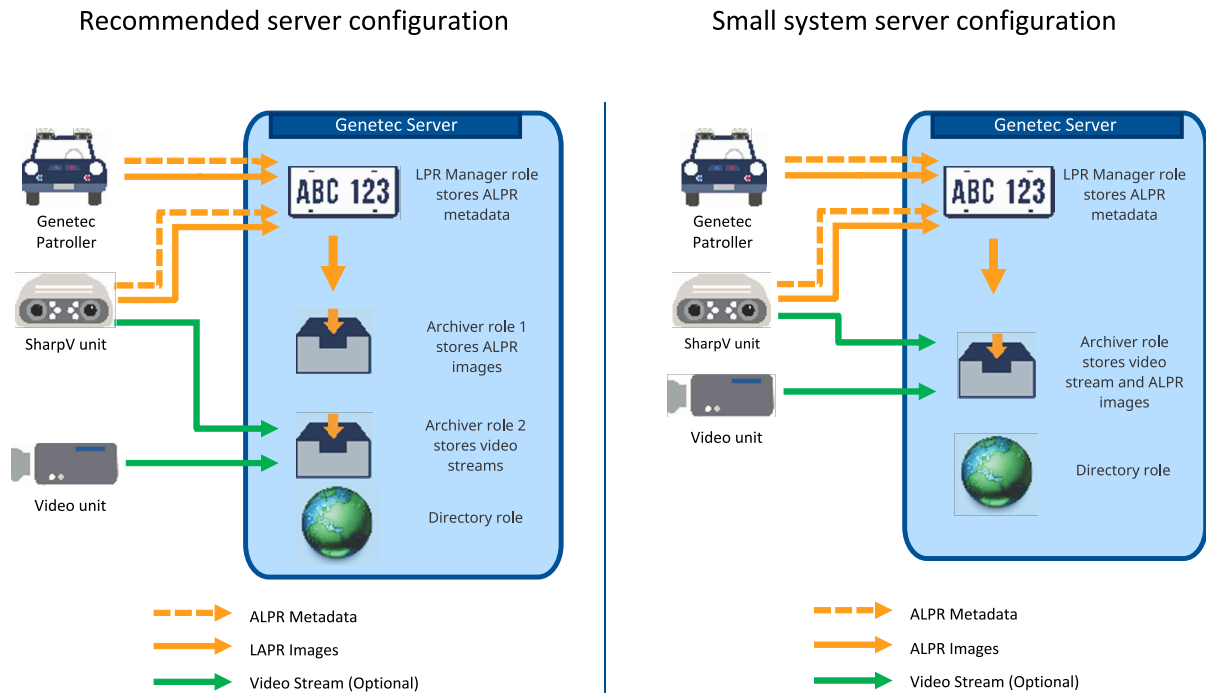

## Multiple servers

In a multiple-server system, the Archiver role is installed on a separate server from the LPR Manager and Directory roles. For better performance, you can configure separate Archiver roles for ALPR and video.

### Recommended server configuration

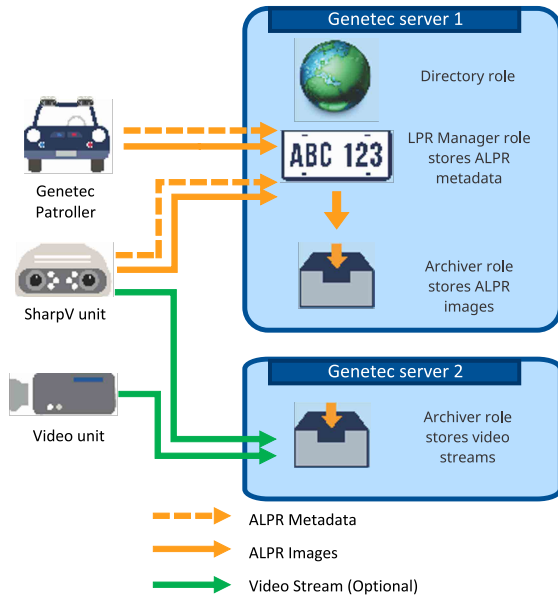

### Small system server configuration

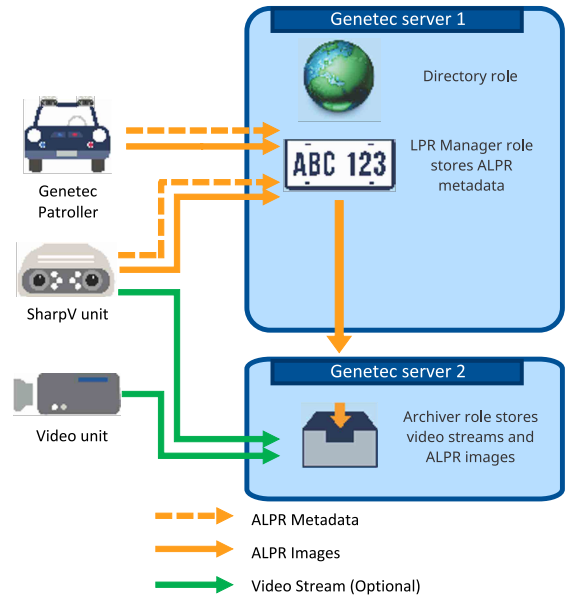

## Storage requirement for ALPR images

The images associated with the reads and hits are stored on disk in G64 files by an Archiver. You can estimate the disk space required to store these images if you know the average number of reads and hits processed by the LPR Manager per day.

For every license plate read or hit processed by the LPR Manager, the Archiver stores a set of four images:

- One context camera image (in either high resolution or low resolution)
- One ALPR camera image (cropped to show only the license plate)
- One context camera thumbnail image
- One ALPR camera thumbnail image

The size of the image set depends on the model of the Sharp camera and whether the context camera is configured to take images in high resolution or low resolution.

Use the following formula to estimate the disk space you need for the desired image retention periods.

$$\text{Disk space} = (\text{ReadsPD} \times \text{ImageSize} \times \text{ReadIRP}) + (\text{HitsPD} \times \text{ImageSize} \times \text{HitIRP})$$

where:

- **ReadsPD:** Average number of reads per day.
- **ImageSize:** Estimated image size per read (depends on the Sharp model and configuration).
- **ReadIRP:** Read image retention period (see LPR Manager's **Properties** tab).
- **HitsPD:** Average number of hits per day.
- **HitIRP:** Hit image retention period (see LPR Manager's **Properties** tab).

If your patrol vehicles are equipped with wheel imaging cameras, double the number of hits per day in your formula (there is typically one wheel image per hit).

The following table gives you the rough estimates of the image size per read based on the Sharp model and configuration.

Type of image	Sharp VGA or XGA	SharpV	SharpZ3
<b>High-resolution configuration</b>			
Context camera image	~50 KB	~120 KB	~160 KB
ALPR camera image (cropped)	~3 KB	~3 KB	~2 KB
Context camera thumbnail image	~3 KB	~3 KB	~2 KB
ALPR camera thumbnail image	~1 KB	~1 KB	~1 KB
<b>Total image size per read:</b>	~57 KB	~127 KB	~165 KB
<b>Low-resolution configuration</b>			
Context camera image	~18 KB	-	-
ALPR camera image (cropped)	~3 KB	~3 KB	-
Context camera thumbnail image	~3 KB	~3 KB	-



Type of image	Sharp VGA or XGA	SharpV	SharpZ3
ALPR camera thumbnail image	~1 KB	~1 KB	-
<b>Total image size per read:</b>	~25 KB	-	-

## Supported ALPR contexts

---

ALPR contexts are created for specific regions in order to optimize ALPR for the license plates of that region.

### Asia-Pacific

**NOTE:** To help us improve the performance of regional contexts, click **Configuration > Connectivity > Product improvement** and register this camera to participate in the **Product improvement program**.

ALPR contexts are available for the following license plates:

- Australia (optimized for New South Wales)
- Hong Kong
- India
- Japan
- Mongolia
- Northern territory (Australia)
- New Zealand
- Queensland (Australia)
- Singapore
- Sri Lanka<sup>20</sup>
- Turkmenistan
- Vietnam
- Western Australia

### Caribbean and Latin America

- Argentina
- ArgentinaMulti<sup>17</sup>
- Bahamas
- Bermuda
- Brazil
- Cayman Islands
- Chile
- Colombia
- Costa Rica
- Dominican Republic
- Mexico
- Mexico Jalisco
- Paraguay
- Peru
- St-Maarten

### Europe/Middle East/Africa

- Abu Dhabi
- Abu Dhabi WithPrefix<sup>18</sup>
- Algeria
- Arabic Peninsula<sup>1</sup>
- Azerbaijan
- Bahrain
- Belgium<sup>9</sup>
- BelgiumMulti<sup>10</sup>
- BelgiumMultiVanity<sup>11</sup>
- Denmark
- Dubai
- DubaiWithPrefix<sup>18</sup>
- Europe<sup>2</sup>
- Europe One and Two Lines<sup>3</sup>
- France
- Great Britain
- General European context
- Germany
- Iceland
- Ireland
- Italy
- Ivory Coast
- Jordan
- Kazakhstan
- Kuwait
- Lebanon
- Monaco
- Morocco
- Netherlands
- Norway
- Oman<sup>4</sup>
- Poland
- Portugal
- Qatar
- QatarMilitary<sup>12</sup>
- Romania
- Saudi Arabia
- Sharjah
- Sharjah WithPrefix<sup>18</sup>
- Slovakia
- South Africa
- Spain
- Sweden
- Switzerland
- Turkey
- TurkeyOnly<sup>13</sup>
- United Arab Emirates<sup>5</sup>
- United Arab Emirates WithPrefix<sup>18</sup>

## North America

- Alabama
- Alberta
- Arizona
- British Columbia
- British Columbia Fixed<sup>14</sup>
- California
- Colorado
- Connecticut
- Delaware
- Florida
- General US context
- Georgia
- Georgia\_3Chars<sup>21</sup>
- Hawaii
- Idaho
- Illinois
- Indiana
- Iowa
- Kansas
- Kentucky
- KentuckyIndiana
- Louisiana
- Maine
- Manitoba
- Maryland
- Massachusetts
- MassachusettsIR<sup>15</sup>
- Michigan
- Minnesota
- Mississippi
- Montana
- Nebraska
- Nevada
- New Brunswick
- Newfoundland
- New Hampshire
- New Jersey
- New Mexico
- New York
- New York City<sup>16</sup>
- North Carolina
- North Dakota
- Northeast states<sup>6</sup>
- Nova Scotia
- Ohio
- Oklahoma
- Ontario
- Oregon
- Pennsylvania
- PennsylvaniaDelaware<sup>6</sup>
- Prince Edward Island
- Quebec
- Rhode Island
- Saskatchewan
- South Carolina
- South Dakota
- Tennessee
- Texas
- Utah and Neighbors<sup>8</sup>
- Vermont
- Virginia
- Washington State<sup>19</sup>
- Wisconsin
- Wyoming
- Yukon

<sup>1</sup>Includes Saudi Arabia, Bahrain, Kuwait, and UAE.

<sup>2</sup>General European context for one-line plates.

<sup>3</sup>General European context for one-line and two-line plates.

<sup>4</sup>Only standard Omani plates are supported (wide-format, black-on-white, and black-on-yellow). License plates issued by neighboring countries are not supported.

<sup>5</sup>Includes Abu Dhabi, Dubai, and Sharjah plates.

<sup>6</sup>Includes Delaware, New York, Pennsylvania, and Vermont plates.

<sup>7</sup>Includes Pennsylvania, Delaware, Florida, Vermont, and New York plates.

<sup>8</sup>Includes Utah, Oregon, Montana, and North Dakota plates.

<sup>9</sup>Supports one-line plates with five or more characters.

<sup>10</sup>Supports one-line and two-line plates with five or more characters.

<sup>11</sup>Supports one-line and two-line plates with three or more characters. Note that this context can produce many false positive reads.

<sup>12</sup>Exposure settings are optimized for non-reflective military plates. Note that performance with standard plates might be reduced.

<sup>13</sup>Excludes the letters Q, W, and X. Note that foreign plates that contain these characters are not read correctly.

<sup>14</sup>Optimized for fixed installations.

<sup>15</sup>Optimized for SharpZ3 cameras with 850nm IR illuminators.

<sup>16</sup>Exposure settings are optimized for non-reflective taxi plates. Note that performance with standard plates might be reduced.

<sup>17</sup>Supports standard and motorcycle plates.

<sup>18</sup>*WithPrefix* includes characters that are present on the plate, but are separate from the license plate read.

<sup>19</sup>Specialized ALPR contexts available for ABMER (590 nm) and IR (850nm) illuminators.

<sup>20</sup>Supports Latin characters only.

<sup>21</sup>Supports plates with three or more characters. Note that using this context might increase the false positive count.

## Supported plate origin recognition

---

In addition to reading the number on a license plate, the SharpZ3 can also read the state, province, or country. Plate origin recognition is performed on a best-effort basis, and is not necessarily available for the same plates that have a supported ALPR context.

Plate origin recognition is supported for the following plates:

### Europe/Middle East/Africa

- Abu Dhabi (AD)
- Ajman (AJ)
- Bahrain (BRN)
- Belgium (B)
- Denmark (DK)
- Dubai (DUB)
- France (F)
- Fujairah (FUJ)
- Germany (D)
- Great Britain (GB)
- Italy (I)
- Kuwait (KWT)
- Netherlands (NL)
- Norway (N)
- Poland (PL)
- Portugal (P)
- Ras al Khaimah (RAK)
- Romania (RO)
- Saudi Arabia (KSA)
- Sharjah (SHJ)
- Slovakia (SK)
- Switzerland (CH)
- Spain (E)
- Umm al Qaiwain (UAQ)

### North America

- Alabama (AL)
- Alberta (AB)
- Arizona (AZ)
- Arkansas (AR)
- British Columbia (BC)
- California (CA)
- Colorado (CO)
- Connecticut (CT)
- Delaware (DE)
- District of Columbia (DC)
- Florida (FL)
- Georgia (GA)
- Hawaii (HI)
- Idaho (ID)
- Illinois (IL)
- Indiana (IN)
- Iowa (IA)
- Kansas (KS)
- Kentucky (KY)
- Louisiana (LA)
- Maine (ME)
- Manitoba (MB)
- Maryland (MD)
- Massachusetts (MA)
- Michigan (MI)
- Minnesota (MN)
- Mississippi (MS)
- Missouri (MO)
- Montana (MT)
- Nebraska (NE)
- Nevada (NV)
- New Brunswick (NB)
- Newfoundland and Labrador (NL)
- New Hampshire (NH)
- New Jersey (NJ)
- New Mexico (NM)
- New York (NY)
- North Carolina (NC)
- North Dakota (ND)
- Nova Scotia (NS)
- Ohio (OH)
- Oklahoma (OK)
- Ontario (ON)
- Oregon (OR)
- Pennsylvania (PA)
- Price Edward Island (PEI)
- Rhode Island (RI)
- Quebec (QC)
- Saskatchewan (SK)
- South Carolina (SC)
- South Dakota (SD)
- Tennessee (TN)
- Texas (TX)
- US Government (GOV)
- Utah (UT)
- Vermont (VT)
- Virginia (VA)
- Washington (WA)
- West Virginia (WV)
- Wisconsin (WI)
- Wyoming (WY)
- Yukon (YT)

## About the AutoVu™ deployment questionnaire

---

The *AutoVu™ Deployment Questionnaire* helps you establish the requirements and basic functionality of the AutoVu™ system. It must be filled out before you go on site to deploy an AutoVu™ system.

The questionnaire is available from your AutoVu™ representative and is a very useful tool for planning your deployment.

For example, the questionnaire will help you determine the following:

- In what city is the system being used?
- Is overtime enforcement being used?
- Do the by-laws require evidence (wheel images) that a vehicle has not moved?
- Are hotlists being enforced?
- Is Pay-by-Plate integration required?
- Are there special requirements for the project?
- How many permit zones are there?
- Does the computer that will be running the Security Center server application meet the minimum requirements?
- Does the computer that will be running the Security Center client applications meet the minimum requirements?
- Does the in-vehicle computer that will be running the Genetec Patroller™ application meet the minimum requirements?
- What are the SQL database requirements?

# Deployment overviews

This section includes the following topics:

- ["About the deployment overviews"](#) on page 17
- ["About law enforcement"](#) on page 18
- ["About university parking enforcement"](#) on page 21
- ["About city parking enforcement"](#) on page 25
- ["About overtime parking enforcement"](#) on page 29
- ["About MLPI systems"](#) on page 33

## About the deployment overviews

---

You can customize your AutoVu™ SharpZ3 system to fit several different deployment types (for example, parking enforcement or law enforcement).

Depending on the type of deployment you require, you might not need to perform all of the steps listed in this document. For installation and configuration information related to your AutoVu™ solution, follow the steps in the appropriate deployment overview.

The following deployment overviews are available for AutoVu™ SharpZ3 systems. If you are not sure of which deployment overview to use, contact your AutoVu™ representative.



## About law enforcement

The law enforcement solution is recommended for applications where you are only interested in comparing reads to a simple hotlist of wanted vehicles, such as vehicles with unpaid registrations or outstanding tickets.

The law enforcement solution does not support permit or time-limit enforcement.

### Law enforcement deployment overview

This deployment guide provides information for all SharpZ3 deployment types. Use the following deployment overview to install and configure a SharpZ3 system for law enforcement.

#### Preparing for the deployment

These are the tasks to perform before you go on site for the deployment. If you cannot complete the tasks on this checklist, contact your AutoVu™ representative.

Step	Task	Description	Where to find more information
1	Fill out the <i>AutoVu™ Deployment Questionnaire</i> .	The questionnaire helps you collect the information required to deploy the system.	<ul style="list-style-type: none"> <li><a href="#">About the AutoVu™ deployment questionnaire on page 15</a></li> </ul>
2	Read the product related release notes.	The release notes contain information about the current releases, as well as any known issues or limitations.	<ul style="list-style-type: none"> <li><a href="#">Security Center Release Notes</a></li> <li><a href="#">Sharp Release Notes</a></li> <li><a href="#">Genetec Patroller™ Release Notes</a></li> </ul>
3	Install Security Center.	Security Center receives reads from Genetec Patroller™ software.	<ul style="list-style-type: none"> <li><a href="#">Installing Security Center.</a></li> </ul> <p>For more information, see the <i>Security Center Installation and Upgrade Guide</i>.</p>
4	(Optional) Install BeNomad maps.	BeNomad provides the SharpZ3 system with maps and reverse geocoding information.	<ul style="list-style-type: none"> <li><a href="#">Installing the BeNomad mapping solution for Security Center</a></li> <li><a href="#">Installing BeNomad files on the in-vehicle computer</a></li> <li>For more information, see the <i>Security Center Administrator Guide</i>.</li> </ul>
5	Configure the LPR Manager role in Security Center.	The LPR Manager is the role that manages and controls the patrol vehicles running Genetec Patroller™ software.	<ul style="list-style-type: none"> <li><a href="#">Configuring LPR Manager roles</a></li> </ul> <p>For more information, see the <i>Security Center Administrator Guide</i>.</p>

Step	Task	Description	Where to find more information
6	Configure the Archiver role in Security Center.	The Archiver is the role that stores video streams and ALPR images.	<ul style="list-style-type: none"> <li><a href="#">Setting up the Archiver role for ALPR</a></li> </ul> <p>For more information, see the <i>Security Center Administrator Guide</i>.</p>
7	(Optional) Configure hotlists.	To use hotlist entities in Security Center, you must create the hotlist, map it to a source text file, and configure it for your enforcement scenario.	<ul style="list-style-type: none"> <li><a href="#">Create hotlists</a></li> </ul> <p>For more information, see the <i>Security Center Administrator Guide</i>.</p>

## On site tasks

These are the tasks to perform while on site. If you can't complete the tasks on this checklist, contact your AutoVu™ representative.

Step	Task	Description	Where to find more information
1	Install expansion modules.	Depending on the deployment type you might need to install one or more expansion modules in the SharpZ3 base unit.	<ul style="list-style-type: none"> <li><a href="#">About SharpZ3 expansion modules</a> on page 45</li> </ul>
2	Install the SharpZ3 base unit in the vehicle.	You can mount the base unit anywhere inside the vehicle that is safe, secure, and has good airflow.	<ul style="list-style-type: none"> <li><a href="#">Base unit installation</a> on page 52</li> </ul>
3	Install peripheral hardware.	In addition to the SharpZ3 base unit and cameras, you must install hardware that is associated with vehicle odometry or with SharpZ3 expansion modules.	<ul style="list-style-type: none"> <li><a href="#">Navigation hardware options</a></li> <li><a href="#">Installing the SharpZ3 satellite navigation hardware</a></li> <li><a href="#">Installing the GlobalSat GPS driver</a></li> <li><a href="#">Installing the odometry sensor</a></li> <li><a href="#">Installing the cellular antenna</a></li> <li><a href="#">Installing the car camera switch</a></li> </ul>
4	Install the SharpZ3 cameras on the vehicle.	Depending on the hardware ordered, systems can support either two or four SharpZ3 cameras.	<ul style="list-style-type: none"> <li><a href="#">About camera mounting</a> on page 63</li> </ul>
5	Install and configure the in-vehicle computer.	The in-vehicle computer must be powered through the base unit's auxiliary 8A Max relay.	<ul style="list-style-type: none"> <li><a href="#">ToughPad computer installation</a> on page 109</li> </ul>

Step	Task	Description	Where to find more information
6	Install a certificate to secure the Sharp Portal.	SharpZ3 cameras must communicate using TLS encryption (HTTPS) using either the certificate that is auto-generated on the SharpZ3, a new self-signed certificate, or a signed certificate from your own public key infrastructure (PKI) or from a Certificate Authority such as VeriSign.	<ul style="list-style-type: none"> <li>• <a href="#">Installing the SharpZ3 auto-generated certificate</a> on page 136</li> <li>• <a href="#">Installing a self-signed certificate</a> on page 138</li> <li>• <a href="#">Installing a signed certificate</a> on page 140</li> </ul>
7	Configure the positions of the SharpZ3 cameras.	Based on the location of the patrol vehicle and the position of the SharpZ3 cameras, the system can calculate the location of the target vehicle.	<ul style="list-style-type: none"> <li>• <a href="#">Configuring SharpZ3 position and location</a> on page 145</li> </ul>
8	Configure SharpZ3 analytics.	You can configure which plates the SharpZ3 will read, and whether the system should attempt to read the plate origin, vehicle make, vehicle type and color, and so on.	<ul style="list-style-type: none"> <li>• <a href="#">Configuring SharpZ3 analytics</a> on page 150</li> </ul>
9	Install Genetec Patroller™.	Genetec Patroller™ is the AutoVu™ software application installed on an in-vehicle computer. Genetec Patroller™ connects to Security Center and is controlled by the LPR Manager.	<ul style="list-style-type: none"> <li>• <a href="#">Installing Genetec Patroller™</a></li> </ul> <p>For more information, see the <i>Genetec Patroller™ Administrator Guide</i>.</p>
10	Connect the SharpZ3 system to Genetec Patroller™.	If Genetec Patroller™ does not connect to Security Center, you must offload license plate reads manually using a USB key.	<ul style="list-style-type: none"> <li>• <a href="#">Configuring where the SharpZ3 sends its ALPR data</a> on page 152</li> </ul>
11	Configure Genetec Patroller™.	There are many tasks that must be performed to configure Genetec Patroller™, such as configuring your offload settings, connecting to Security Center, and so on.	<ul style="list-style-type: none"> <li>• <a href="#">Configuring Genetec Patroller™</a></li> </ul> <p>For more information, see the <i>Genetec Patroller™ Administrator Guide</i>.</p>
12	Align the SharpZ3 cameras.	You must align your SharpZ3 cameras using the AutoVu™ Alignment Kit so they can read plates accurately.	<ul style="list-style-type: none"> <li>• <a href="#">Camera alignment</a> on page 84</li> </ul>
13	Complete the installation.	At the end of the installation you should test the system to ensure that the hardware is functional, and perform a read report to test performance.	<ul style="list-style-type: none"> <li>• <a href="#">Completing the deployment</a> on page 169</li> </ul>

# About university parking enforcement

The university parking enforcement solution is recommended for customers with advanced permit enforcement scenarios and is designed around enforcement zones.

When the patrol vehicle enters a zone, the system identifies all valid permits based on the zone and the current schedule, and compiles all valid license plate numbers into a single list. Zone-based occupancy reports are available. The university solution supports shared permits, where a single permit is shared between multiple registered vehicles. Shared permit infractions work on a user-configurable timer. The university solution also supports time-limit enforcement, but cannot enforce permits and time-limit rules simultaneously. Customers requiring simultaneous permit and time-limit enforcement should opt for the city or overtime solution. The university solution supports integration with third-party ticketing systems and is compatible with AutoVu™ Pay-by-Plate Sync.

## University parking enforcement deployment overview

There are many tasks involved in deploying a SharpZ3 system for university parking enforcement. Use this overview as a reference to guide you through the process.

### Preparing for the deployment

These are the tasks to perform before you go on site for the deployment. If you cannot complete the tasks on this checklist, contact your AutoVu™ representative.

Step	Task	Description	Where to find more information
1	Fill out the <i>AutoVu™ Deployment Questionnaire</i> .	The questionnaire helps you collect the information required to deploy the system.	<ul style="list-style-type: none"> <li><a href="#">About the AutoVu™ deployment questionnaire on page 15</a></li> </ul>
2	Read the product related release notes.	The release notes contain information about the current releases, as well as any known issues or limitations.	<ul style="list-style-type: none"> <li><a href="#">Security Center Release Notes</a></li> <li><a href="#">Sharp Release Notes</a></li> <li><a href="#">Genetec Patroller™ Release Notes</a></li> </ul>
3	Install Security Center.	Security Center receives reads from Genetec Patroller™ software.	<ul style="list-style-type: none"> <li><a href="#">Installing Security Center.</a></li> </ul> <p>For more information, see the <i>Security Center Installation and Upgrade Guide</i>.</p>
4	Install BeNomad maps.	BeNomad provides the SharpZ3 system with maps and reverse geocoding information.	<ul style="list-style-type: none"> <li><a href="#">Installing the BeNomad mapping solution for Security Center</a></li> <li><a href="#">Installing BeNomad files on the in-vehicle computer</a></li> <li>For more information, see the <i>Security Center Administrator Guide</i>.</li> </ul>

Step	Task	Description	Where to find more information
5	Install Pay-by-Plate Sync.	If Pay-by-Plate Sync is being used to consolidate multiple third-party license plate-enabled parking (LEP) systems, install the Pay-by-Plate Sync plugin on the Security Center server.	<ul style="list-style-type: none"> <li><a href="#">Deploying Pay-by-Plate Sync</a></li> </ul> For more information, see the <i>Pay-by-Plate Sync Plugin Guide</i> .
6	Configure the LPR Manager role in Security Center.	The LPR Manager is the role that manages and controls the patrol vehicles running Genetec Patroller™ software.	<ul style="list-style-type: none"> <li><a href="#">Configuring LPR Manager roles</a></li> </ul> For more information, see the <i>Security Center Administrator Guide</i> .
7	Configure the Archiver role in Security Center.	The Archiver is the role that stores video streams and ALPR images.	<ul style="list-style-type: none"> <li><a href="#">Setting up the Archiver role for ALPR</a></li> </ul> For more information, see the <i>Security Center Administrator Guide</i> .
8	Configure permits in Security Center.	A permit defines a single parking permit holder list.	<ul style="list-style-type: none"> <li><a href="#">Creating permits</a></li> </ul> For more information, see the <i>Security Center Administrator Guide</i> .
9	Configure permit restrictions in Security Center.	you must also assign <a href="#">permit restrictions</a> and parking lots to create an enforcement “zone” that is downloaded to Genetec Patroller™.	<ul style="list-style-type: none"> <li><a href="#">Creating permit restrictions</a></li> </ul> For more information, see the <i>Security Center Administrator Guide</i> .
10	Configure parking lots.	You must configure an enforcement area (or parking lot) for each enforcement rule (permit, or overtime rule) that you create.	<ul style="list-style-type: none"> <li><a href="#">Configure parking lots</a></li> </ul> For more information, see the <i>Security Center Administrator Guide</i> .
11	(Optional) Configure hotlists.	To use hotlist entities in Security Center, you must create the hotlist, map it to a source text file, and configure it for your enforcement scenario.	<ul style="list-style-type: none"> <li><a href="#">Create hotlists</a></li> </ul> For more information, see the <i>Security Center Administrator Guide</i> .

## On site tasks

These are the tasks to perform while on site. If you can't complete the tasks on this checklist, contact your AutoVu™ representative.

Step	Task	Description	Where to find more information
1	Install expansion modules.	Depending on the deployment type you might need to install one or more expansion modules in the SharpZ3 base unit.	<ul style="list-style-type: none"> <li><a href="#">About SharpZ3 expansion modules</a> on page 45</li> </ul>

Step	Task	Description	Where to find more information
2	Install the SharpZ3 base unit in the vehicle.	You can mount the base unit anywhere inside the vehicle that is safe, secure, and has good airflow.	<ul style="list-style-type: none"> <li>• <a href="#">Base unit installation</a> on page 52</li> </ul>
3	Install peripheral hardware.	In addition to the SharpZ3 base unit and cameras, you must install hardware that is associated with vehicle odometry or with SharpZ3 expansion modules.	<ul style="list-style-type: none"> <li>• <a href="#">Navigation hardware options</a></li> <li>• <a href="#">Installing the SharpZ3 satellite navigation hardware</a></li> <li>• <a href="#">Installing the GlobalSat GPS driver</a></li> <li>• <a href="#">Installing the odometry sensor</a></li> <li>• <a href="#">Installing the cellular antenna</a></li> <li>• <a href="#">Installing the car camera switch</a></li> </ul>
4	Install the SharpZ3 cameras on the vehicle.	Depending on the hardware ordered, systems can support either two or four SharpZ3 cameras.	<ul style="list-style-type: none"> <li>• <a href="#">About camera mounting</a> on page 63</li> </ul>
5	Install and configure the in-vehicle computer.	The in-vehicle computer must be powered through the base unit's auxiliary <i>8A Max</i> relay.	<ul style="list-style-type: none"> <li>• <a href="#">ToughPad computer installation</a> on page 109</li> </ul>
6	Install a certificate to secure the Sharp Portal.	SharpZ3 cameras must communicate using TLS encryption (HTTPS) using either the certificate that is auto-generated on the SharpZ3, a new self-signed certificate, or a signed certificate from your own public key infrastructure (PKI) or from a Certificate Authority such as VeriSign.	<ul style="list-style-type: none"> <li>• <a href="#">Installing the SharpZ3 auto-generated certificate</a> on page 136</li> <li>• <a href="#">Installing a self-signed certificate</a> on page 138</li> <li>• <a href="#">Installing a signed certificate</a> on page 140</li> </ul>
7	Configure the positions of the SharpZ3 cameras.	Based on the location of the patrol vehicle and the position of the SharpZ3 cameras, the system can calculate the location of the target vehicle.	<ul style="list-style-type: none"> <li>• <a href="#">Configuring SharpZ3 position and location</a> on page 145</li> </ul>
8	Configure SharpZ3 analytics.	You can configure which plates the SharpZ3 will read, and whether the system should attempt to read the plate origin, vehicle make, vehicle type and color, and so on.	<ul style="list-style-type: none"> <li>• <a href="#">Configuring SharpZ3 analytics</a> on page 150</li> </ul>
9	Install Genetec Patroller™.	Genetec Patroller™ is the AutoVu™ software application installed on an in-vehicle computer. Genetec Patroller™ connects to Security Center and is controlled by the LPR Manager.	<ul style="list-style-type: none"> <li>• <a href="#">Installing Genetec Patroller™</a></li> </ul> <p>For more information, see the <i>Genetec Patroller™ Administrator Guide</i>.</p>

Step	Task	Description	Where to find more information
10	Connect the SharpZ3 system to Genetec Patroller™.	If Genetec Patroller™ does not connect to Security Center, you must offload license plate reads manually using a USB key.	<ul style="list-style-type: none"> <li>• <a href="#">Configuring where the SharpZ3 sends its ALPR data</a> on page 152</li> </ul>
11	Configure Genetec Patroller™.	There are many tasks that must be performed to configure Genetec Patroller™, such as configuring your offload settings, connecting to Security Center, and so on.	<ul style="list-style-type: none"> <li>• <a href="#">Configuring Genetec Patroller™</a></li> </ul> <p>For more information, see the <i>Genetec Patroller™ Administrator Guide</i>.</p>
12	(Optional) Install the T2 eTicketBook plugin.	If the T2 eTicketBook will be used with Pay-by-Plate, the eTicketBook plugin needs to be installed on the in-vehicle computer.	<ul style="list-style-type: none"> <li>• Contact your T2 representative, they will install eTicketBook for you.</li> </ul>
13	Align the SharpZ3 cameras.	You must align your SharpZ3 cameras using the AutoVu™ Alignment Kit so they can read plates accurately.	<ul style="list-style-type: none"> <li>• <a href="#">Camera alignment</a> on page 84</li> </ul>
14	Complete the installation.	At the end of the installation you should test the system to ensure that the hardware is functional, and perform a read report to test performance.	<ul style="list-style-type: none"> <li>• <a href="#">Completing the deployment</a> on page 169</li> </ul>

## About city parking enforcement

The city parking enforcement solution is recommended for customers requiring simultaneous permit and time-limit enforcement capabilities.

Where the university solution is designed around enforcement zones, the city solution is designed around permit categories. As such, operators must select a permit category to enforce. Because of this, schedule-based restrictions are unavailable. The city solution cannot enforce more than one permit category at a time, and does not currently support shared permits. The city parking enforcement solution supports integration with third-party ticketing systems and is compatible with AutoVu™ Pay-by-Plate Sync.

When the patrol vehicle is equipped with wheel-imaging cameras, the city parking enforcement solution can perform long-term (2 to 5 days) time-limit enforcement.

### City parking enforcement deployment overview

There are many tasks involved in deploying a SharpZ3 system for city parking enforcement. Use this overview as a reference to guide you through the process.

#### Preparing for the deployment

These are the tasks to perform before you go on site for the deployment. If you cannot complete the tasks on this checklist, contact your AutoVu™ representative.

Step	Task	Description	Where to find more information
1	Fill out the <i>AutoVu™ Deployment Questionnaire</i> .	The questionnaire helps you collect the information required to deploy the system.	<ul style="list-style-type: none"> <li><a href="#">About the AutoVu™ deployment questionnaire</a> on page 15</li> </ul>
2	Read the product related release notes.	The release notes contain information about the current releases, as well as any known issues or limitations.	<ul style="list-style-type: none"> <li><a href="#">Security Center Release Notes</a></li> <li><a href="#">Sharp Release Notes</a></li> <li><a href="#">Genetec Patroller™ Release Notes</a></li> </ul>
3	Install Security Center.	Security Center receives reads from Genetec Patroller™ software.	<ul style="list-style-type: none"> <li><a href="#">Installing Security Center.</a></li> </ul> <p>For more information, see the <i>Security Center Installation and Upgrade Guide</i>.</p>
4	Install BeNomad maps.	BeNomad provides the SharpZ3 system with maps and reverse geocoding information.	<ul style="list-style-type: none"> <li><a href="#">Installing the BeNomad mapping solution for Security Center</a></li> <li><a href="#">Installing BeNomad files on the in-vehicle computer</a></li> <li>For more information, see the <i>Security Center Administrator Guide</i>.</li> </ul>
5	Install Pay-by-Plate Sync.	If Pay-by-Plate Sync is being used to consolidate multiple third-party license plate-enabled parking (LEP) systems, install the Pay-by-Plate Sync plugin on the Security Center server.	<ul style="list-style-type: none"> <li><a href="#">Deploying Pay-by-Plate Sync</a></li> </ul> <p>For more information, see the <i>Pay-by-Plate Sync Plugin Guide</i>.</p>



Step	Task	Description	Where to find more information
6	Configure the LPR Manager role in Security Center.	The LPR Manager is the role that manages and controls the patrol vehicles running Genetec Patroller™ software.	<ul style="list-style-type: none"> <li><a href="#">Configuring LPR Manager roles</a></li> </ul> For more information, see the <i>Security Center Administrator Guide</i> .
7	Configure the Archiver role in Security Center.	The Archiver is the role that stores video streams and ALPR images.	<ul style="list-style-type: none"> <li><a href="#">Setting up the Archiver role for ALPR</a></li> </ul> For more information, see the <i>Security Center Administrator Guide</i> .
8	Configure permits in Security Center.	A permit defines a single parking permit holder list.	<ul style="list-style-type: none"> <li><a href="#">Creating permits</a></li> </ul> For more information, see the <i>Security Center Administrator Guide</i> .
9	Configure parking lots.	You must configure an enforcement area (or parking lot) for each enforcement rule (permit, or overtime rule) that you create.	<ul style="list-style-type: none"> <li><a href="#">Configure parking lots</a></li> </ul> For more information, see the <i>Security Center Administrator Guide</i> .
10	(Optional) Configure hotlists.	To use hotlist entities in Security Center, you must create the hotlist, map it to a source text file, and configure it for your enforcement scenario.	<ul style="list-style-type: none"> <li><a href="#">Create hotlists</a></li> </ul> For more information, see the <i>Security Center Administrator Guide</i> .

## On site tasks

These are the tasks to perform while on site. If you can't complete the tasks on this checklist, contact your AutoVu™ representative.

Step	Task	Description	Where to find more information
1	Install expansion modules.	Depending on the deployment type you might need to install one or more expansion modules in the SharpZ3 base unit.	<ul style="list-style-type: none"> <li><a href="#">About SharpZ3 expansion modules</a> on page 45</li> </ul>
2	Install the SharpZ3 base unit in the vehicle.	You can mount the base unit anywhere inside the vehicle that is safe, secure, and has good airflow.	<ul style="list-style-type: none"> <li><a href="#">Base unit installation</a> on page 52</li> </ul>
3	Install peripheral hardware.	In addition to the SharpZ3 base unit and cameras, you must install hardware that is associated with vehicle odometry or with SharpZ3 expansion modules.	<ul style="list-style-type: none"> <li><a href="#">Navigation hardware options</a></li> <li><a href="#">Installing the SharpZ3 satellite navigation hardware</a></li> <li><a href="#">Installing the GlobalSat GPS driver</a></li> <li><a href="#">Installing the odometry sensor</a></li> <li><a href="#">Installing the cellular antenna</a></li> <li><a href="#">Installing the car camera switch</a></li> </ul>

Step	Task	Description	Where to find more information
4	Install the SharpZ3 cameras on the vehicle.	Depending on the hardware ordered, systems can support either two or four SharpZ3 cameras.	<ul style="list-style-type: none"> <li>• <a href="#">About camera mounting</a> on page 63</li> </ul>
5	(Optional) Install wheel-imaging cameras on the vehicle.	If the system includes the AUX PoE expansion module, you can install wheel-imaging cameras to perform virtual tire-chalking.	<ul style="list-style-type: none"> <li>• <a href="#">About installing wheel-imaging cameras in a SharpZ3 system</a> on page 98</li> </ul>
6	Install and configure the in-vehicle computer.	The in-vehicle computer must be powered through the base unit's auxiliary 8A Max relay.	<ul style="list-style-type: none"> <li>• <a href="#">ToughPad computer installation</a> on page 109</li> </ul>
7	Install a certificate to secure the Sharp Portal.	SharpZ3 cameras must communicate using TLS encryption (HTTPS) using either the certificate that is auto-generated on the SharpZ3, a new self-signed certificate, or a signed certificate from your own public key infrastructure (PKI) or from a Certificate Authority such as VeriSign.	<ul style="list-style-type: none"> <li>• <a href="#">Installing the SharpZ3 auto-generated certificate</a> on page 136</li> <li>• <a href="#">Installing a self-signed certificate</a> on page 138</li> <li>• <a href="#">Installing a signed certificate</a> on page 140</li> </ul>
8	Configure the positions of the SharpZ3 cameras.	Based on the location of the patrol vehicle and the position of the SharpZ3 cameras, the system can calculate the location of the target vehicle.	<ul style="list-style-type: none"> <li>• <a href="#">Configuring SharpZ3 position and location</a> on page 145</li> </ul>
9	Associate wheel-imaging cameras.	If the SharpZ3 system includes wheel-imaging cameras, you must associate them with their corresponding SharpZ3 camera units.	<ul style="list-style-type: none"> <li>• <a href="#">Associating wheel-imaging cameras with SharpZ3 camera units</a> on page 147</li> </ul>
10	Configure SharpZ3 analytics.	You can configure which plates the SharpZ3 will read, and whether the system should attempt to read the plate origin, vehicle make, vehicle type and color, and so on.	<ul style="list-style-type: none"> <li>• <a href="#">Configuring SharpZ3 analytics</a> on page 150</li> </ul>
11	Install Genetec Patroller™.	Genetec Patroller™ is the AutoVu™ software application installed on an in-vehicle computer. Genetec Patroller™ connects to Security Center and is controlled by the LPR Manager.	<ul style="list-style-type: none"> <li>• <a href="#">Installing Genetec Patroller™</a></li> </ul> <p>For more information, see the <i>Genetec Patroller™ Administrator Guide</i>.</p>
12	Connect the SharpZ3 system to Genetec Patroller™.	If Genetec Patroller™ does not connect to Security Center, you must offload license plate reads manually using a USB key.	<ul style="list-style-type: none"> <li>• <a href="#">Configuring where the SharpZ3 sends its ALPR data</a> on page 152</li> </ul>

Step	Task	Description	Where to find more information
13	Configure Genetec Patroller™.	There are many tasks that must be performed to configure Genetec Patroller™, such as configuring your offload settings, connecting to Security Center, and so on.	<ul style="list-style-type: none"> <li><a href="#">Configuring Genetec Patroller™</a></li> </ul> For more information, see the <i>Genetec Patroller™ Administrator Guide</i> .
14	(Optional) Install the T2 eTicketBook plugin.	If the T2 eTicketBook will be used with Pay-by-Plate, the eTicketBook plugin needs to be installed on the in-vehicle computer.	<ul style="list-style-type: none"> <li>Contact your T2 representative, they will install eTicketBook for you.</li> </ul>
15	Align the SharpZ3 cameras.	You must align your SharpZ3 cameras using the AutoVu™ Alignment Kit so they can read plates accurately.	<ul style="list-style-type: none"> <li><a href="#">Camera alignment</a> on page 84</li> </ul>
16	Complete the installation.	At the end of the installation you should test the system to ensure that the hardware is functional, and perform a read report to test performance.	<ul style="list-style-type: none"> <li><a href="#">Completing the deployment</a> on page 169</li> </ul>

# About overtime parking enforcement

The overtime parking enforcement solution shares the same feature set as the city solution and adds support for wheel imaging when performing time-limit enforcement.

The wheel imaging feature increases the accuracy of time-limit enforcement operations and takes additional photographic evidence of infractions. The overtime solution supports integration with third-party ticketing systems and is compatible with AutoVu™ Pay-by-Plate Sync.

## Overtime parking enforcement deployment overview

There are many tasks involved in deploying a SharpZ3 system for overtime parking enforcement. Use this overview as a reference to guide you through the process.

### Preparing for the deployment

These are the tasks to perform before you go on site for the deployment. If you cannot complete the tasks on this checklist, contact your AutoVu™ representative.

Step	Task	Description	Where to find more information
1	Fill out the <i>AutoVu™ Deployment Questionnaire</i> .	The questionnaire helps you collect the information required to deploy the system.	<ul style="list-style-type: none"> <li>• <a href="#">About the AutoVu™ deployment questionnaire</a> on page 15</li> </ul>
2	Read the product related release notes.	The release notes contain information about the current releases, as well as any known issues or limitations.	<ul style="list-style-type: none"> <li>• <a href="#">Security Center Release Notes</a></li> <li>• <a href="#">Sharp Release Notes</a></li> <li>• <a href="#">Genetec Patroller™ Release Notes</a></li> </ul>
3	Install Security Center.	Security Center receives reads from Genetec Patroller™ software.	<ul style="list-style-type: none"> <li>• <a href="#">Installing Security Center</a>.</li> </ul> <p>For more information, see the <i>Security Center Installation and Upgrade Guide</i>.</p>
4	Install BeNomad maps.	BeNomad provides the SharpZ3 system with maps and reverse geocoding information.	<ul style="list-style-type: none"> <li>• <a href="#">Installing the BeNomad mapping solution for Security Center</a></li> <li>• <a href="#">Installing BeNomad files on the in-vehicle computer</a></li> <li>• For more information, see the <i>Security Center Administrator Guide</i>.</li> </ul>
5	Install Pay-by-Plate Sync.	If Pay-by-Plate Sync is being used to consolidate multiple third-party license plate-enabled parking (LEP) systems, install the Pay-by-Plate Sync plugin on the Security Center server.	<ul style="list-style-type: none"> <li>• <a href="#">Deploying Pay-by-Plate Sync</a></li> </ul> <p>For more information, see the <i>Pay-by-Plate Sync Plugin Guide</i>.</p>

Step	Task	Description	Where to find more information
6	Configure the LPR Manager role in Security Center.	The LPR Manager is the role that manages and controls the patrol vehicles running Genetec Patroller™ software.	<ul style="list-style-type: none"> <li><a href="#">Configuring LPR Manager roles</a></li> </ul> For more information, see the <i>Security Center Administrator Guide</i> .
7	Configure the Archiver role in Security Center.	The Archiver is the role that stores video streams and ALPR images.	<ul style="list-style-type: none"> <li><a href="#">Setting up the Archiver role for ALPR</a></li> </ul> For more information, see the <i>Security Center Administrator Guide</i> .
8	Configure permits in Security Center.	A permit defines a single parking permit holder list.	<ul style="list-style-type: none"> <li><a href="#">Creating permits</a></li> </ul> For more information, see the <i>Security Center Administrator Guide</i> .
9	Configure overtime rules.	An overtime rule defines a parking time limit and the maximum number of violations enforceable within a single day.	<ul style="list-style-type: none"> <li><a href="#">Create overtime rules</a></li> </ul> For more information, see the <i>Security Center Administrator Guide</i> .
10	Configure parking lots.	You must configure an enforcement area (or parking lot) for each enforcement rule (permit, or overtime rule) that you create.	<ul style="list-style-type: none"> <li><a href="#">Configure parking lots</a></li> </ul> For more information, see the <i>Security Center Administrator Guide</i> .
11	(Optional) Configure hotlists.	To use hotlist entities in Security Center, you must create the hotlist, map it to a source text file, and configure it for your enforcement scenario.	<ul style="list-style-type: none"> <li><a href="#">Create hotlists</a></li> </ul> For more information, see the <i>Security Center Administrator Guide</i> .

## On site tasks

These are the tasks to perform while on site. If you can't complete the tasks on this checklist, contact your AutoVu™ representative.

Step	Task	Description	Where to find more information
1	Install expansion modules.	Depending on the deployment type you might need to install one or more expansion modules in the SharpZ3 base unit.	<ul style="list-style-type: none"> <li><a href="#">About SharpZ3 expansion modules</a> on page 45</li> </ul>
2	Install the SharpZ3 base unit in the vehicle.	You can mount the base unit anywhere inside the vehicle that is safe, secure, and has good airflow.	<ul style="list-style-type: none"> <li><a href="#">Base unit installation</a> on page 52</li> </ul>

Step	Task	Description	Where to find more information
3	Install peripheral hardware.	In addition to the SharpZ3 base unit and cameras, you must install hardware that is associated with vehicle odometry or with SharpZ3 expansion modules.	<ul style="list-style-type: none"> <li>• <a href="#">Navigation hardware options</a></li> <li>• <a href="#">Installing the SharpZ3 satellite navigation hardware</a></li> <li>• <a href="#">Installing the GlobalSat GPS driver</a></li> <li>• <a href="#">Installing the odometry sensor</a></li> <li>• <a href="#">Installing the cellular antenna</a></li> <li>• <a href="#">Installing the car camera switch</a></li> </ul>
4	Install the SharpZ3 cameras on the vehicle.	Depending on the hardware ordered, systems can support either two or four SharpZ3 cameras.	<ul style="list-style-type: none"> <li>• <a href="#">About camera mounting on page 63</a></li> </ul>
5	Install wheel-imaging cameras on the vehicle.	If the system includes the AUX PoE expansion module, you can install wheel-imaging cameras to perform virtual tire-chalking.	<ul style="list-style-type: none"> <li>• <a href="#">About installing wheel-imaging cameras in a SharpZ3 system on page 98</a></li> </ul>
6	Install and configure the in-vehicle computer.	The in-vehicle computer must be powered through the base unit's auxiliary <i>8A Max</i> relay.	<ul style="list-style-type: none"> <li>• <a href="#">ToughPad computer installation on page 109</a></li> </ul>
7	Install a certificate to secure the Sharp Portal.	SharpZ3 cameras must communicate using TLS encryption (HTTPS) using either the certificate that is auto-generated on the SharpZ3, a new self-signed certificate, or a signed certificate from your own public key infrastructure (PKI) or from a Certificate Authority such as VeriSign.	<ul style="list-style-type: none"> <li>• <a href="#">Installing the SharpZ3 auto-generated certificate on page 136</a></li> <li>• <a href="#">Installing a self-signed certificate on page 138</a></li> <li>• <a href="#">Installing a signed certificate on page 140</a></li> </ul>
8	Configure the positions of the SharpZ3 cameras.	Based on the location of the patrol vehicle and the position of the SharpZ3 cameras, the system can calculate the location of the target vehicle.	<ul style="list-style-type: none"> <li>• <a href="#">Configuring SharpZ3 position and location on page 145</a></li> </ul>
9	Associate wheel-imaging cameras.	If the SharpZ3 system includes wheel-imaging cameras, you must associate them with their corresponding SharpZ3 camera units.	<ul style="list-style-type: none"> <li>• <a href="#">Associating wheel-imaging cameras with SharpZ3 camera units on page 147</a></li> </ul>
10	Configure SharpZ3 analytics.	You can configure which plates the SharpZ3 will read, and whether the system should attempt to read the plate origin, vehicle make, vehicle type and color, and so on.	<ul style="list-style-type: none"> <li>• <a href="#">Configuring SharpZ3 analytics on page 150</a></li> </ul>

Step	Task	Description	Where to find more information
11	Install Genetec Patroller™.	Genetec Patroller™ is the AutoVu™ software application installed on an in-vehicle computer. Genetec Patroller™ connects to Security Center and is controlled by the LPR Manager.	<ul style="list-style-type: none"> <li><a href="#">Installing Genetec Patroller™</a></li> </ul> For more information, see the <i>Genetec Patroller™ Administrator Guide</i> .
12	Connect the SharpZ3 system to Genetec Patroller™.	If Genetec Patroller™ does not connect to Security Center, you must offload license plate reads manually using a USB key.	<ul style="list-style-type: none"> <li><a href="#">Configuring where the SharpZ3 sends its ALPR data</a> on page 152</li> </ul>
13	Configure Genetec Patroller™.	There are many tasks that must be performed to configure Genetec Patroller™, such as configuring your offload settings, connecting to Security Center, and so on.	<ul style="list-style-type: none"> <li><a href="#">Configuring Genetec Patroller™</a></li> </ul> For more information, see the <i>Genetec Patroller™ Administrator Guide</i> .
14	(Optional) Install the T2 eTicketBook plugin.	If the T2 eTicketBook will be used with Pay-by-Plate, the eTicketBook plugin needs to be installed on the in-vehicle computer.	<ul style="list-style-type: none"> <li>Contact your T2 representative, they will install eTicketBook for you.</li> </ul>
15	Align the SharpZ3 cameras.	You must align your SharpZ3 cameras using the AutoVu™ Alignment Kit so they can read plates accurately.	<ul style="list-style-type: none"> <li><a href="#">Camera alignment</a> on page 84</li> </ul>
16	Complete the installation.	At the end of the installation you should test the system to ensure that the hardware is functional, and perform a read report to test performance.	<ul style="list-style-type: none"> <li><a href="#">Completing the deployment</a> on page 169</li> </ul>

## About MLPI systems

The Mobile License Plate Inventory (MLPI) solution is recommended for customers wishing to gather an inventory of vehicles in their parking facilities.

The MLPI solution supports lot counts and inventory reconciliation features. It can also compare reads to simple hotlists to notify operators of any match. The MLPI solution does not integrate with third-party ticketing systems and is not compatible with AutoVu™ Pay-by-Plate Sync.

### MLPI enforcement deployment overview

There are many tasks involved in deploying a SharpZ3 system for Mobile License Plate Inventory (MLPI). Use this overview as a reference to guide you through the process.

#### Preparing for the deployment

These are the tasks to perform before you go on site for the deployment. If you cannot complete the tasks on this checklist, contact your AutoVu™ representative.

Step	Task	Description	Where to find more information
1	Fill out the <i>AutoVu™ Deployment Questionnaire</i> .	The questionnaire helps you collect the information required to deploy the system.	<ul style="list-style-type: none"> <li>• <a href="#">About the AutoVu™ deployment questionnaire</a> on page 15</li> </ul>
2	Read the product related release notes.	The release notes contain information about the current releases, as well as any known issues or limitations.	<ul style="list-style-type: none"> <li>• <a href="#">Security Center Release Notes</a></li> <li>• <a href="#">Sharp Release Notes</a></li> <li>• <a href="#">Genetec Patroller™ Release Notes</a></li> </ul>
3	Install Security Center.	Security Center receives reads from Genetec Patroller™ software.	<ul style="list-style-type: none"> <li>• <a href="#">Installing Security Center</a>.</li> </ul> <p>For more information, see the <i>Security Center Installation and Upgrade Guide</i>.</p>
4	Install BeNomad maps.	BeNomad provides the SharpZ3 system with maps and reverse geocoding information.	<ul style="list-style-type: none"> <li>• <a href="#">Installing the BeNomad mapping solution for Security Center</a></li> <li>• <a href="#">Installing BeNomad files on the in-vehicle computer</a></li> <li>• For more information, see the <i>Security Center Administrator Guide</i>.</li> </ul>
5	Configure the LPR Manager role in Security Center.	The LPR Manager is the role that manages and controls the patrol vehicles running Genetec Patroller™ software.	<ul style="list-style-type: none"> <li>• <a href="#">Configuring LPR Manager roles</a></li> </ul> <p>For more information, see the <i>Security Center Administrator Guide</i>.</p>
6	Configure the Archiver role in Security Center.	The Archiver is the role that stores video streams and ALPR images.	<ul style="list-style-type: none"> <li>• <a href="#">Setting up the Archiver role for ALPR</a></li> </ul> <p>For more information, see the <i>Security Center Administrator Guide</i>.</p>



Step	Task	Description	Where to find more information
7	Configure parking facilities.	You must create a parking facility to track the location of vehicles.	<ul style="list-style-type: none"> <li><a href="#">Creating parking facilities</a></li> </ul> For more information, see the <i>Security Center Administrator Guide</i> .
8	(Optional) Configure hotlists.	To use hotlist entities in Security Center, you must create the hotlist, map it to a source text file, and configure it for your enforcement scenario.	<ul style="list-style-type: none"> <li><a href="#">Create hotlists</a></li> </ul> For more information, see the <i>Security Center Administrator Guide</i> .

## On site tasks

These are the tasks to perform while on site. If you can't complete the tasks on this checklist, contact your AutoVu™ representative.

Step	Task	Description	Where to find more information
1	Install expansion modules.	Depending on the deployment type you might need to install one or more expansion modules in the SharpZ3 base unit.	<ul style="list-style-type: none"> <li><a href="#">About SharpZ3 expansion modules</a> on page 45</li> </ul>
2	Install the SharpZ3 base unit in the vehicle.	You can mount the base unit anywhere inside the vehicle that is safe, secure, and has good airflow.	<ul style="list-style-type: none"> <li><a href="#">Base unit installation</a> on page 52</li> </ul>
3	Install peripheral hardware.	In addition to the SharpZ3 base unit and cameras, you must install hardware that is associated with vehicle odometry or with SharpZ3 expansion modules.	<ul style="list-style-type: none"> <li><a href="#">Navigation hardware options</a> <ul style="list-style-type: none"> <li><a href="#">Installing the SharpZ3 satellite navigation hardware</a></li> <li><a href="#">Installing the GlobalSat GPS driver</a></li> </ul> </li> <li><a href="#">Installing the odometry sensor</a></li> <li><a href="#">Installing the cellular antenna</a></li> <li><a href="#">Installing the car camera switch</a></li> </ul>
4	Install the SharpZ3 cameras on the vehicle.	Depending on the hardware ordered, systems can support either two or four SharpZ3 cameras.	<ul style="list-style-type: none"> <li><a href="#">About camera mounting</a> on page 63</li> </ul>
5	Install and configure the in-vehicle computer.	The in-vehicle computer must be powered through the base unit's auxiliary 8A Max relay.	<ul style="list-style-type: none"> <li><a href="#">ToughPad computer installation</a> on page 109</li> </ul>

Step	Task	Description	Where to find more information
6	Install a certificate to secure the Sharp Portal.	SharpZ3 cameras must communicate using TLS encryption (HTTPS) using either the certificate that is auto-generated on the SharpZ3, a new self-signed certificate, or a signed certificate from your own public key infrastructure (PKI) or from a Certificate Authority such as VeriSign.	<ul style="list-style-type: none"> <li>• <a href="#">Installing the SharpZ3 auto-generated certificate</a> on page 136</li> <li>• <a href="#">Installing a self-signed certificate</a> on page 138</li> <li>• <a href="#">Installing a signed certificate</a> on page 140</li> </ul>
7	Configure the positions of the SharpZ3 cameras.	Based on the location of the patrol vehicle and the position of the SharpZ3 cameras, the system can calculate the location of the target vehicle.	<ul style="list-style-type: none"> <li>• <a href="#">Configuring SharpZ3 position and location</a> on page 145</li> </ul>
8	Configure SharpZ3 analytics.	You can configure which plates the SharpZ3 will read, and whether the system should attempt to read the plate origin, vehicle make, vehicle type and color, and so on.	<ul style="list-style-type: none"> <li>• <a href="#">Configuring SharpZ3 analytics</a> on page 150</li> </ul>
9	Install Genetec Patroller™.	Genetec Patroller™ is the AutoVu™ software application installed on an in-vehicle computer. Genetec Patroller™ connects to Security Center and is controlled by the LPR Manager.	<ul style="list-style-type: none"> <li>• <a href="#">Installing Genetec Patroller™</a></li> </ul> <p>For more information, see the <i>Genetec Patroller™ Administrator Guide</i>.</p>
10	Connect the SharpZ3 system to Genetec Patroller™.	If Genetec Patroller™ does not connect to Security Center, you must offload license plate reads manually using a USB key.	<ul style="list-style-type: none"> <li>• <a href="#">Configuring where the SharpZ3 sends its ALPR data</a> on page 152</li> </ul>
11	Configure Genetec Patroller™.	There are many tasks that must be performed to configure Genetec Patroller™, such as configuring your offload settings, connecting to Security Center, and so on.	<ul style="list-style-type: none"> <li>• <a href="#">Configuring Genetec Patroller™</a></li> </ul> <p>For more information, see the <i>Genetec Patroller™ Administrator Guide</i>.</p>
12	Align the SharpZ3 cameras.	You must align your SharpZ3 cameras using the AutoVu™ Alignment Kit so they can read plates accurately.	<ul style="list-style-type: none"> <li>• <a href="#">Camera alignment</a> on page 84</li> </ul>
13	Complete the installation.	At the end of the installation you should test the system to ensure that the hardware is functional, and perform a read report to test performance.	<ul style="list-style-type: none"> <li>• <a href="#">Completing the deployment</a> on page 169</li> </ul>

# About SharpZ3 hardware installation

This section includes the following topics:

- ["Hardware components for a SharpZ3 installation"](#) on page 37
- ["Required tools and parts for a SharpZ3 installation"](#) on page 39
- ["Wire ferrules for SharpZ3 installations"](#) on page 41
- ["Conductor arrangements for SharpZ3 cameras"](#) on page 42

# Hardware components for a SharpZ3 installation

An AutoVu™ SharpZ3 system is installed on law enforcement or parking patrol vehicles. The system typically includes a SharpZ3 base unit, SharpZ3 ALPR cameras, and peripheral devices.

Before installing a SharpZ3 system, familiarize yourself with the hardware components of the system:

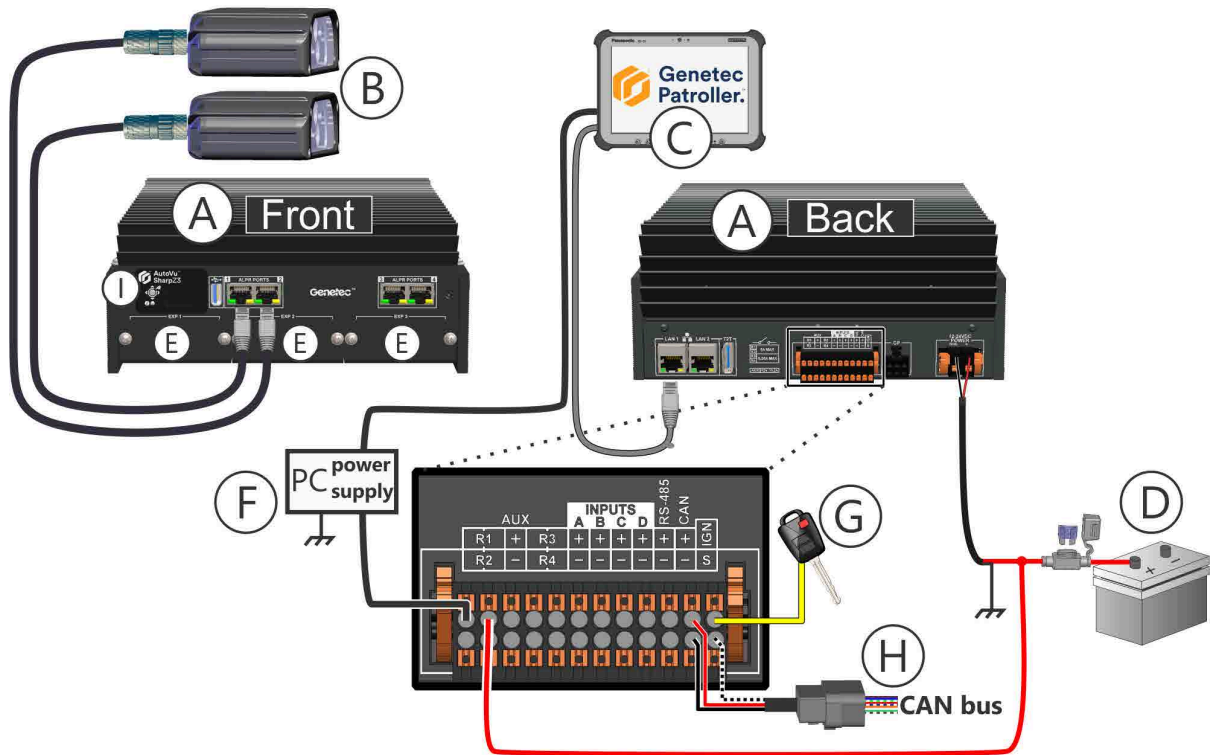

Component	What you should know
<b>A Base unit</b>	The base unit is the main processing component of the SharpZ3 system and is generally installed in the trunk of the patrol vehicle. For more information, see <a href="#">Base unit installation</a> on page 52.
<b>B SharpZ3 cameras</b>	SharpZ3 cameras can be installed on the patrol vehicle using a hardmount or a magnetic mount (magmount). Hardware is also available for mounting the cameras on the vehicle's lightbar. For more information, see <a href="#">About camera mounting</a> on page 63.
<b>C In-vehicle computer</b>	The in-vehicle computer displays license plate reads and hits to the driver of the vehicle using Genetec Patroller™ software. SharpZ3 systems generally include a Panasonic ToughPad. For more information, see <a href="#">ToughPad computer installation</a> on page 109.
<b>D Power cable with inline fuse</b>	The base unit is connected to vehicle's battery with a fuse installed as close to the battery as possible. For more information, see <a href="#">Connecting power to the base unit</a> on page 56.

Component	What you should know
<b>E</b> <b>Expansion slots</b>	To add capabilities to the system, you can install up to three expansion modules in the SharpZ3 base unit. For more information, see <a href="#">About SharpZ3 expansion modules</a> on page 45.
<b>F</b> <b>In-vehicle computer power supply</b>	Power is supplied to the Panasonic ToughPad using the base unit's 8A relay. For more information, see <a href="#">About powering the in-vehicle computer</a> on page 118.
<b>G</b> <b>Vehicle ignition</b>	To power the SharpZ3 system, you must connect the base unit to the vehicle's power and ignition signal. When properly connected, the system is supplied with the vehicle's 12 VDC power when the ignition is on. For more information, see <a href="#">Connecting the ignition signal</a> on page 55.
<b>H</b> <b>CAN bus</b>	Future use.
<b>I</b> <b>Base unit control interface</b>	Future use.

# Required tools and parts for a SharpZ3 installation

---

Before installing SharpZ3 hardware, make sure that you have the tools and parts required to successfully complete the installation process.

## Tools

There are a number of additional required tools and parts that are not included with the AutoVu™ installation kit.

- **AutoVu Alignment Kit:** Includes several tools that are recommended for AutoVu™ installations.
- **Electric or battery powered drill and drill bits:** Required when running cables through the vehicle roof or body panels.
- **Multimeter:** Required for measuring electrical current in the OEM fuse box.
- **Digital level:** Used for measuring the camera tilt.
- **Depth-controlled cable jacket stripper:** Recommended for stripping the cable jacket to avoid damage to the internal conductors. The Cyclops stripping tool is included with the AutoVu™ Alignment Kit.
- **Wire stripper:** Required for stripping wire insulation.
- **RJ45 crimp tool:** Use a professional quality tool for proper crimping. The EZ-RJPRO® HD Crimp Tool is included with the AutoVu™ Alignment Kit.
- **Panel removal tool:** Use the correct panel removal tools to ensure that the vehicle panels are not damaged during the installation.

**NOTE:** You might also need a Philips, Torx, or flat blade screwdriver.

- **2.5 mm flat-tip screwdriver:** Used for pushing in tension clamps and securing screws.
- **Hex key wrenches:** Required when mounting the cameras on the patrol vehicle.
- **Torque wrench:** Required to ensure connections are not over-tightened or under-tightened.
- **Wire ferrule crimping tool:** Ferrules are included for all wire connections and are recommended, but not mandatory. A crimping tool is included with the AutoVu™ Alignment Kit.
- **Phillips screwdriver:** Required when installing hardware such as expansion modules, and wire racks.
- **Adjustable wrench:** Required when mounting the base unit in the patrol vehicle.
- **Center punch:** Used to mark drilling locations.
- **Hole saw or stepping drill bit:** For cable penetrations, you can use a stepping drill bit or you can use a fine-toothed hole saw designed for vehicle body panels which is depth-regulated and includes a pilot drill bit.
- **Grease pencil:** Used to mark support locations on the roof of the vehicle.
- **Roll of tape:** Required when installing the odometry sensor and when mounting cameras.

## Parts

- **Wires (stranded):**
  - **Base unit 12V power:** 14 AWG (red) and 14 AWG (black)
  - **I/O connector:** 22 to 18 AWG
  - **Ignition signal:** 22 to 18 AWG (yellow)
  - **Navigation expansion module:**
    - **Reverse signal (REV):** 24 to 18 AWG
    - **Chassis ground (CGND):** 18 AWG (black)
    - **VSS (ODO +/-):** 24 to 20 AWG shielded, twisted pair
    - **Odometry sensor (ODO +/-):** 22 to 20 AWG jumper wire
- **20A ATO/ATC in-line fuse:** Required at the source of the vehicle's 12-24V system tapping point.
- **0.5A fuse:** In-line or in the OEM fuse box using a tap fuse adapter.

- **Ring terminal:** A ring terminal with incorporated internal locking teeth is required at the chassis grounding screw location.
- **Heat-shrink tubing:** Required for the protection of soldered wire connections.
- **Convolute wire loom:** Required to protect cables from potential damage from heat or abrasion.
- **Cable glands:** Required when sealing wire holes drilled in the vehicle's roof.

**NOTE:** Cable glands are required for all cable penetrations. Ensure that you have the appropriate glands in installing a cellular antenna or satellite navigation antenna.

- **Butyl tape and isopropyl alcohol:** Required for sealing any cable penetrations that do not use a cable gland.
- **Base unit mounting screws:** Use appropriate screws to attach the bracket to the vehicle: ¼"-20 or M6. The screws must be long enough to secure the hardware, but short enough not to damage any vehicle components under the mounting location.

## Wire ferrules for SharpZ3 installations

For a more secure connection when making wire connections to the SharpZ3 base unit, use the ferrule crimping tool that is included with the AutoVu™ Alignment Kit to crimp the appropriate ferrule to the end of each stripped wire.

**IMPORTANT:** Use the ferrules provided with the SharpZ3 hardware. The SharpZ3 requires longer ferrules than those used with SharpX systems.

The following table shows the appropriate ferrules for each wire gauge:

Wire AWG	Ferrule color
14	Blue
18	Red
20	Grey
22	White
24	Violet

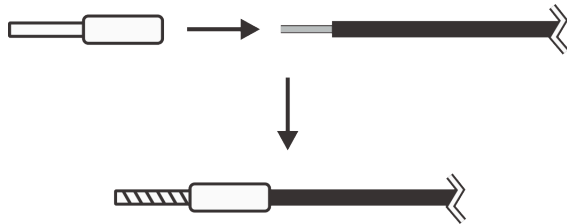



## Conductor arrangements for SharpZ3 cameras

The following table lists the conductor arrangements for SharpZ3 cameras

You must terminate the SharpZ3 camera cables according to the EIA-T568B conductor arrangement.

Pin #	EIA-T568B
1	White/Orange
2	Orange
3	White/Green
4	Blue
5	White/Blue
6	Green
7	White/Brown
8	Brown



# Module installation

This section includes the following topics:

- ["Installing the ALPR module"](#) on page 44
- ["About SharpZ3 expansion modules"](#) on page 45
- ["Installing expansion modules"](#) on page 46
- ["Navigation expansion module connections"](#) on page 48
- ["Aux PoE expansion module connections"](#) on page 50

# Installing the ALPR module

---

To connect SharpZ3 cameras to the base unit, you must install an ALPR module. ALPR modules are available for two-camera or four-camera systems.

## Before you begin

To complete these steps, you need the following:

- Phillips #1 screwdriver

### To install the ALPR module:

- 1 Place the ALPR module on the base unit and slide it into place.



- 2 Firmly press the module to ensure that the connection at the back of the module is solid.

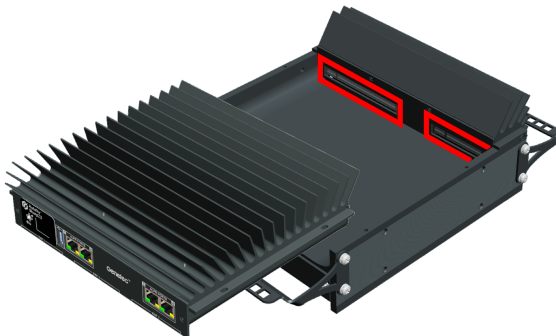

- 3 Secure the ALPR module using the provided Phillips screws.

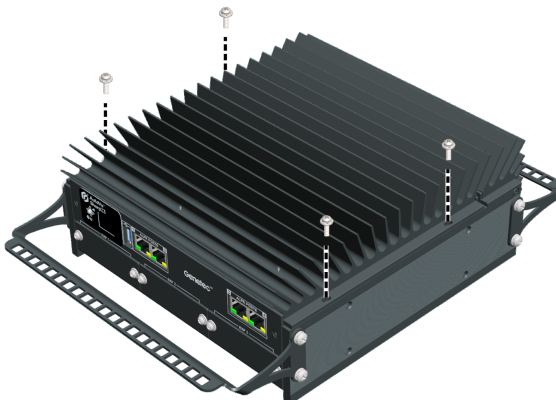

## About SharpZ3 expansion modules

To add functionality to the SharpZ3 system, you can install up to three expansion modules in the base unit.

Expansion modules give the system the flexibility to be configured for the requirements of different applications. For example, you can configure your parking enforcement and law enforcement patrol vehicles with different camera configurations or add precise positioning to the system.

**TIP:** You can install any SharpZ3 expansion module in any base unit expansion module slot, however certain slots are preconfigured for certain modules. Installing a module in the correct slots can eliminate certain manual configuration steps. For more information, see [Default expansion module configurations](#).

The following SharpZ3 expansion modules are available:

- **Navigation expansion module:** Adds precise positioning to the SharpZ3 system.

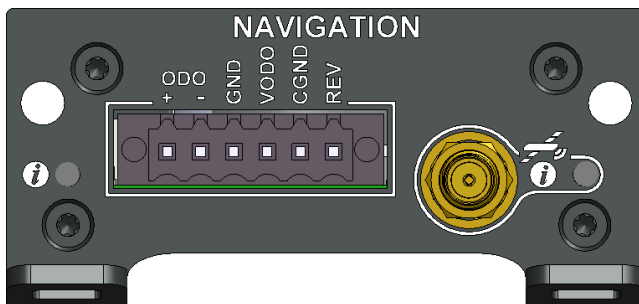

- **AUX PoE expansion module:** Connect wheel-imaging cameras or other PoE devices in the vehicle.

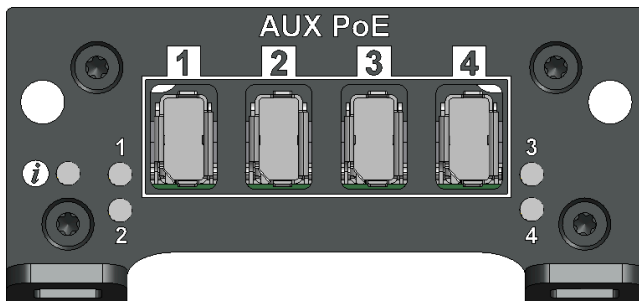

### Related Topics

[Aux PoE expansion module connections](#) on page 50

[Navigation expansion module connections](#) on page 48

# Installing expansion modules

The SharpZ3 expansion modules add additional capabilities to the SharpZ3 system. You can install up to three expansion modules in the SharpZ3 base unit.

## Before you begin

To complete these steps, you need the following:

- Phillips #1 screwdriver

## What you should know

- The base unit has three expansion slots. Each slot is covered by an expansion slot protector until a module is installed.
- It is easier to install the expansion modules before the base unit is mounted in the patrol vehicle.

### To install an expansion module:

- 1 Remove the protector from an available expansion module slot:
  - a) Remove the two Phillips screws.
  - b) Slide out the protector.



- 2 Install the expansion module:
  - a) Slide the module into the slot.
  - b) Firmly press the module to ensure that the connection at the back of the module is solid.
  - c) Secure the module in the slot using the two screws that you removed from the slot protector.

**TIP:** While tightening the screws, gently lift up the module. This aligns the tops of the modules and provides slightly more space under the base unit.



**Related Topics**

[Navigation expansion module connections](#) on page 48

[Aux PoE expansion module connections](#) on page 50

# Navigation expansion module connections

With the navigation expansion module, the SharpZ3 system can add precise location information to license plate reads and can ensure that the patrol vehicle is accurately displayed on maps in Genetec Patroller™.

To provide the wheel tick information required for precise positioning, you can connect the base unit to the vehicle's VSS signal, or you can install the odometry sensor.

## VSS connections

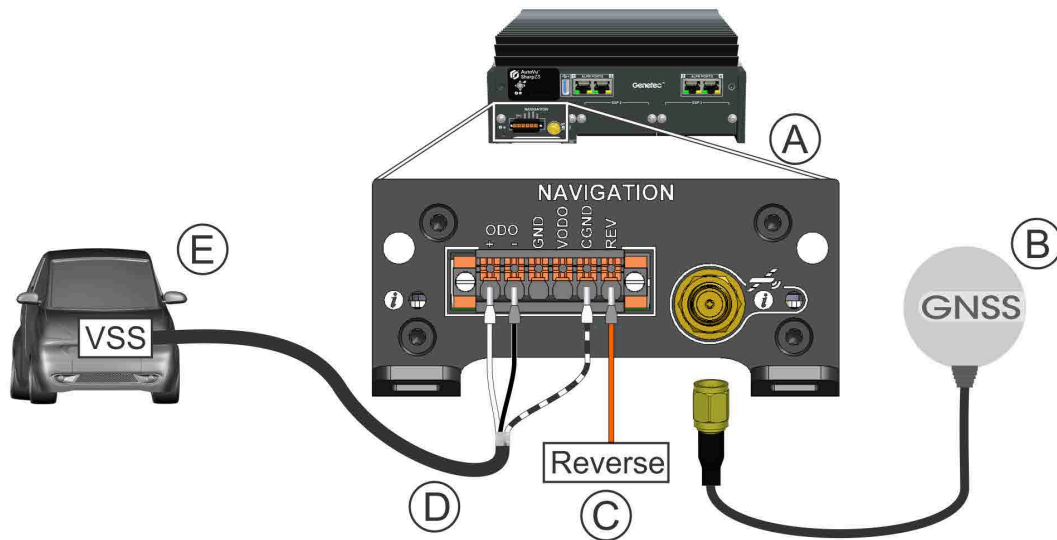

## Odometry sensor connections

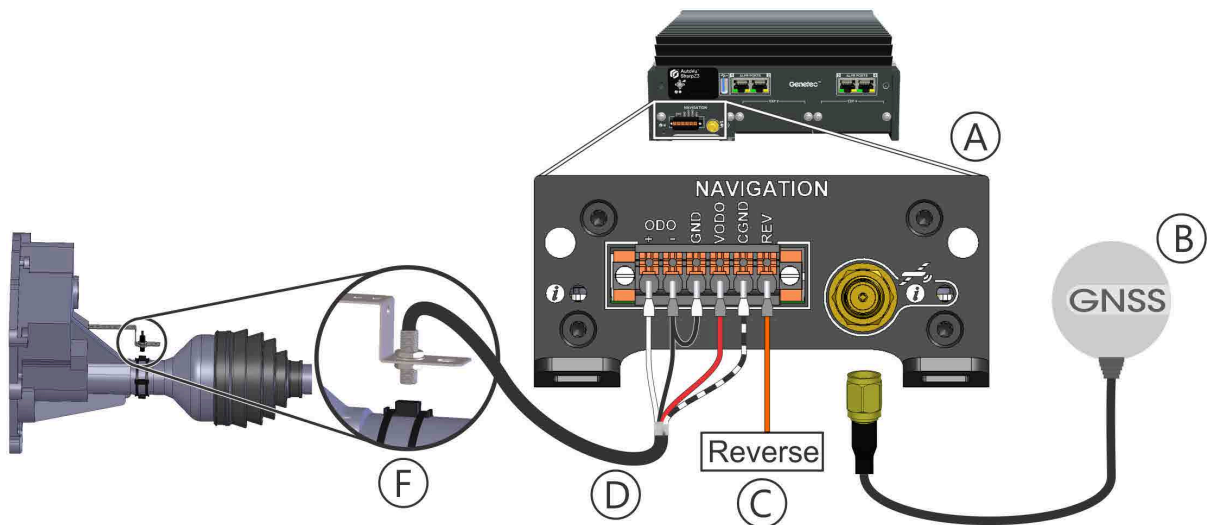

Component	Description
A	Navigation expansion module The navigation expansion module adds precise positioning to the SharpZ3 system.

	Component	Description
<b>B</b>	Satellite navigation antenna	<p>The GNSS satellite navigation antenna is connected to the base unit and works with the odometry inputs to provide precise georeferencing for the vehicles associated with the plate reads. For more information on which satellite navigation hardware to install, see <a href="#">Satellite navigation hardware options</a> on page 90.</p> <p><b>NOTE:</b> Connecting the satellite navigation antenna to the navigation expansion module provides more accurate location information than connecting an antenna to the in-vehicle computer.</p>
<b>C</b>	Reverse signal	<p>The SharpZ3 system is usually connected to the vehicle's reverse signal by tapping the reverse lights.</p>
<b>D</b>	VSS or odometry sensor cable connection	<p>Connect the hardware to the base unit as shown in the diagram.</p> <p><b>NOTE:</b> The wire that connects to the CGND pin is the drain wire from the sensor cable.</p>
<b>E</b>	VSS signal	<p>You can tap the VSS signal from the vehicle's power-train control module (PCM). For more information, see the vehicle's electrical schematics documentation.</p> <p><b>NOTE:</b> Some newer vehicles and electric vehicles do not include a VSS or OSS.</p>
<b>F</b>	Odometry sensor	<p>If the VSS signal from the vehicle is unavailable, you can install an odometry sensor. In general, a VSS provides more ticks per wheel rotation, resulting in more accurate odometry. For more information on the odometry sensor, see <a href="#">Installing the odometry sensor</a> on page 93.</p>

---

### Related Topics

[Installing the odometry sensor](#) on page 93



## Aux PoE expansion module connections

The Aux PoE expansion module provides four Power over Ethernet (PoE) ports to the SharpZ3 base unit. The module provides power for wheel-imaging cameras, additional context cameras, or other PoE devices in the patrol vehicle.

### Connections for PoE devices

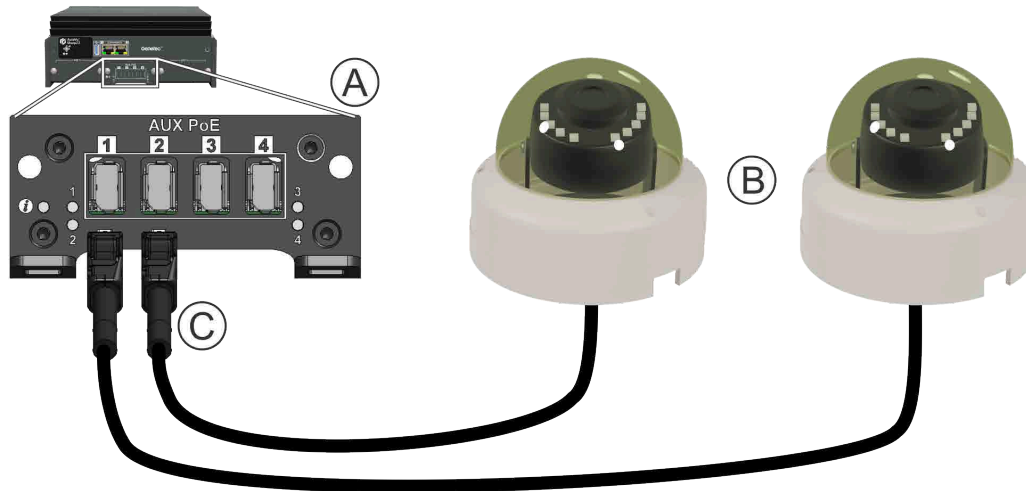

	Component	Description
A	Aux PoE expansion module	The Aux PoE expansion module lets you add up to four PoE devices to the system.
B	PoE devices	You can associate each SharpZ3 camera with its own PoE camera, or you can associate the same PoE camera with multiple SharpZ3 cameras.
C	IX industrial connector	The four Aux PoE expansion module ports are compatible with ix industrial connectors.

# Base unit installation

This section includes the following topics:

- ["Base unit installation"](#) on page 52

# Base unit installation

The base unit is the processing component of the SharpZ3 system and is typically installed in the trunk of the patrol vehicle. The best mounting location depends on the type of vehicle and the location of any other hardware installed in the vehicle.

You can mount the base unit anywhere inside the vehicle that is safe, secure, and has good airflow. When planning an installation, you must decide the best location and orientation for the base unit. Vertical and horizontal mounting brackets are included with the base unit kit.

The following example shows base units mounted vertically and horizontally:



## Best practices for mounting the base unit

When you mount a base unit in a patrol vehicle, you must consider space restrictions, protection of the unit from impact, and other factors. You must also have the correct mounting hardware for installations on carpet, metal, or plywood.

Consider the following best practices when planning the base unit installation.

### General recommendations

- **WARNING:** The the heat dissipation fins on the ALPR module might have sharp edges. Take care when installing the hardware. Ensure that the base unit is not installed within reach of passengers in the vehicle.
- Install the base unit in an area with adequate ventilation around the heat dissipation fins.
- Install the base unit in an area protected from water or dust infiltration.

- If you mount the trunk unit vertically, orient the heat dissipation fins vertically.

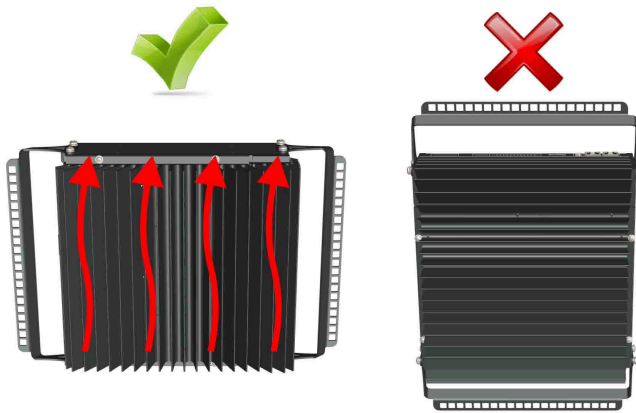

- Make sure that there is nothing vital (for example, break lines or the fuel tank) that could be damaged when screwing the mounting bracket to the vehicle.
- Select an appropriate mounting surface. In this example, the back of the seat is reinforced with fabric-covered plywood.

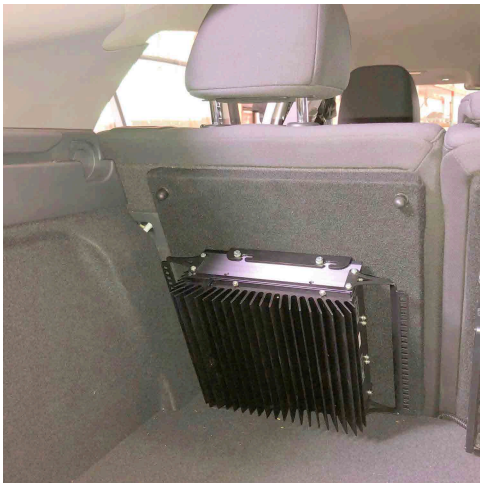

- Use appropriate screws to attach the bracket to the vehicle: ¼"-20 or M6. The screws must be long enough to secure the hardware, but short enough not to damage any vehicle components under the mounting location.
- Cable racks are included for the front and back of the base unit. To protect the cable connections from damage, install the cable racks and secure all cables with tie wraps.

#### Hardware orientation

- To ensure adequate heat dissipation, do not mount the base unit upside down.

#### Horizontal mount

- The horizontal mounting brackets are generally installed with the mounting flanges pointing outward. If required, you can install the brackets with the flanges pointing inward. If you are installing the bracket

this way, keep in mind that you must install the brackets in the vehicle before mounting the base unit. This is because the mounting holes are not accessible after the base unit is connected to the brackets.



- To install the brackets with the flanges pointing inward, use the paper template that is provided with the hardware to accurately mark the positions of the mounting holes.

### Vertical mount

- When selecting an installation location, leave enough space to easily access the mounting screws with a wrench.
- Install the vertical bracket before connecting the base unit.
- To mount the base unit vertically, install the bracket base (A) in the vehicle using ¼"-20 or M6 screws. Connect the vertical mounting bracket (B) to the base unit (C), then mount the assembly to base bracket using the provided locknuts.



### Related Topics

[About the trunk unit cable racks](#) on page 60

## Connecting the ignition signal

To power the base unit, you must connect it to the vehicle's power and ignition signal. When properly connected, the base unit is supplied with the vehicle's 12 VDC power when the ignition is on.

### What you should know

You can obtain the ignition signal from the fuse box using a fuse tap adapter. Using this adapter, you can tap into the fused circuit and give a fused connection to the base unit.

**WARNING:** Simply shutting off the main power to the base unit can corrupt the base unit and make the system inoperable. To turn on and turn off the base unit safely, the system requires an ignition signal.

**IMPORTANT:** These instructions do not replace your vehicle's owner manual. If you are unsure about your vehicle's electrical wiring, see your owner's manual before continuing.

#### To connect the vehicle's ignition signal to the base unit:

- 1 Use a multimeter to identify the ignition signal from the fuse box:  
It should be a circuit that supplies 12V when the key is switched to the RUN position, and is off when the key is in the OFF position.
  - a) With the key in the OFF position, use either a circuit tester or a volt meter to identify the fuses that are 10A or less and that do not have power.
 

**WARNING:** Do not tap fuses that are related to the automatic braking system (ABS) or the airbags.
  - b) Turn the key to the RUN position and identify which of those fuses now have power.
  - c) When you have identified a suitable fuse, cycle the power to ensure that the power is on when the key is in the RUN position and off when the key is in the OFF position.
- 2 Install the tap fuse adapter:
  - a) Remove the ignition signal fuse from the fuse box.
  - b) Insert the fuse into the fuse tap adapter.
  - c) Install a 0.5A fuse in the added circuit holder.
  - d) Install the fuse tap adapter into the fuse box.

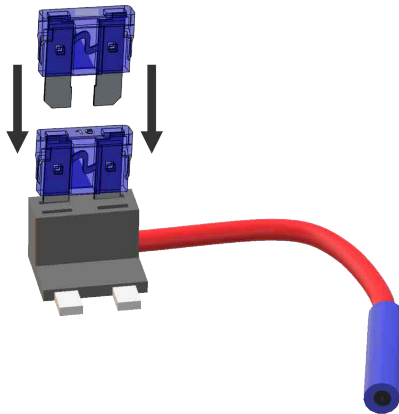

- 3 Connect the wire from the base unit's IGN pole to the fuse tap adapter.
 

**IMPORTANT:** For a more secure connection, crimp a ferrule to the tip of each stripped wire. Use the [appropriate ferrule for the wire gauge](#).

**NOTE:** The IGN pole draws negligible current. It is simply used to sense the ignition signal.
- 4 Label the connections for future service.

## Connecting power to the base unit

To power the base unit, you must connect it to the vehicle's power. The base unit requires a constant power source of 12 VDC protected with a 20A fuse.

### Before you begin

To complete these steps, you need the following:

- **Stranded copper wire:** 14 AWG (red) and 14 AWG (black) for 12V power on the base unit.
- **Heat-shrink tubing:** Required for the protection of soldered wire connections.
- **Ring terminal:** A ring terminal with incorporated internal locking teeth is required at the chassis grounding screw location.
- **20A ATO/ATC in-line fuse:** Required at the source of the vehicle's 12-24V system tapping point.

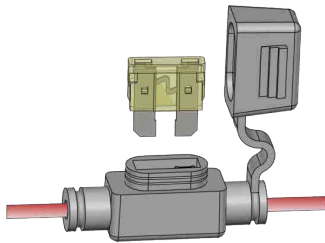

- **Convolute wire loom:** Required to protect cables from potential damage from heat or abrasion.

#### IMPORTANT:

- These instructions do not replace your vehicle's owner manual. If you are unsure about your vehicle's electrical wiring, see your owner's manual before continuing.
- Solder your connections and protect them with heat shrink tubing.

### What you should know

You can use the base unit to switch power for auxiliary devices, such as [power for the tablet computer](#) or a modem.

**WARNING:** Simply shutting off the main power to the base unit can corrupt the base unit and make the system inoperable. To turn on and turn off the base unit safely, the system requires an [ignition signal](#).

#### To connect the base unit to the vehicle's 12V power source:

- 1 Connect a wire from the base unit's positive (+) terminal, through the 20A in-line fuse, to the vehicle's 12V power source (permanent +12V).

#### NOTE:

- Install the fuse at the source of your vehicle's 12V system tapping point. The base unit is already protected internally by an electronic circuit breaker.
  - If you connect the primary power lead from the battery, it must be fused within 2 inches of the battery.
- 2 Label the primary wire at the fuse to help identify the circuit for future service.
  - 3 Run the wire to the base unit location.

**IMPORTANT:** Protect the wire with a convolute wire loom and secure the loom from potential heat damage or abrasion.

- Connect the wire from your base unit's GND pole to your vehicle's chassis for grounding.

**NOTE:**

- Ensure that the ground connection is clean and secure and that there is no paint impeding the connection.
  - Do not make the chassis ground connections at a weld point.
  - A ring terminal with incorporated internal locking teeth is required at the chassis grounding screw location. For a reliable connection, select ring terminals that are compatible with the size of the stud, screw, or bolt that will be used to attach them to the vehicle.
- Ensure that the power connector is securely installed in the base unit with the connector clamps engaged.

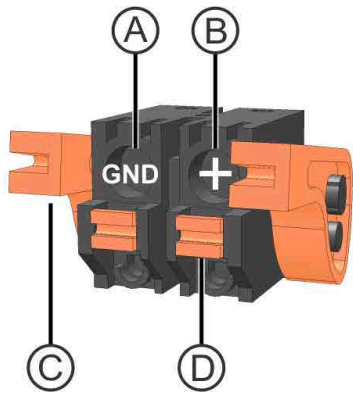

Component	
A	Negative/return/GND. Use 14 AWG (black)
B	Permanent 12V (+). Use 14 AWG (red)
C	Connector clamp
D	Wire tension clamps

- Strip 10 mm ( $\frac{3}{8}$  in.) of insulation from the stranded copper wires.

**IMPORTANT:** For a more secure connection, crimp a ferrule to the tip of each stripped wire. Use the [appropriate ferrule for the wire gauge](#).

**WARNING:** Do not lengthen any power or signal wires. If the wire you are installing is too short, replace with a new longer wire. Splices are a point of possible failure which can cause the system to malfunction.

- Insert the red wire into the positive (+) connector pole.
- Insert the black wire into the ground (GND) connector pole.

## Power management in a SharpZ3 system

The SharpZ3 system includes an auto shutdown feature to protect the vehicle battery and a cranking event protection feature which prevents a reboot due to a voltage dip caused by engine startup.

### Auto shutdown

If the vehicle engine is off and the SharpZ3 system is running solely on vehicle battery power, the system shuts down after a 60 second delay (configurable) if battery voltage falls below 10.3 V at the base unit power connector. Note that there is an approximate 5 to 7 V drop between the battery and the base unit power connector. For more information, see [Configuring battery monitoring](#) on page 133.



After auto shutdown, the SharpZ3 system restarts when it detects a voltage greater than 12 V. When the vehicle engine is running again, the voltage typically increases to >12.6 V, which allows the SharpZ3 system to power up again.

**NOTE:** You can configure the startup voltage (default 12 V) in the Sharp Portal.

## Cranking event protection

Many law enforcement vehicles include external timers that maintain power to the equipment such as radios even when the engine is off. If the SharpZ3 system is being powered with an external timer, and the engine is then turned on, the resulting dip in voltage does not cause the SharpZ3 system to restart. The system can withstand a temporary voltage dip down to 7 V.

## Installing the base unit cooler pack

If you install a SharpZ3 system with a four-camera ALPR module in extreme environments where the ambient temperature in the patrol vehicle trunk exceeds the unit's maximum temperature rating, you must install the SharpZ3 cooler pack on the base unit.

### What you should know

- When installing the base unit, leave at least 5cm (2 in.) of space above the unit to ensure proper air circulation.
- To confirm if the base unit fan is required for your installation, contact your AutoVu™ representative.
- You can mount the cooler pack on either side of the base unit.



SharpZ3 base unit maximum temperature rating:

Configuration	ALPR module	Maximum ambient air temperature
Without cooler pack	Two-camera ALPR module	65°C (150°F)
	Four-camera ALPR module	50°C (122°F)
With cooler pack	Two-camera ALPR module	Cooler pack not required
	Four-camera ALPR module	65°C (150°F)

**To install the SharpZ3 cooler pack on the base unit:**

- 1 Align the cooler pack clips with the correct heat sink fins.

**TIP:** The point on the cooler pack body should align with the gap between the base unit body and the ALPR module.

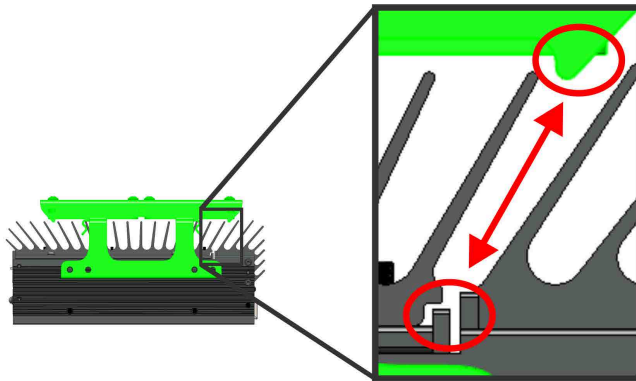

- 2 Press down to clip the cooler pack into place.

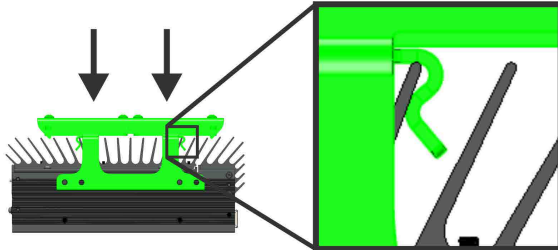

- 3 Secure the bracket using the provided hex head screws and washers.



- 4 Connect the cooler pack cable to the **CP** plug on the back of the base unit.

- 5 Secure the cable to the cooler pack frame and to the wire rack using cable ties.

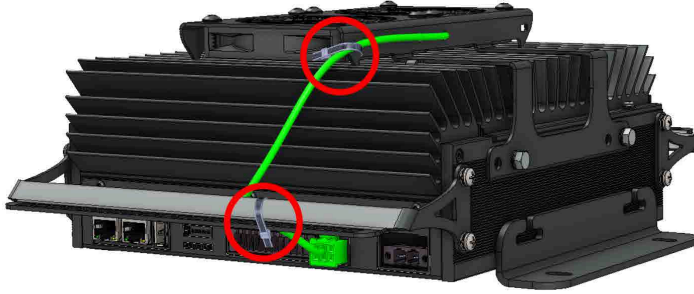

## About the trunk unit cable racks

To protect the SharpZ3 cable connections from damage, cable racks are included with the base unit.

Note the following when installing the base unit in the patrol vehicle:

- If you remove the cable racks during the base unit installation, you must reattach them before you finish the installation.
- Cable racks are included for the front and back of the base unit.
- The cable racks are not symmetrical. In tight installation locations, you can flip the cable racks to provide a better fit.

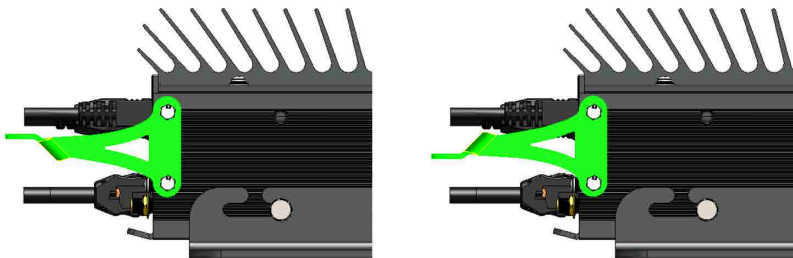

- To protect cables from impact and abrasion, do not attach cables to the edge of the cable rack. Instead, loop cable ties through the inside of the cable rack.

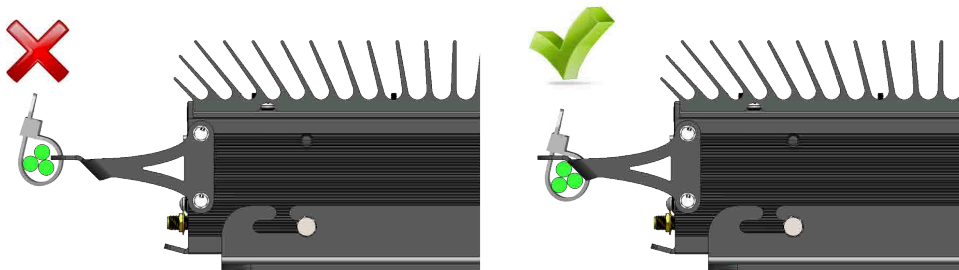

- For a cleaner installation, secure camera cables to the top of the cable rack and secure expansion module cables to the bottom of the cable rack.

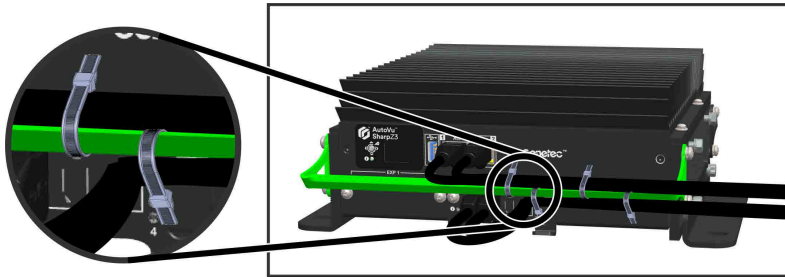

**Related Topics**

[Best practices for mounting the base unit](#) on page 52

# Camera installation

This section includes the following topics:

- ["About camera mounting"](#) on page 63
- ["Hardmount camera installation"](#) on page 64
- ["Installing the SharpZ3 camera using the magmount"](#) on page 69
- ["Lightbar camera installation"](#) on page 71
- ["Drilling a camera cable hole"](#) on page 75
- ["SharpZ3 cabling recommendations"](#) on page 76
- ["Camera cable connection"](#) on page 77
- ["Sealing cable holes in the patrol vehicle "](#) on page 83
- ["Camera alignment"](#) on page 84

## About camera mounting

---

SharpZ3 cameras can be attached to the roof of the patrol vehicle using the Genetec™ universal mounting bracket and pan/tilt mount in conjunction with either the Genetec™ hardmount or magmount.

**IMPORTANT:**

- The warranty is void if you open or drill holes in the AutoVu™ equipment, if you add decals and other adhesive materials, or if you paint SharpZ3 cameras.
- To prevent damage to the cameras and cables, do not bring the patrol vehicle through a contact car wash that uses brushes to scrub the vehicle. Use only non-contact car washes that use water jets.

The following image shows the SharpZ3 mounting configurations:

**Hardmount:**

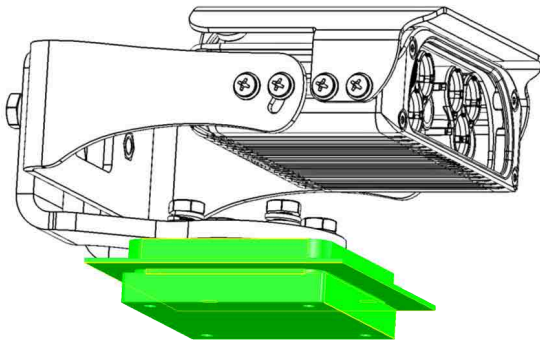

**Magmount:**

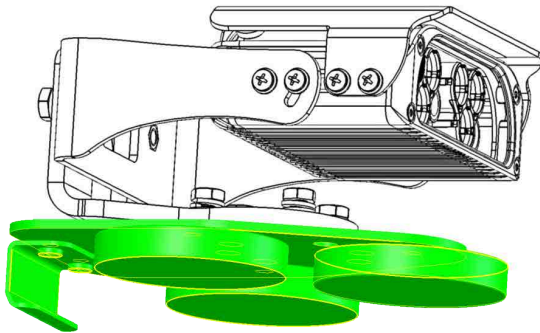

**Lightbar:**

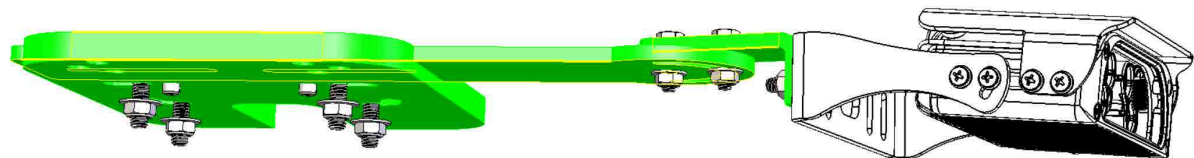

# Hardmount camera installation

---

For permanent installations, SharpZ3 cameras can be attached to the roof of the vehicle using the SharpZ3 universal mounting bracket and pan/tilt mount in conjunction with the Genetec™ hardmount.

## Preparing the vehicle for a hardmounted camera installation

Before installing SharpZ3 camera units on the roof of the patrol vehicle, you must perform some pre-installation steps to prepare the vehicle.

### What you should know

- To complete these steps, you need the following:
  - **Panel removal tool:** Use the correct panel removal tools to ensure that the vehicle panels are not damaged during the installation.
    - NOTE:** You might also need a Philips, Torx, or flat blade screwdriver.
  - **Grease pencil:** Used to mark support locations on the roof of the vehicle.
  - **Center punch:** Used to mark drilling locations.
  - **Electric or battery powered drill and drill bits:** Required when running cables through the vehicle roof or body panels.
- The camera mounting base has four parts: the threaded base block, two rubber gaskets, and the upper mounting block. The upper and lower mounting blocks are installed above and below the roof with the rubber gasket in between to prevent water leaks and reduce vibration.

#### IMPORTANT:

- Before drilling holes in any part of the vehicle body always check for hidden electrical wires or fuel lines.
- Cameras are usually mounted near the tops of the “A pillars” or on the top corners of the windshield. However, you must be careful to avoid drilling through any support bracing that supports the roof.
- Ensure that the roof is stable enough not to vibrate when the camera is installed. If the roof is not stable, install support brackets.
- To seal camera cable holes drilled into the roof of the vehicle, use weatherproof cable glands or weatherproof, non-corrosive sealant such as butyl tape.

**WARNING:** Do not run more than one cable through a cable gland.

#### To prepare the vehicle for a hardmounted camera installation:

- 1 Disconnect the negative (typically black) cable from the vehicle's battery. This is important for your safety and to prevent accidental deployment of the airbags.
- 2 Lower the vehicle headliner to gain access to the underside of the roof. Depending on the vehicle, you might also need to remove trim panels, sun visors, handles, and door gaskets to access the mounting location.

#### NOTE:

- You do not need to completely remove the headliner, but you must gain access to the underside of the mounting location and to the area and locations where you will route the camera cables.
- 3 Identify any supports, braces, airbags, or wiring that might interfere with hardware installation and mark their locations on the top of the vehicle roof.

As it is difficult to know what is directly under the mounting location, we suggest using the "tapping method" to identify obstructions. With one hand on the roof, and your other hand on the under-side of the roof, tap the roof and feel for a solid tap on the under-side. Using this method, you will be able to find any obstructions and mark their location on the roof using a grease pencil.

- Place the upper mounting blocks on the vehicle roof where you intend to install the cameras.

**NOTE:** To reduce the chance of the vehicle roof being visible in the license plate images, select locations that are as close as possible to the corners of the roof.

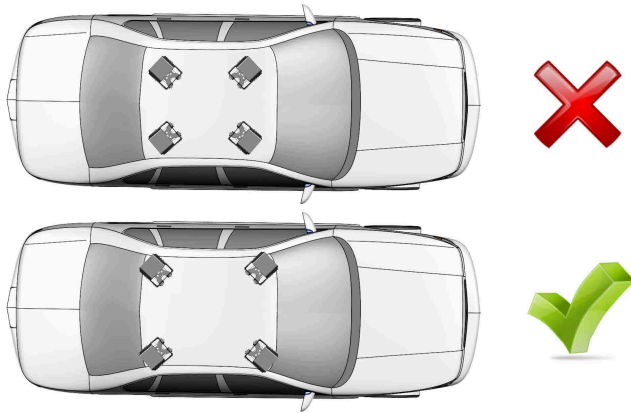

- Measure approximately 15 cm (6 in.) back from the corner of the upper mounting block and make a mark for the camera cable hole. Use the tapping method to verify that there are no roof supports that will interfere with the location.
- Using a center punch, mark the mounting holes (B) in the upper mounting block (A).

**WARNING:** Do not drill the holes (C) that secure the camera to the mount.

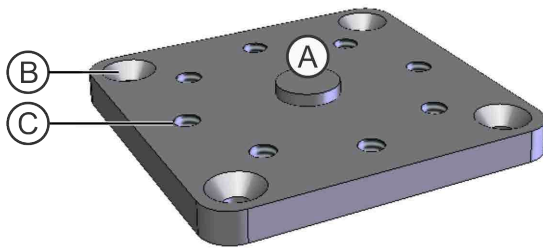

- Drill the mounting holes (B) using a 3.18 cm (1/8 in.) drill bit.

**NOTE:** Although the final hole size is 6.35 cm (1/4 in.), it is recommended that you drill with a smaller drill bit – for example a 1/8 in. bit first. Drilling with a smaller bit allows you to make sure that the placement of the lower block is not impacted by the roof bracing. If you must adjust the mounting position, the small hole can be easily sealed.

- Using the drill bit as a guide, put the threaded base block in place and verify the location is not impacted by the roof bracing.
- If the mounting block location is not obstructed, switch to the 6.35 cm (1/4 in.) drill bit and re-drill all the holes for the mounting block.
- Deburr the holes to remove any metal shards or remnants.

## After you finish

Install the Genetec™ hardmount on the vehicle.



## Installing the hardmount on the vehicle for SharpZ3 cameras

To permanently install SharpZ3 cameras on the patrol vehicle, you can use the hardmount: a base for the pan/tilt mount.

### Before you begin

Prepare your vehicle for a hardmount installation.

### What you should know

The hardmount includes the following components:

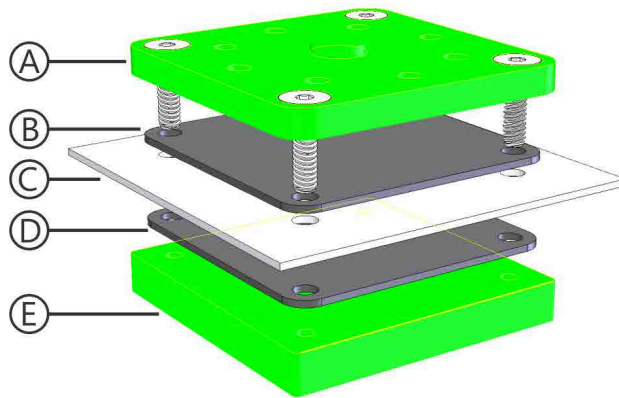

Component	
A	Upper mounting block
B	Upper rubber gasket
C	Vehicle roof
D	Lower rubber gasket
E	Threaded base block

- To complete these steps, you need the following:
  - Roll of tape
  - Hex key wrenches
- The camera mounting base has four parts:
  - Threaded base block
  - Two rubber gaskets
  - Upper mounting block

The upper and lower mounting blocks are installed above and below the roof with the rubber gasket in between to prevent water leaks and reduce vibration.

#### To install the hardmount on the vehicle:

- Place one of the rubber mounting gaskets on the threaded base block and hold the assembly underneath the mounting location.

**TIP:** After you align the gasket and base block, hold them in together using tape.

- 2 On the roof of the vehicle, align the second gasket on the mounting location, and then align the upper mounting block.
 

**TIP:** Use a hex key wrench to help align the screw holes.
- 3 Insert the four flat-head socket-cap screws into the mounting holes and tighten them using a diagonal pattern.

## Attaching the SharpZ3 pan/tilt/roll bracket to the hardmount

After you attach the hardmount to your vehicle, you can attach the camera using the pan/tilt/roll bracket.

### Before you begin

[Install the SharpZ3 hardmount on the vehicle.](#)

### What you should know

- To attach the camera, you need the following tools:
  - Socket wrench
  - Phillips screwdriver
- The camera mounting base has four parts:
  - Threaded base block
  - Two rubber gaskets
  - Upper mounting block

The upper and lower mounting blocks are installed above and below the roof with the rubber gasket in between to prevent water leaks and reduce vibration.

#### To attach the camera using the pan/tilt/roll bracket:

- 1 Assemble the pan/roll bracket hardware using the included documentation.
- 2 Attach the pan/roll bracket to the hardmount using four hex-head cap screws, flat washers, and split washers as shown in the included documentation.

#### NOTE:

- Set the alignment for the bracket to allow the bracket to pivot from forward to 90 degrees to the side.
- Do not over-tighten because you still need to aim the camera later.



- 3 Slide the camera onto the tilt bracket, with the bracket's open notch to the top. Leave about a 2.5 cm (1 in.) gap between the back of the bracket and the camera.
- 4 Attach the camera to the bracket using the Phillips pan head screws, serrated washers, and flat washers.

- 5 Attach the assembled camera and tilt bracket to the pan/roll bracket using hex-head cap screws, flat washers, and split washers.

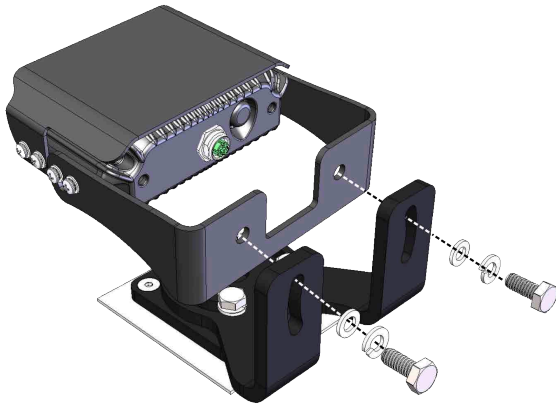

# Installing the SharpZ3 camera using the magmount

---

If you need to frequently move or remove the cameras from the patrol vehicle roof, you can install the cameras using the universal mounting bracket and pan/tilt mount with a magnetic base.

## Before you begin

Read [About camera mounting](#) on page 63.

## What you should know

**WARNING:** Do not remove the silicone boots covering the magnets. Genetec Inc. is not responsible for scratches to the vehicle's paint caused by contact with bare magnets.

### NOTE:

- The magmount uses extremely strong magnets and is difficult to remove from the vehicle roof. To adjust the camera's position after it is attached, you can loosen the bolts rather than attempt to move the entire mount.
- The holding power of the magnetic mounting system depends on surface finish, surface flatness, and thickness of the steel mounting surface. Keep the mounting surface and magnets clean, dry, and free of foreign particles that would prevent full surface contact.

To complete these steps, you need the following:

- Socket wrench
- Phillips screwdriver

### To install the camera using the magmount:

- 1 Assemble the magmount base using the instructions included with the magmount kit.

**TIP:** Properly positioned the camera before tightening the bolts.

- 2 Attach the pan/tilt/roll bracket to the magmount base using four hex bolts.

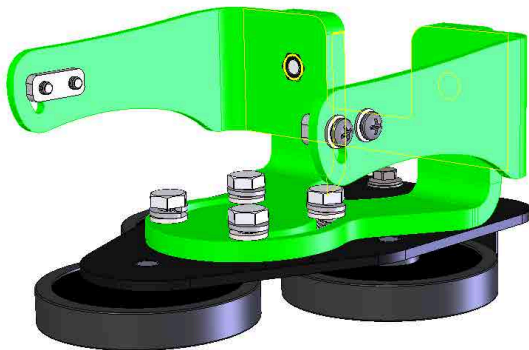

- 3 Attach the camera to the pan/tilt/roll bracket.



- 4 Verify that the roof of your vehicle is clean, dry, and free of debris, and then place the mounted camera in the desired position on the patrol vehicle.

**NOTE:** To reduce the chance of the vehicle roof being visible in the license plate images, select locations that are as close as possible to the corners of the roof.

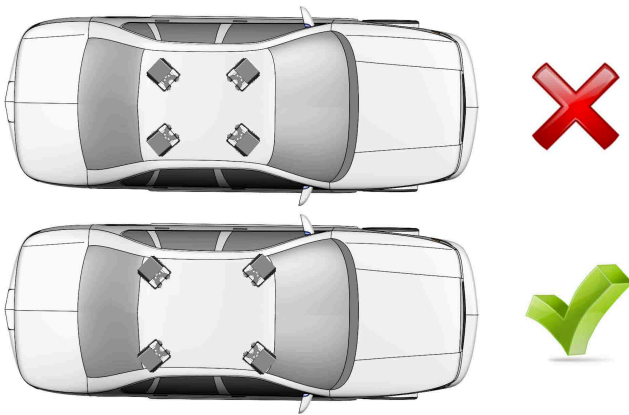

- 5 Install the grooved end of the universal window seal to your vehicle's passenger window. You can cut the seal as needed to fit your window.

# Lightbar camera installation

SharpZ3 cameras can be attached to the patrol vehicle's lightbar using the SharpZ3 lightbar bracket.

## About the lightbar bracket

Using Genetec™ lightbar brackets, you can mount up to four SharpZ3 cameras on the patrol vehicle.

### Lightbar mounting bracket overview

Before installing the lightbar bracket on the patrol vehicle's lightbar, familiarize yourself with components:

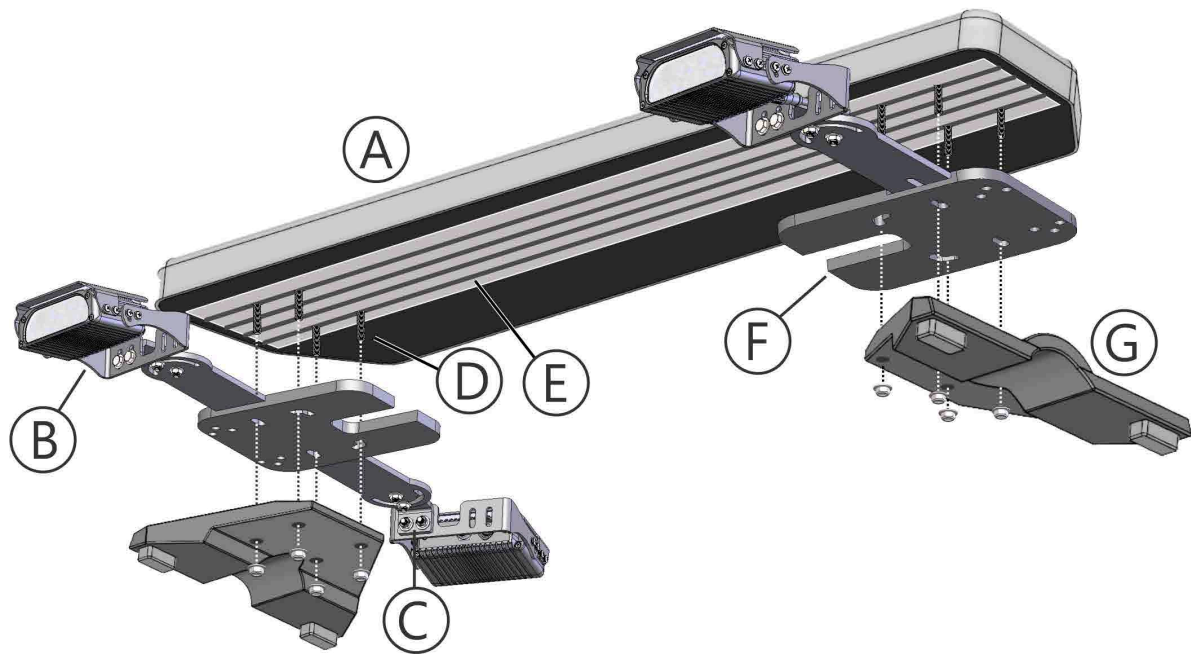

Component	Description
A	Patrol vehicle lightbar To verify that your lightbar is compatible with the lightbar bracket, contact your AutoVu™ Sales representative.
B	Tilt bracket Provides vertical tilt adjustment and some roll adjustment.
C	Pan bracket Provides horizontal pan adjustment. You can connect the pan bracket to the left or right side of the tilt bracket.
D	Mounting bolts Use the mounting bolts included with the hardware.
E	Slide bars Compatible lightbars include slotted slide bars so that you can adjust the position of the mounting bolts.

	Component	Description
F	Spacer plate	The spacer plate must be rotated according to which side of the vehicle it is being installed on as shown in the diagram.  <b>NOTE:</b> For some lightbar models, the spacer plate is unnecessary. For information on the hardware required for your lightbar, refer to the documentation included with the lightbar camera bracket.
G	Mounting base	The lightbar mounting bracket is installed between the lightbar and the mounting base.

## Installing the SharpZ3 camera on a lightbar

If the patrol vehicle includes one of the supported lightbars, you can install SharpZ3 cameras using the lightbar mounting bracket.

### What you should know

- The SharpZ3 lightbar mounting bracket is compatible with several lightbars from Whelen®, Code3, and SoundOff Signal®. To verify that your lightbar is compatible, contact your AutoVu™ Sales representative.
- When installing the spacer plate, the orientation of the plate depends on which side of the vehicle you are installing the cameras on.
- You can attach the pan bracket to either the left or right side of the tilt bracket. You can change the mounting position for a better fit at the end of the installation.

To complete these steps, you need the following:

- Socket wrench
- Phillips screwdriver

**NOTE:** The instructions and graphics in this section are for example only. Additional steps might be required depending on the type of lightbar installed on the vehicle.

#### To install SharpZ3 cameras on a lightbar:

- 1 Assemble the lightbar mounting bracket using the instructions included with the hardware.

**TIP:** Do not tighten the bolts until after you have properly positioned the cameras.

- 2 Separate the lightbar from its mounting base.

- 3 Remove the mounting bolts from the slide bars.

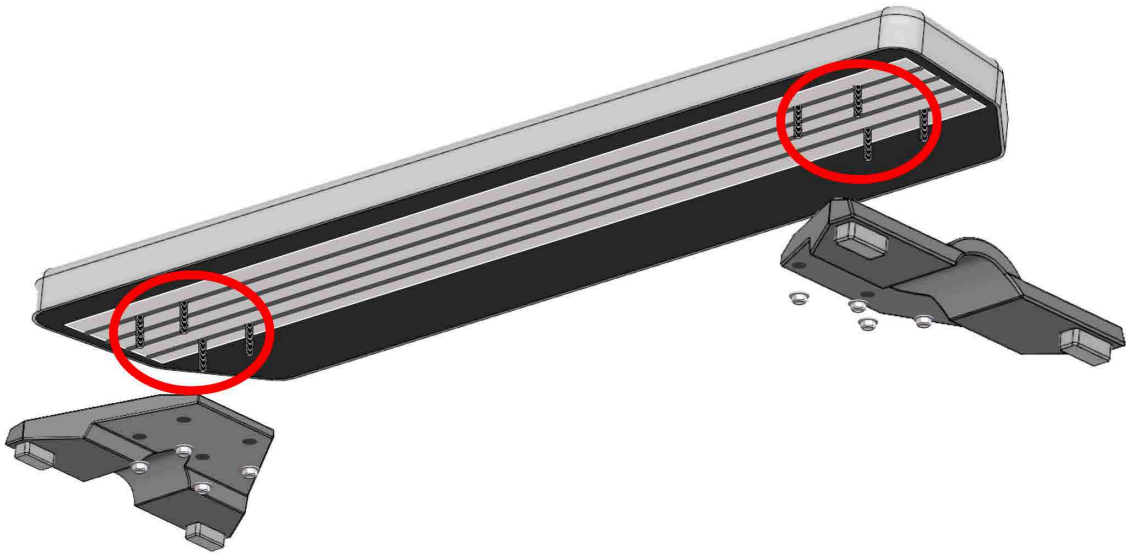

- 4 Install the new carriage bolts in the slide bars.
  - a) Align the AutoVu™ lightbar bracket under the lightbar and find the slide bar slots that match the bracket mounting holes.
  - b) Install the four carriage bolts in the appropriate slide bar slots.

**NOTE:** 1/4" and 5/16" carriage bolts are included with the lightbar mounting bracket. Select the bolts that are appropriate for the mounting holes in the lightbar base.
- 5 Install the AutoVu™ lightbar bracket between the lightbar and the lightbar base and fasten the assembly using the appropriate washers and locknuts as shown in the documentation included with the hardware.

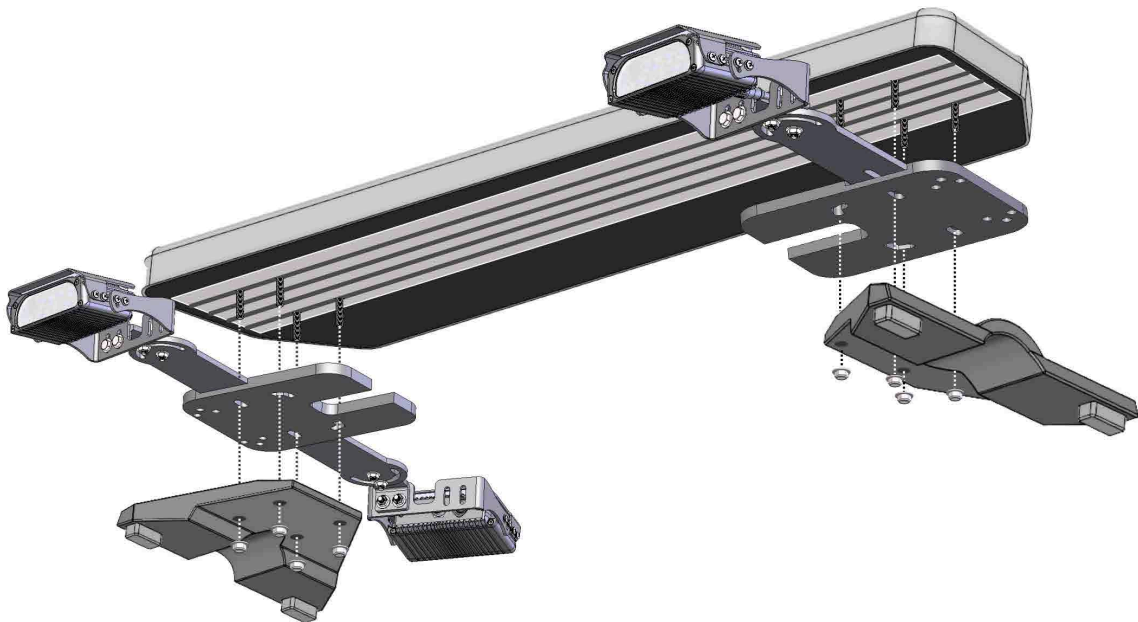

- 6 Install the assembled lightbar on the patrol vehicle.



- 7 Adjust the position of the mounting bracket by sliding it to the front or back, then tighten the fastening bracket.

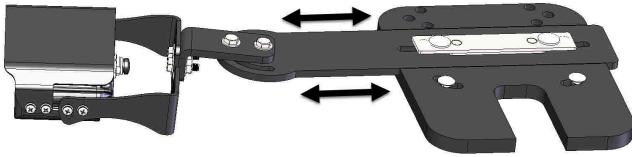

### After you finish

- [Align the cameras](#) so that license plates of passing vehicles are within the camera's field of view.
- Tighten the remaining fasteners on the lightbar mounting bracket.

# Drilling a camera cable hole

---

For installations with cameras that are hardmounted or attached to the patrol vehicle lightbar, you must drill a cable hole in the roof of the vehicle for each camera.

## Before you begin

- Install the camera using the [hardmount bracket](#) or [lightbar bracket](#).
  - NOTE:** If you are installing cameras using [magmounts](#), you do not need to drill holes in the vehicle roof.
- For hardmount installations, [prepare the vehicle for camera installation](#).

## What you should know

This procedure includes the use of cable glands. Alternatively, you can use butyl tape to seal the cable penetrations. If you use butyl tape, a 0.6 cm (¼ in.) hole can accommodate one camera cable, and a 1.3 cm (½ in.) hole can accommodate two camera cables. If you use this method, install a rubber grommet to protect the cable and account for the grommet when calculating the hole size.

To complete these steps, you need the following:

- **Electric or battery powered drill and drill bits:** Required when running cables through the vehicle roof or body panels.
- **Hole saw or stepping drill bit:** For cable penetrations, you can use a stepping drill bit or you can use a fine-toothed hole saw designed for vehicle body panels which is depth-regulated and includes a pilot drill bit.
- **Grease pencil:** Used to mark support locations on the roof of the vehicle.
- **Center punch:** Used to mark drilling locations.
- **Cable glands:** Required when sealing wire holes drilled in the vehicle's roof.

**NOTE:** Cable glands are required for all cable penetrations. Ensure that you have the appropriate glands in installing a cellular antenna or satellite navigation antenna.

- **Butyl tape and isopropyl alcohol:** Required for sealing any cable penetrations that do not use a cable gland.

### To drill camera cable holes in the vehicle:

- 1 Choose an appropriate cable gland for the 0.6 cm (¼ in.) camera cable.
  - WARNING:** Do not run more than one cable through a cable gland.
- 2 Place the cable gland on the section of the vehicle roof where you intend to pass the cable. Use a pencil to trace the outline of the cable gland.

**IMPORTANT:** The hole should be slightly smaller than the outline of the cable gland so that the cable gland collar can grip the vehicle's roof.

- 3 Check that both sides of the roof are clear of anything that could be damaged, and then drill the hole.
- 4 Deburr the holes to remove any metal shards or remnants.
- 5 Install the cable gland in the camera cable hole.
- 6 Pass the camera cable through the cable gland.

Leave approximately 20 cm (8 in.) of cable to allow the connection to the camera. A simple distance check is to lay the cable across the hardmount plate. To ensure that you have a proper loop for connecting to the camera, the tip of the connector should reach to the far side of the plate.

# SharpZ3 cabling recommendations

---

When installing the cabling of a SharpZ3 system, follow these practices to avoid damage to the cables or to the vehicle.

**WARNING:** Failure to follow the supplied instructions or information might result in loss of data or damage to hardware and will void the warranty.

## Recommendations

- Route and secure cables so they are clear of the vehicle's moving parts, especially the steering wheel, shift lever, parking brake, sliding seat tracks, doors, or any of the vehicle's controls.
- Secure all wiring with cable clamps or electrical tape so that no bare wiring is exposed.
- Cables connected to the computer docking station must allow enough slack so that the user can adjust the computer without pulling the cables.
- Route power wires from the battery through the vehicle firewall and away from abrasion, preferably routed through existing wire channels under the door sills where they remain protected.
- Use rubber cable glands or rubber grommets to prevent damage to wires that pass through the vehicle body or firewall. Seal the holes to prevent water from entering the vehicle.

## Things to avoid

- Do not install this product or route any cables in air bag deployment areas. Equipment mounted in the air bag deployment area can damage or reduce the effectiveness of the air bag, or become projectiles that could cause serious personal injury or death. Refer to the vehicle's owner manual for the air bag deployment area. The user and installer assume full responsibility for determining proper mounting location, based on providing ultimate safety to all passengers inside the vehicle.
- Do not route wires where they might be exposed to temperatures above 85°C (185°F), such as near the engine manifold. If the insulation heats up, wires may become damaged, resulting in a short circuit, malfunction, or permanent damage to the product.
- When securing hardware with screws, do not allow the screws to come into contact with any electrical lead.
- Do not route wires through areas that are particularly susceptible to vibration. Vibration can damage wires or insulation, resulting in a short circuit or other damage to the vehicle.

# Camera cable connection

To connect a SharpZ3 camera, you must terminate the camera cable with an RJ45 connector and connect the M12 x-code connector to the camera.

Note the following about the SharpZ3 camera connection:

- The SharpZ3 camera uses a standard Cat6a Ethernet cable.
- An EZ-RJPRO™ HD crimp tool is included with the AutoVu™ Alignment Kit.
- New RJ45 connectors are included with every SharpZ3 system.

## Terminating the SharpZ3 camera cable

Before you can connect the SharpZ3 camera cable to the base unit, you must terminate the cable with the provided RJ45 connector.

### Before you begin

- [Install the cameras](#) on the patrol vehicle.
- [Drill the camera cable holes](#).
- [Run that camera cables](#) to the base unit location.
- Cut the camera cables to the correct length.

### What you should know

To complete these steps, you need the following:

- **Depth-controlled cable jacket stripper:** Recommended for stripping the cable jacket to avoid damage to the internal conductors. The Cyclops stripping tool is included with the AutoVu™ Alignment Kit.
- **Wire stripper:** Required for stripping wire insulation.
- **RJ45 crimp tool:** Use a professional quality tool for proper crimping. The EZ-RJPRO® HD Crimp Tool is included with the AutoVu™ Alignment Kit.

The SharpZ3 camera cable is a Cat6a network cable with a plastic spline separating four twisted pairs.

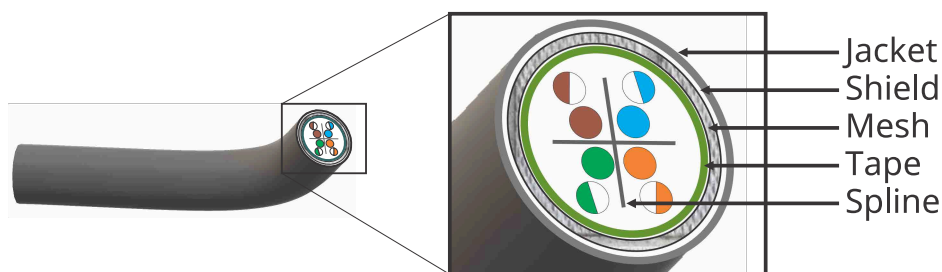

### To terminate the camera cable:

- 1 Slide the strain relief boot over the unstripped camera cable.  
You can do this after you strip the cable, but it is easier to do it first.

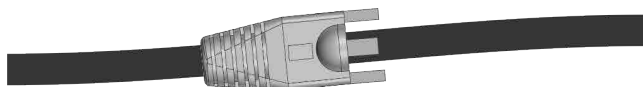

- 2 Using the cable jacket stripper, strip approximately 5 cm (2 in.) from the cable jacket.
- 3 Remove the metal shield tape.

**IMPORTANT:** Do not remove the wire mesh.

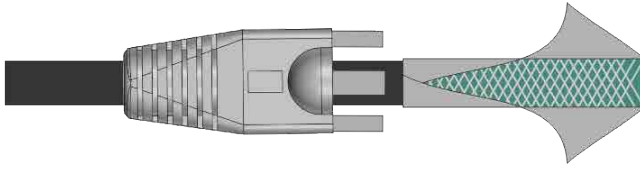

- 4 Separate the strands of the wire mesh and cut off all but two strands.
- 5 Wrap the strands around the cable jacket.

**TIP:** To keep the cable diameter as small as possible, do not overlap the wires.

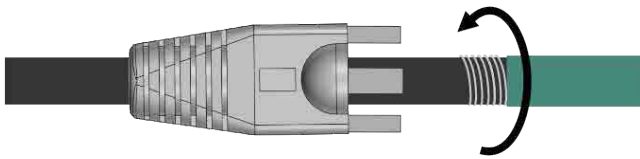

- 6 Wrap the provided copper tape around the strands.

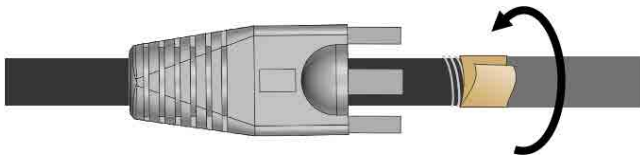

- 7 Remove the plastic tape.

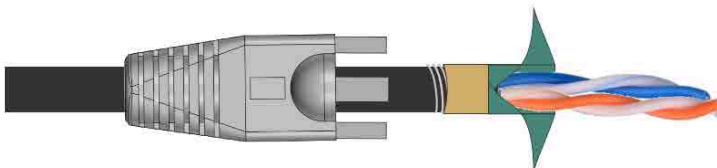

- 8 Cut off the plastic spline.

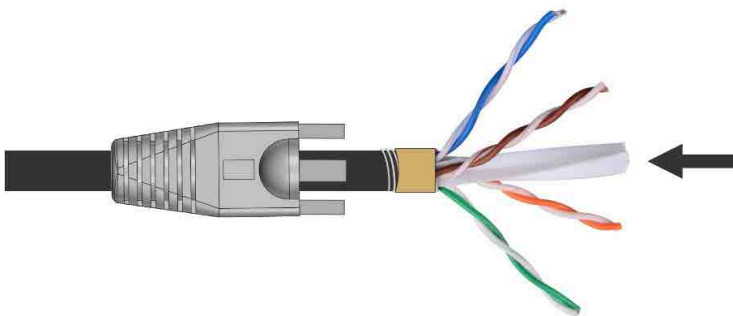

- 9 Arrange the conductors according to the EIA-T568B standard. For more information, see [Conductor arrangements for SharpZ3 cameras](#) on page 42.

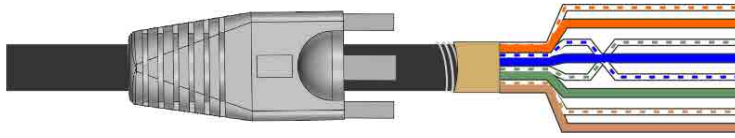

- 10 Insert the wires into the EZ-RJ45 connector.  
11 Slide the connector over the copper tape.

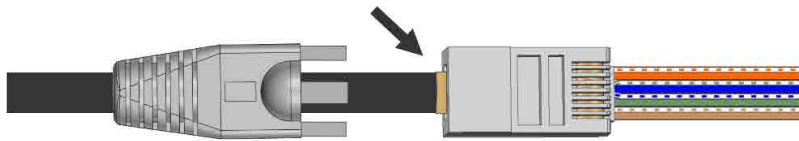

- 12 Confirm the wire order still matches the EIA-T568B standard.  
13 Twist the wires so that they can easily pass through the crimp tool.  
**TIP:** If required, pull the wires so that the RJ45 connector slides farther over the copper tape.  
14 Slide the strain relief boot into place and insert the plastic prongs into the RJ45 connector.

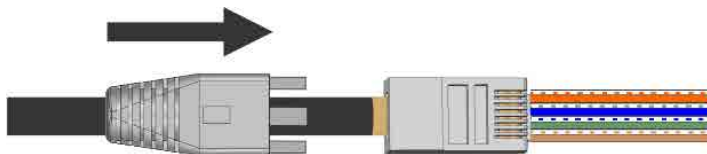

- 15 Crimp the connector using the EZ-RJ45 crimp tool.



## Conductor arrangements for SharpZ3 cameras

The following table lists the conductor arrangements for SharpZ3 cameras

You must terminate the SharpZ3 camera cables according to the EIA-T568B conductor arrangement.

Pin #	EIA-T568B
1	White/Orange
2	Orange
3	White/Green
4	Blue
5	White/Blue
6	Green
7	White/Brown
8	Brown



## Connecting the camera cable

To connect the camera cable to the camera, you must first install the SharpZ3 camera and terminate the camera cable.

### What you should know

- The camera cable uses an M12 X-coded connector.
- No tools are required when connecting the camera cable.

#### To connect the camera cable to the SharpZ3 camera:

- 1 Remove the plastic protector cap from the camera.
- 2 Apply a small amount of dielectric compound (included) on the cable connector threads.

**IMPORTANT:** Do not let the dielectric compound come in contact with the inside of the cable connector.



- 3 Align the notch on the cable connector with the notch on the camera port.

- Connect the cable to the camera and tighten the connection is snug, then tighten an additional ¼ turn by hand.  
As you turn the connector ring clockwise, jiggle the connector up and down to make sure that the cable connection is tight enough.

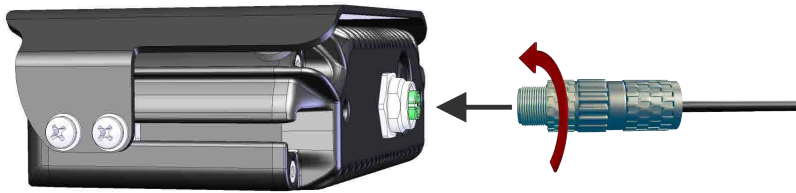

**WARNING:**

- Do not overtighten the connector.
- Only tighten the front of the connector. Tightening the back of the connector will break the camera.

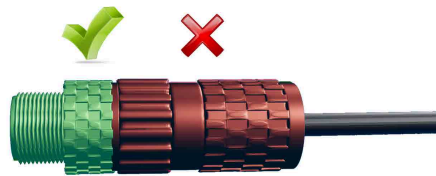

### Base unit camera connections

Depending on configuration of your SharpZ3 system, you can connect up to four SharpZ3 cameras to the base unit.

The following image shows a SharpZ3 system with a four-camera ALPR module:

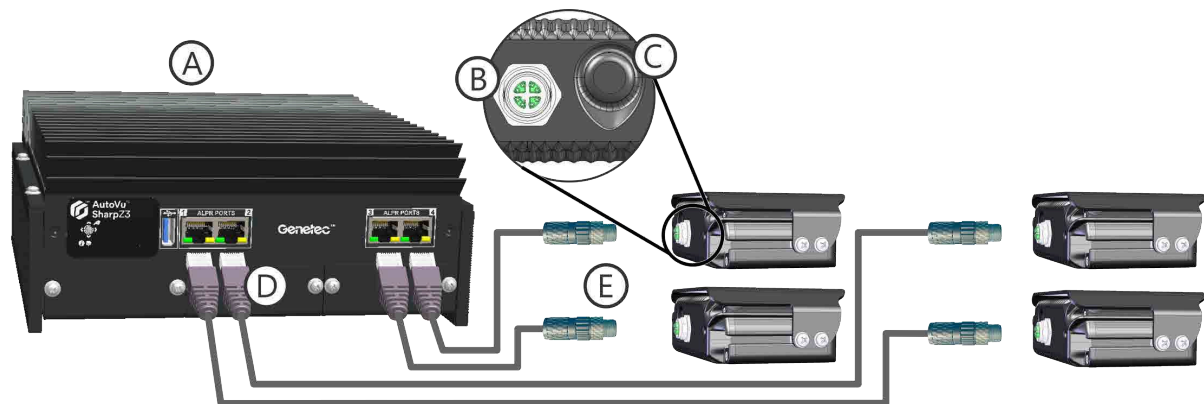

Component	Description
A	SharpZ3 base unit Responsible for ALPR processing.
B	Camera connector Remove the protective cap before connecting the camera cable.
C	Sealed pressure equalizer Do not remove.



	Component	Description
D	ALPR camera ports	The SharpZ3 Cat6a camera cable connects to the ALPR module with an RJ45 connector.
E	Camera cable	The SharpZ3 Cat6a camera cable connects to the SharpZ3 camera with an M12 X-coded connector.

---

## Sealing cable holes in the patrol vehicle

---

To ensure a watertight installation, you must seal all cable holes drilled in the body of the vehicle.

### What you should know

- The following steps are not required if you are using cable glands to seal the cable holes.
- If you run more than one cable through a cable hole, seal the hole using a rubber grommet and butyl tape, not a cable gland.

#### To seal the cable holes:

- 1 Install a rubber grommet in the cable hole to prevent damage to wires that pass through the vehicle body.
- 2 Clean the area around the cable hole using isopropyl alcohol or rubbing alcohol.
- 3 When the area is dry, use about a 8 cm (3 in.) section of butyl tape to wrap the cable and the area around the base of the cable gland.
- 4 Press the butyl tape into place to ensure a tight seal.

# Camera alignment

To ensure that your SharpZ3 cameras read license plates accurately, you must properly align them after they are mounted on the patrol vehicle.

- Determine which alignment scenario applies to your situation.
- Make sure you have a AutoVu™ Alignment Kit, with the following tools: tape measure, plumb-bob weight, chalk, and a vertically adjustable target.
- Install and secure the SharpZ3 cameras.
- Have a laptop computer available. To verify that the cameras are aligned, you must connect to the Sharp Portal, which displays the camera video feed.
- Make sure the camera is installed so that the camera roll is parallel to the ground:

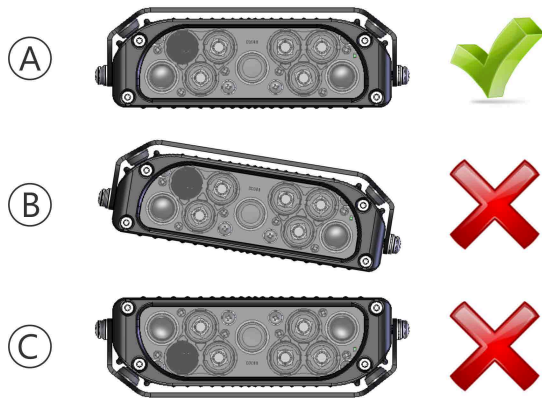

A	Level to ground
B	Not level to ground (body roll)
C	Upside down

### Related Topics

[Alignment scenarios for SharpZ3 cameras](#) on page 84

[About camera mounting](#) on page 63

## Alignment scenarios for SharpZ3 cameras

There are several possible alignment configurations for SharpZ3 cameras. The correct configuration depends on your AutoVu™ deployment type and vehicle type.

The following table lists the most common alignment scenarios. [Set up the tripod](#) and align your cameras using the X, Y, and D measurements in the following table in conjunction with the instructions for [setting up the tripod](#).

If the provided alignment scenarios do not apply to your installation, contact your AutoVu™ representative.

Type of deployment	Your camera configuration	Car	Truck/SUV
		Approximate height: 58.8 in. or 1.49 m	Approximate height: 68.4 in. or 1.73 m

Type of deployment	Your camera configuration	Car	Truck/SUV
<b>Law enforcement</b>	<b>Front cameras</b>		
	<b>Left and right cameras</b>		
	• SharpZ3 (16 mm)	<ul style="list-style-type: none"> <li>• X = 73 in. (1.86 m)</li> <li>• Y = 130 in. (3.30 m)</li> <li>• D = 149 in. (3.79 m)</li> </ul>	<ul style="list-style-type: none"> <li>• X = 87.5 in. (2.22 m)</li> <li>• Y = 161.5 in. (4.11 m)</li> <li>• D = 183.5 in. (4.67 m)</li> </ul>
	<b>Left and right cameras</b>		
• SharpZ3 (16 mm)	<ul style="list-style-type: none"> <li>• X = 68.5 in. (1.74 m)</li> <li>• Y = 126.5 in. (3.21 m)</li> <li>• D = 144 in. (3.66 m)</li> </ul>	<ul style="list-style-type: none"> <li>• X = 79 in. (2.00 m)</li> <li>• Y = 140 in. (3.56 m)</li> <li>• D = 160.5 in. (4.08 m)</li> </ul>	
<b>Law enforcement</b>	<b>Rear cameras</b>		
	<b>Left and right cameras</b>		
	• SharpZ3 (12 mm)	<ul style="list-style-type: none"> <li>• X = 71.5 in. (1.81 m)</li> <li>• Y = 62.5 in. (1.59 m)</li> <li>• D = 95 in. (2.41 m)</li> </ul>	<ul style="list-style-type: none"> <li>• X = 80 in. (2.03 m)</li> <li>• Y = 68.5 in. (1.74 m)</li> <li>• D = 105.5 in. (2.67 m)</li> </ul>
	<b>Left and right cameras</b>		
• SharpZ3 (12 mm)	<ul style="list-style-type: none"> <li>• X = 68.5 in. (1.74 m)</li> <li>• Y = 74.5 in. (1.90 m)</li> <li>• D = 101 in. (2.57 m)</li> </ul>	<ul style="list-style-type: none"> <li>• X = 80.5 in. (2.04 m)</li> <li>• Y = 87 in. (2.21 m)</li> <li>• D = 118.5 in. (3.01 m)</li> </ul>	
<b>On-street parking (city streets)</b>	<b>Front cameras only (no rear cameras in this configuration)</b>		
	<b>Left and right cameras</b>		
<b>Off-street parking (parking lots)</b>	<b>Wide row lots (two-way traffic)</b>		
	<b>Genetec Patroller™ tendency to drive closer to the right (for right-hand traffic flow)</b>		
	<b>Left camera</b>		
	• SharpZ3 (12 mm)	<ul style="list-style-type: none"> <li>• X = 69 in. (1.76 m)</li> <li>• Y = 69 in. (1.76 m)</li> <li>• D = 98 in. (2.49 m)</li> </ul>	<ul style="list-style-type: none"> <li>• X = 81.5 in. (2.07 m)</li> <li>• Y = 81.5 in. (2.07 m)</li> <li>• D = 115 in. (2.93 m)</li> </ul>
<b>Right camera</b>			
• SharpZ3 (12 mm)	<ul style="list-style-type: none"> <li>• X = 62.5 in. (1.58 m)</li> <li>• Y = 62.5 in. (1.58 m)</li> <li>• D = 88 in. (2.24 m)</li> </ul>	<ul style="list-style-type: none"> <li>• X = 71.5 in. (1.81 m)</li> <li>• Y = 71.5 in. (1.81 m)</li> <li>• D = 101 in. (2.56 m)</li> </ul>	

## Attaching the target to the tripod

After you determine where to set up the tripod, you must attach the target to it, and raise it to the proper height for camera alignment.

**To attach the target, refer to the illustration below and the steps that follow:**

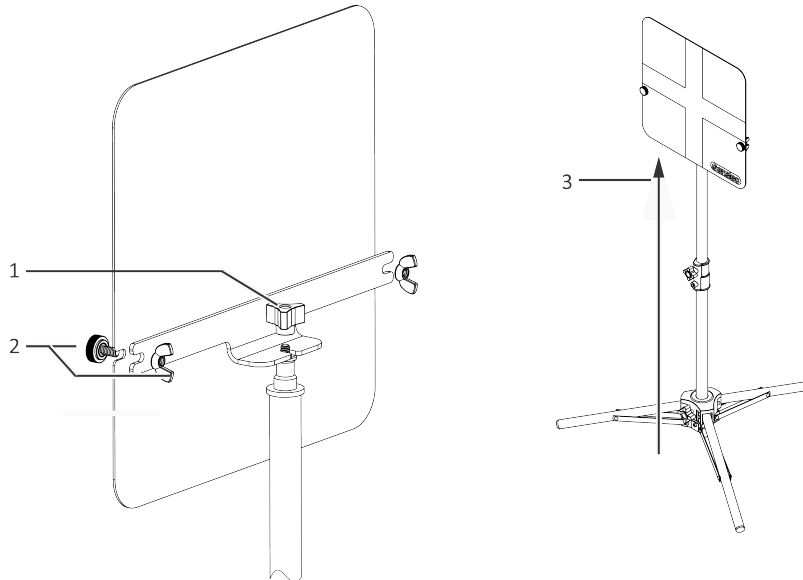

- 1 Attach the three-arm knob to the tripod base using the provided wing nut.
- 2 Attach the plastic thumb-head screw to the wing nut (both sides).
- 3 Raise the tripod to its full length. The center of the target should be 36 in. (0.9 m) from the ground.

## Setting up the tripod

To align a camera installed on a patrol vehicle, you must determine where to set up the tripod that holds the alignment target.

### Before you begin

Use the alignment scenarios to find the X, Y, and D values that apply to your situation.

### What you should know

Use the following illustration to help you measure X, Y, and D relative to your vehicle:

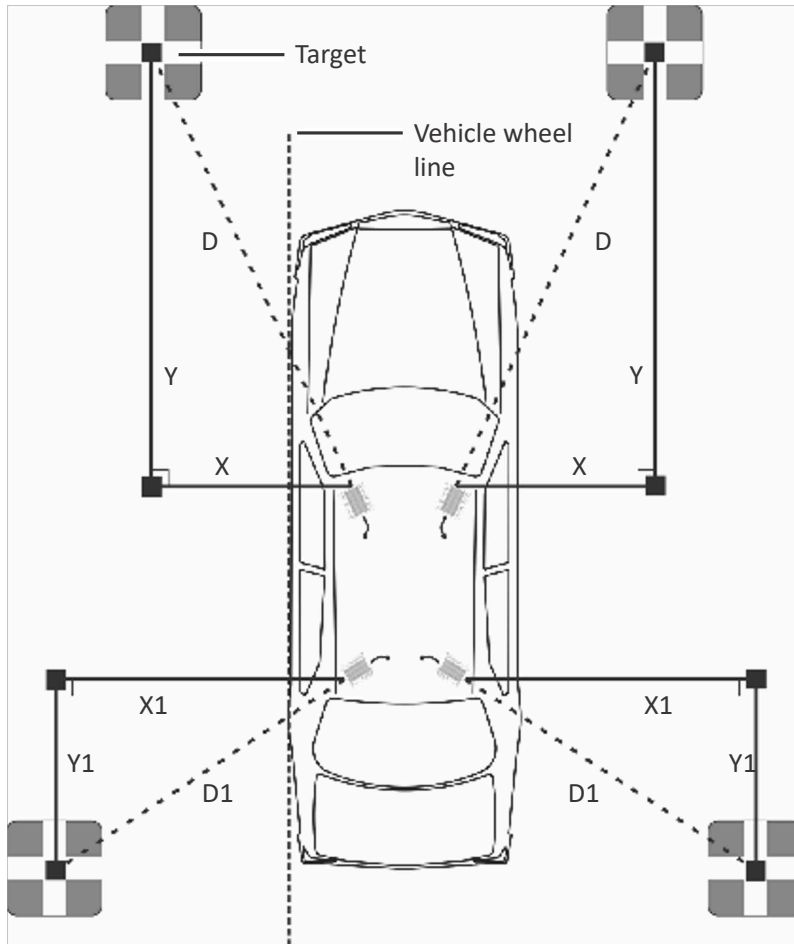

**TIP:** Using the vehicle's wheels (vehicle wheel line) as a reference can help you ensure the X and Y measurements are perpendicular and parallel as required.

**NOTE:** The values X, Y, and D refer to alignment distances only, not your camera's plate reading distances.

**To set up the tripod:**

- 1 Secure the end of the measuring tape to the camera using one of the hook and loop clips.
- 2 From the height of the camera lens, measure the X distance.

Measure parallel to the ground and perpendicular to the vehicle's wheel line. Use the plumb-bob weight and chalk to mark the ground where X falls.

- 3 From the X point you marked on the ground, measure the Y distance.

Measure on the ground, and parallel to the vehicle wheel line. Use the chalk to mark Y on the ground.

- 4 To validate D, measure the D distance from the height of the camera lens.

Measure parallel to the ground. Use the provided plumb-bob weight to see where D falls on the ground. If you are more than three inches off from the Y point, you must re-measure X and Y.

- 5 Set up the tripod on the Y point you marked, raise the target so that its center is 36 in. (0.9 m) from the ground, and orient the target so it's facing the camera.

## Aligning the SharpZ3 cameras with the target

After you set up and position the tripod, you can use the live feed in the Sharp Portal to align the camera with the target. This ensures that your SharpZ3 cameras read license plates accurately.

### Before you begin

[Set up the tripod.](#)

#### To align the camera with the target:

- 1 [Log on to the Sharp Portal.](#)
- 2 Click **Dashboard** > **Camera feeds** and select the *ALPR Camera* feed in the **Camera unit** list.
- 3 From the **Overlays** menu, select **Crosshairs**.  
Crosshairs are displayed on the video feed.
- 4 Adjust the pan/tilt angles of the camera as needed to align the crosshairs with the target.

### After you finish

Repeat the procedure for your other cameras, as needed.

# Peripheral hardware installation

This section includes the following topics:

- ["About SharpZ3 navigation hardware"](#) on page 90
- ["About installing wheel-imaging cameras in a SharpZ3 system"](#) on page 98
- ["About the AutoVu™ car camera switch"](#) on page 106



## About SharpZ3 navigation hardware

If it is important to know the precise location of the patrol vehicle, permit hits, and hotlist hits, the SharpZ3 trunk unit must include the Navigation option module.

The navigation expansion module provides additional navigation information. This information can be used with any type of AutoVu™ mobile deployment, but it is required for patrol vehicles running Genetec Patroller™ in *City Parking Enforcement with Wheel Imaging* mode.

The module is also mandatory for installations that include wheel-imaging cameras.

### How precise positioning is obtained

The navigation expansion module is connected to a satellite receiver that obtains satellite positioning information. The system also receives odometry information from the vehicle VSS or odometry sensor. This provides greater reliability than satellite positioning alone. For example, if you drive through a long tunnel, the satellite signal will be lost, but the odometry information lets the AutoVu™ system continue to track changes in the speed and direction of the vehicle.

The trunk unit is also connected to the vehicle's reverse signal (usually by tapping the reverse lights), and to the in-vehicle computer.

**NOTE:** To obtain precise positioning, you must calibrate the AutoVu™ navigation system in Genetec Patroller™.

## Satellite navigation hardware options

The satellite navigation hardware that must be installed on the patrol vehicle depends on whether the system includes the navigation expansion module and wheel-imaging cameras.

### Satellite navigation hardware

Installation type	Required satellite navigation hardware	Connector type	Connection location	Required drivers
Base unit with the navigation expansion module	Tallysman TW2412 GPS/GLONASS Antenna	SMA	Navigation expansion module GNSS port	None
Base unit without the navigation expansion module (GPS only)	GlobalSat BU-353S4 USB GPS Receiver	USB	In-vehicle computer USB port	Install drivers on in-vehicle computer (Genetec Patroller™ installation package: Drivers\BU-353S4 GPS Receiver)

## Installing the SharpZ3 satellite navigation hardware

To provide satellite coordinates for plate reads, you must install a satellite navigation antenna on the patrol vehicle.

### What you should know

- If the patrol vehicle uses wheel-imaging cameras, the base unit you install must include the SharpZ3 navigation expansion module so that the system can track the location of the vehicles associated with captured plate reads.
- For patrol vehicles that lack wheel-imaging cameras and a GPS source, you can install the basic USB GPS antenna.

To complete these steps, you need the following:

- **Electric or battery powered drill and drill bits:** Required when running cables through the vehicle roof or body panels.

The following procedure applies to all supported receivers and antennas and the general term "satellite hardware" is used.

#### To install the satellite hardware:

- 1 Install the satellite hardware on the vehicle's roof:
  - a) Ensure that the vehicle's roof is clean, dry, and free of debris.
  - b) Place the magnetized side of the satellite hardware on the vehicle's roof, and consider the following:
    - The satellite hardware requires an unobstructed view of the sky. This includes any objects near the hardware such as a light bar that might block the signal coming from satellites near the horizon.
    - You must install the satellite hardware at least 30 cm (12 in.) from any other antenna.
    - For best performance, install the satellite hardware at least 100 cm (40 in.) from the SharpZ3 cameras.
  - c) Create a cable penetration in the vehicle's roof and pass the satellite hardware cable through the hole using an appropriate cable gland.
    - For more information on drilling cable holes, see [Drilling the camera cable holes](#).
    - For more information on sealing the cable penetration, see [Sealing the camera holes](#).
- 2 Run the cable to the connection location.
  - If you are installing a Tallysman TW2412 GPS/GLONASS antenna, run the cable to the base unit.
  - If you are installing a GlobalSat BU-353S4 USB GPS receiver, run the cable to the in-vehicle computer.

**IMPORTANT:** Avoid bending the antenna cable sharply. Try to make all bends with a smooth radius.
- 3 Connect the satellite hardware to the SharpZ3 system.
  - If you are installing a Tallysman TW2412 GPS/GLONASS antenna, connects to the SMA connector on the navigation expansion module. For more information, see [Navigation expansion module connections](#) on page 48.
  - If you are installing a GlobalSat BU-353S4 USB GPS receiver, connects to the in-vehicle computer's USB port.

## Installing the GlobalSat GPS driver

If you are installing a GlobalSat BU-353S4 USB GPS receiver as part of a SharpZ3 system, you must install the required drivers on the in-vehicle computer.

### What you should know

If the base unit includes the navigation expansion module and uses the Tallysman TW2412 GPS/GLONASS antenna, you do not need to install any drivers.

#### To install the driver:

- 1 Turn on the in-vehicle computer and sign in to Windows using an Administrator account.
- 2 In the Genetec Patroller™ installation package, navigate to the driver location and double-click the driver file: **GlobalSat BU-353S4: Drivers\BU-353S4 GPS Receiver**
- 3 Follow the on-screen instruction to complete the installation process.

## About the odometry sensor

To ensure that the patrol vehicle's position is tracked and displayed accurately on the map, you must provide an odometry signal to the system. To do this, you can install an odometry sensor on the drive shaft of the vehicle.

Consider the following when planning your odometry sensor installation:

- If your patrol vehicle has a Vehicle Speed Sensor (VSS) or Output Speed Sensor (OSS), it is recommended to tap into that sensor instead of installing an odometry sensor.

**NOTE:** Some newer vehicles and electric vehicles do not include a VSS or OSS.

- You can install the odometry sensor on front-wheel drive or rear-wheel drive vehicles.
- In the following procedure, you must attach four evenly-spaced magnets to the drive shaft. If additional magnets are required due to the structure of the drive shaft, such as a shaft with a hexagonal cross section, contact your AutoVu™ representative.

**IMPORTANT:** If you are installing an odometry sensor to replace an existing magneto kit, you must remove the magneto kit magnets and install the magnets that are included with the odometry sensor.

- An odometry sensor installation includes the following hardware components:

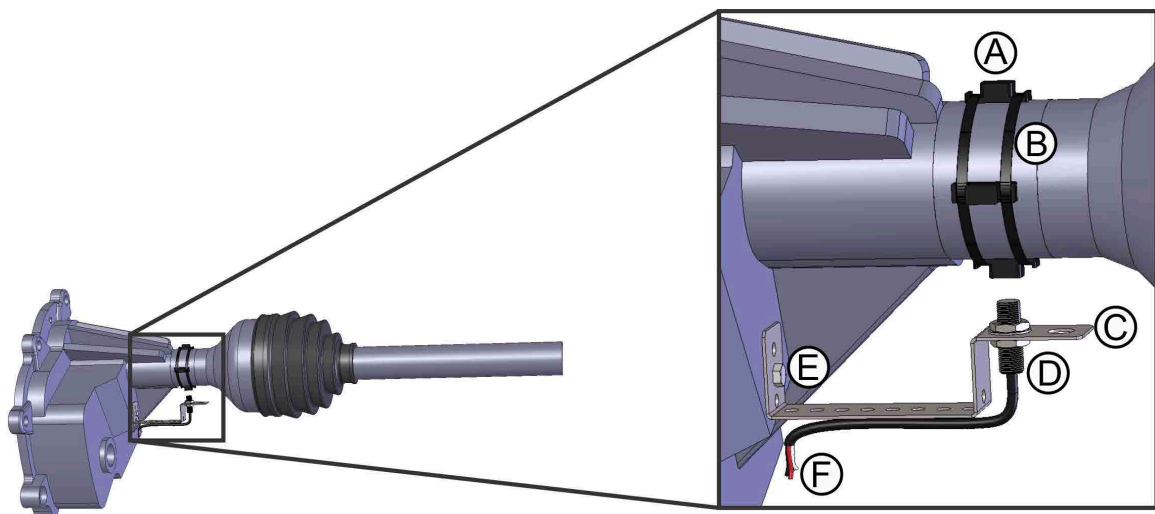

	Component
A	Magnets

	Component
<b>B</b>	Tie straps
<b>C</b>	Mounting bracket <b>NOTE:</b> The bracket in the image has been customized to fit the specific installation.
<b>D</b>	Odometry sensor
<b>E</b>	Bolt from the engine block or transmission case (or use self-tapping screws)
<b>F</b>	Odometry sensor cable

## Installing the odometry sensor

### What you should know

- To complete these steps, you need the following:
  - Jack stands or vehicle ramps
  - Electric drill
  - Stepping drill bit
  - Roll of tape
  - Tie straps
  - Strip of paper
  - Pencil
  - Wrenches
  - Flat blade screwdriver
  - Sandpaper
  - Epoxy (included)

#### To install the odometry sensor:

- 1 Raise and support the vehicle so that you can work on the drivetrain.

#### CAUTION:

- Never get under any vehicle that is only supported by jacks. Use jack stands or ramps.
- Do not use concrete blocks to support the vehicle.
- Always chock the wheels of the vehicle and set the parking brake.

- 2 Choose a mounting location for the odometry sensor.

- The sensor must be no farther than 1.9 cm ( $\frac{3}{4}$  in.) from the magnets.
- The mounting bracket must be installed on a surface that is immobile relative to the magnets. This means that the distance between the sensor and the magnets must be consistent, even when driving

on rough surfaces. The magnets will damage the odometry sensor if they come into contact during vehicle operation.

- To minimize the lateral movement of the sensor, install it as close as possible to the output of the transmission or differential.

The following drivetrain locations are recommended:

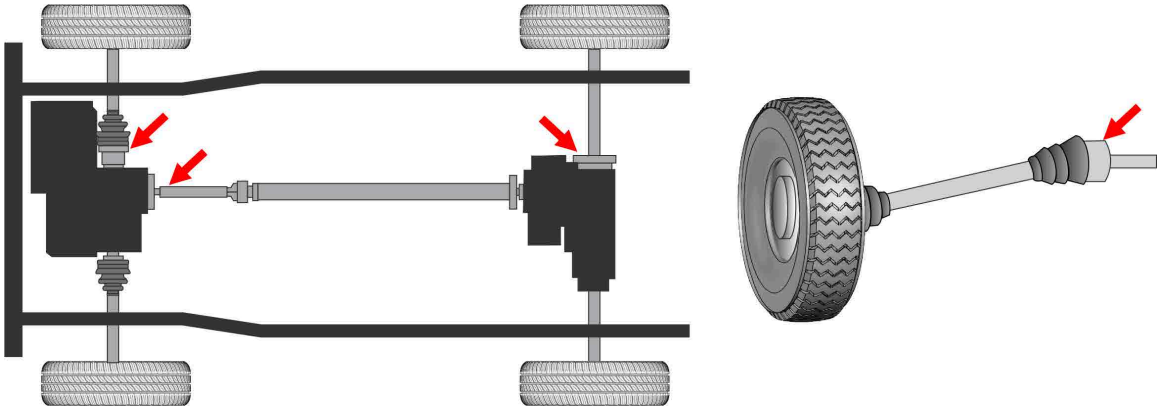

### 3 Mount the sensor bracket:

- Self-tapping screws are provided to attach the bracket to a surface under the vehicle. However, it is recommended that you use appropriate bolts, nuts and lock washers to secure the bracket. If possible, use an existing bolt from the transmission case or differential case.

**WARNING:** Drilling through the floor pan to mount the bracket is not recommended because the motion of the floor does not match the motion of the drive shaft. If you must drill through the floor pan, ensure that you do not damage fuel or electrical lines that might be embedded in the floor pan.

- If you are mounting the bracket to a crossmember, drill 0.5 cm (3/16 in.) holes and attach the bracket with 0.6 cm (1/4 in.) tapping screws.
- If you use a transmission bolt, drill the bracket as required to widen the hole.
- If only one mounting bolt is available, bend the bracket over an edge to prevent it from spinning.
- The installation examples used in this procedure show the odometry sensor mounted below the drive shaft, but note that the sensor can be oriented in any direction relative to the drive shaft.

### 4 Remove the protective rubber cap from the sensor, and then attach the sensor to the sensor bracket as close to the end of the bracket as possible.

Install a lock washer and a nut on each side of the bracket. Hand-tighten the nuts. The connection will be fully tightened at the end of the installation.



### 5 Bend the bracket as needed to aim the sensor at a point on the middle of the drive shaft.

**TIP:** To reduce vibration, bend the bracket so that it is as short as possible.

## 6 Prepare the magnet mounting location:

- a) Use the included sandpaper to remove surface rust from the expected magnet locations around the shaft.

If the magnet locations are already clean and rust-free, use sandpaper to roughen the surface to ensure that the epoxy adheres.

- b) Use the included alcohol wipe to clean the magnet mounting locations.

## 7 Identify the magnet mounting points:

- a) Wrap a strip of paper around the shaft.
- b) Mark the circumference of the shaft and cut the paper to match.
- c) Fold the paper in half twice, dividing it into four equal sections. Make the creases more visible using a marker. The creases will show the mounting location for the magnets.
- d) Wrap the strip of paper around the shaft and use a piece of tape to hold the paper in place.

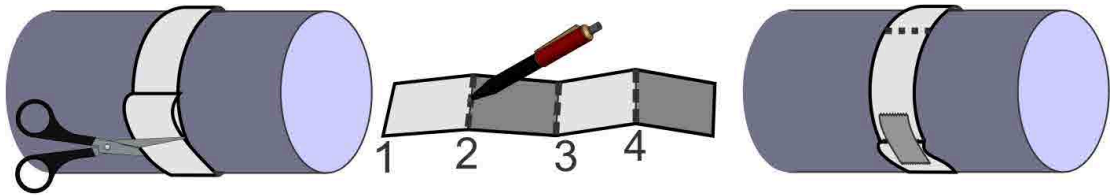

## 8 Secure the magnets to the shaft:

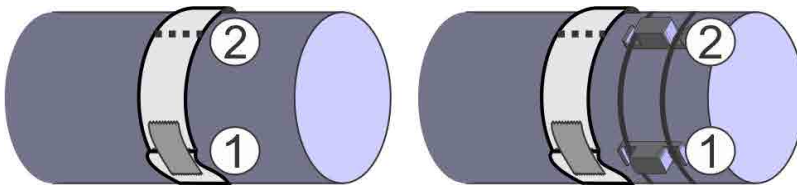

- a) Position the strip of paper so that the magnets will be installed beside the paper, directly in line with the sensor.
- b) Prepare the epoxy according to the instructions on the package.

**IMPORTANT:** The supplied epoxy hardens in 5 - 10 minutes. Read through the rest of the steps and prepare your work before securing the magnets.

- c) Apply epoxy to the back of the magnets and position the magnets beside the mounting locations marked on the strip of paper.
- d) Secure the magnets using two tie straps, making sure that the tie straps sit between the notches on the sides of the magnets.  
To tighten the tie straps, place the blade of a screwdriver against the tie strap lock, and use pliers to pull on the strap end.
- e) Cut off any excess strap and ensure that the tie strap locks do not contact the sensor when the shaft rotates.
- f) Verify that the magnets did not shift during tightening.

## 9 Adjust the sensor in the bracket:

- a) Make sure that the gap between the sensor and the magnets is no greater than 1.9 cm ( $\frac{3}{4}$  in.).  
Reposition the sensor to align with the magnets, if needed.
- b) When the sensor is in its final position on the mounting bracket, tighten the sensor mounting nuts to 31 Nm (23 ft·lbf).

## 10 Check for an existing hole in the floor pan that is suitable for passing the sensor cable to the base unit.

If you cannot find an appropriate hole in the floor pan, drill a hole and install a cable gland to protect the cable.

**WARNING:** Fuel lines and electrical cables are sometimes embedded in a vehicle's floor pan. Do not drill through the floor pan unless you are sure there are no hidden obstacles.

11 Run the cable to the base unit using a wire loom to protect the wires.

**WARNING:** Make sure that wires are routed away from exhaust pipes, shift rods, or any other hot or moving parts.

12 Connect the odometry sensor cable to the base unit as shown:

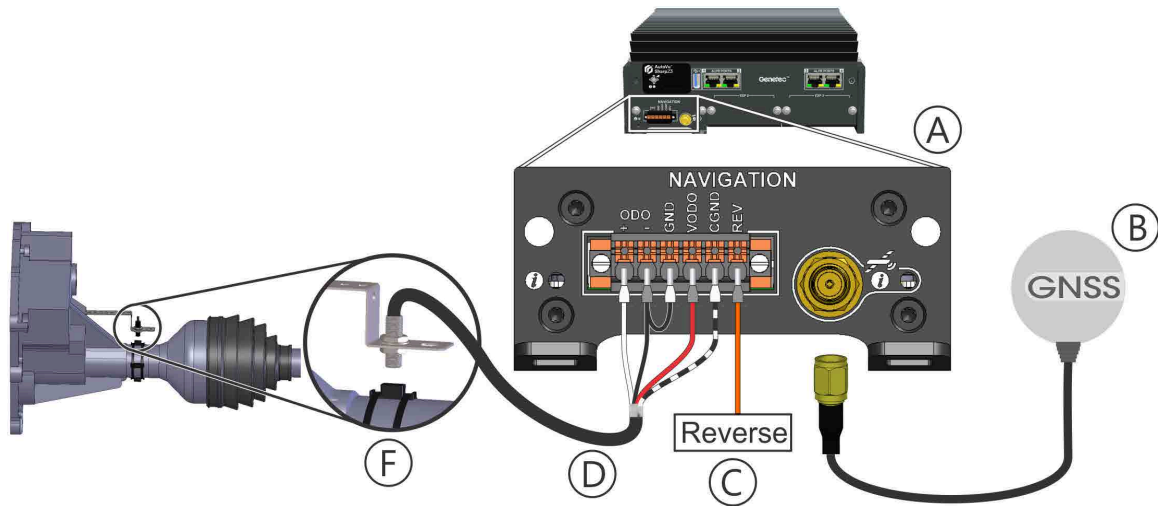

Component	Description	
A	Navigation expansion module	The navigation expansion module adds precise positioning to the SharpZ3 system.
B	Satellite navigation antenna	The GNSS satellite navigation antenna is connected to the base unit and works with the odometry inputs to provide precise georeferencing for the vehicles associated with the plate reads. For more information on which satellite navigation hardware to install, see <a href="#">Satellite navigation hardware options</a> on page 90.
C	Reverse signal	The SharpZ3 system is usually connected to the vehicle's reverse signal by tapping the reverse lights.
D	Odometry sensor cable connection	Connect the hardware to the base unit as shown in the diagram.
E	Odometry sensor	The odometry sensor provides wheel rotation information to the AutoVu™ system if a VSS signal is not available.

## Installing the cellular antenna

If the SharpZ3 system uses a cellular connection to transmit plate reads and to update hotlists and permits, you must install a cellular antenna on the patrol vehicle.

### Before you begin

- Install the base unit in the patrol vehicle.
- Lower the vehicle's headliner to gain access to the underside of the mounting location.

## What you should know

- You can install the cellular antenna on the vehicle roof or trunk.

To complete these steps, you need the following:

- Hole saw or stepping drill bit:** For cable penetrations, you can use a stepping drill bit or you can use a fine-toothed hole saw designed for vehicle body panels which is depth-regulated and includes a pilot drill bit.

### To install the cellular antenna on the vehicle:

- Place a cable gland on the location of the vehicle roof where you intend to pass the cable and use a grease pencil or other marker to trace the outline of the cable gland.  
The cable gland should have an outer diameter of 1.9 cm ( $\frac{3}{4}$  in.) and an inner diameter .95 cm ( $\frac{3}{8}$  in.).  
**IMPORTANT:** The hole should be slightly smaller than the outline of the cable gland so that the cable gland collar can grip the vehicle's roof.
- Verify that both sides of the roof are clear of anything that could be damaged, and then drill the cable hole.
- Deburr the holes to remove any metal shards or remnants.
- Install the cable gland in the cable hole.
- Pass the cable through the cable gland and run the cable to the ToughPad dock.
- Connect the antenna cable to the SMA connector on the ToughPad dock.

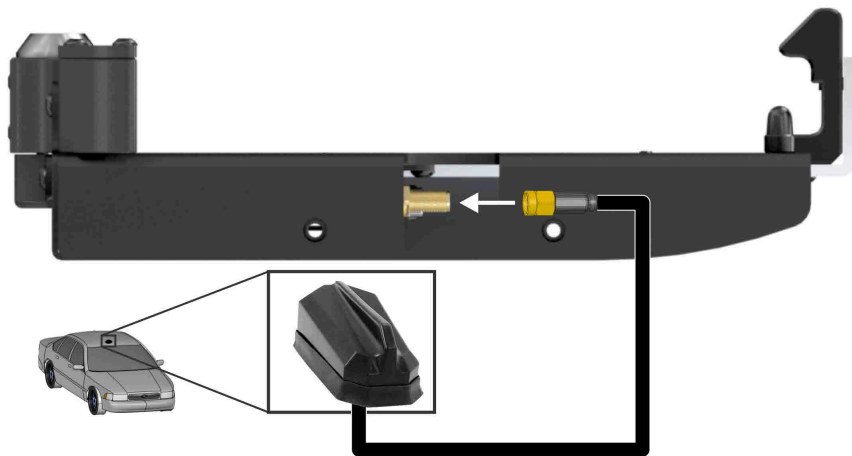

- Peel off the adhesive liner from the back of the antenna.

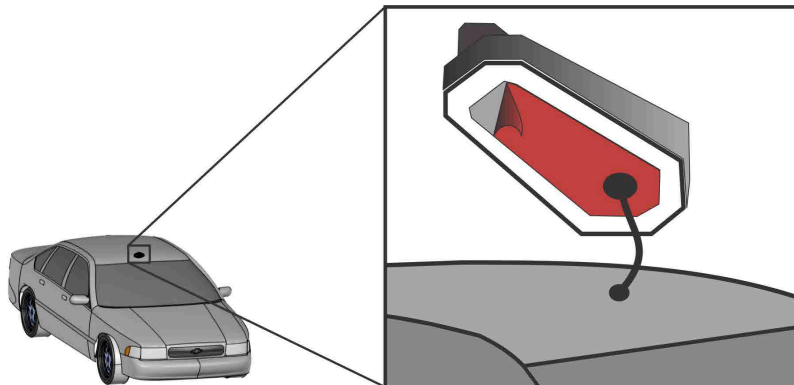

- Align the antenna as desired and place the antenna on the vehicle. Apply pressure to ensure surface contact.



# About installing wheel-imaging cameras in a SharpZ3 system

The AutoVu™ wheel-imaging camera enhances mobile automatic license plate recognition (ALPR) systems by attaching a photo of the vehicle's wheel to each license plate read and hit. When comparing wheel images from the patrol vehicle's first pass and second pass, you can use the wheel's valve stem (or other reference point) to see whether the wheel has moved even a short distance.

Combined with the AutoVu™ digital tire chalking feature, the wheel-imaging camera provides an additional layer of violation validation, reducing ticket challenges and enhancing time-limited parking enforcement efficiency.

To accurately record wheel images, the SharpZ3 system must include the Navigation expansion module. This allows the system to interface into the vehicle's odometry signal to know how far the patrol vehicle has traveled.

## Camera specifications

- Max. 2 MP (1920x1080) @ 30fps resolution
- Built-in 4 mm megapixel fixed lens
- Built-in IR illumination
- IP66/IP67/IK10 rated protection

## Required tools and parts

The following tools and parts are required for wheel-imaging camera installation:

- T10 Torx key wrench (included)
- 7 mm wrench or socket wrench
- 3 mm Hex key wrench
- Center punch
- Drill
  - 4.8 mm (3/16 in.) drill bit
  - 22.2 mm (7/8 in.) hole saw or stepping drill bit
- Tie wraps for securing cable
- Additional grommets

## Wheel-imaging camera location

Wheel-imaging cameras are either side-mounted on the rear quarter panel or trunk-mounted.

**NOTE:** If you are installing two wheel-imaging cameras, ensure that they are mounted symmetrically on both sides of the vehicle.

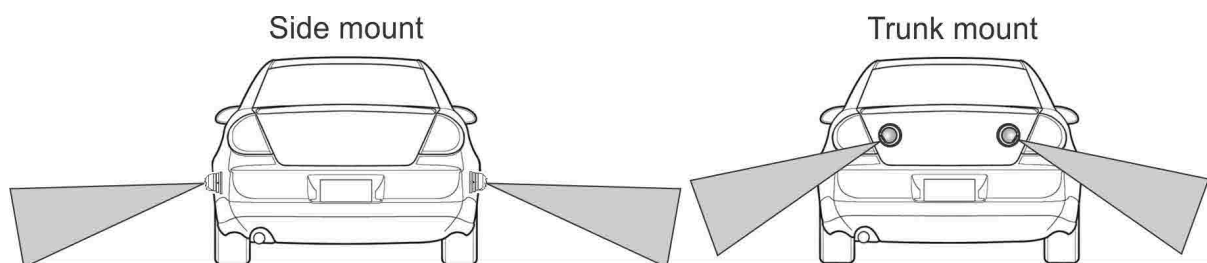

The best choice of installation location generally depends on the vehicle make and model. When selecting a location, it is important to consider ease of installation, aesthetics, and the long-term survivability of the camera. Use the following information when deciding the best installation location.

### Side mount

- This is the preferred location because the wheel-imaging cameras will be closer to the parked vehicle's wheels and they will appear larger in the image.
- You will need to attach the camera to the vehicle using the provided bolts. Ensure that you can access the back of the vehicle panel (usually done by removing the tail light assembly or trunk liner).
- To avoid road grime and rocks kicked up by the tires, select a location that is at or above the top of the wheel well.
- Ensure that the cameras can be mounted symmetrically. Note the location of the vehicle's fuel port and the range of motion of any sliding doors.

### Trunk mount

- Mounting may be easier because you do not need to access the side panel through the tail light assembly or trunk liner.
- Repeated opening and closing of the trunk puts stress on the camera cables.
- This installation type may not be suitable for vehicles with swinging rear doors.
- To avoid damage in a collision, cameras should not extend past the vehicle bumper. Do not install cameras on the vehicle bumper.

## Drilling the mounting and cabling holes for your wheel-imaging camera

When you have selected the location for the wheel-imaging cameras, drill holes for mounting the camera and for passing the camera cable.

### What you should know

- Three 4.8 mm (3/16 in.) holes are required for mounting the camera.
- One 22.2 mm (7/8 in.) hole is required to pass the camera cable and install the camera cable grommet.

#### To drill the mounting holes:

- 1 Access the back of the panel you are mounting the camera on.
  - For side-mount installations, ensure that you can access the inside of the vehicle panel. Ensure that nothing will be damaged when you drill the mounting holes. You may also need to remove the liners from inside the trunk and drill an additional 22.2 mm (7/8 in.) hole in the liner to pass the camera cable.
  - For trunk-mount installations, remove any liners inside the trunk lid. Ensure that nothing will be damaged when you drill the mounting holes.

## 2 Mark the mounting holes and cable hole.

- a) A paper template is included with the camera hardware. Tape the template to the installation location on the vehicle.

**IMPORTANT:** Make sure one of the mounting holes is at the top.

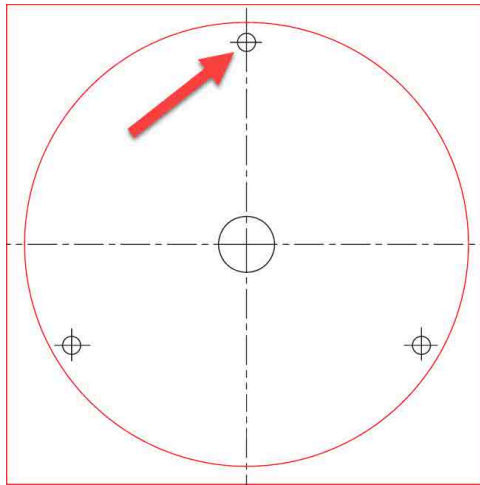

- b) Verify that there are no obstacles, wires, or braces that will prevent the installation of the camera.
- c) Using a center punch, mark the three mounting holes and cable penetration.

## 3 Drill the mounting holes using a 4.8 mm (3/16 in.) drill bit.

## 4 Drill the 22.2 mm (7/8 in.) cable penetration.

For cable penetrations, you can use a stepping drill bit or you can use a fine-toothed hole saw designed for vehicle body panels which is depth-regulated and includes a pilot drill bit.

## Installing a wheel-imaging camera

After you have drilled the mounting holes, you can mount the wheel-imaging camera using the supplied hardware.

### To install the wheel-imaging camera:

- 1 Run the cut end of the 10 meter iX PoE cable from the trunk unit to the outside of the vehicle, through the camera cable hole.

**NOTE:** If you drill any additional holes to pass the cable, install grommets to protect the cable.

- 2 Cut the excess cable.

### NOTE:

- Before making the cut, make sure that the iX connector can still reach its port on the Aux PoE expansion module.
- Leave enough cable so that you can comfortably create the RJ45 connection in later steps.

- 3 Slide the cable connector gland onto the end of the cable.

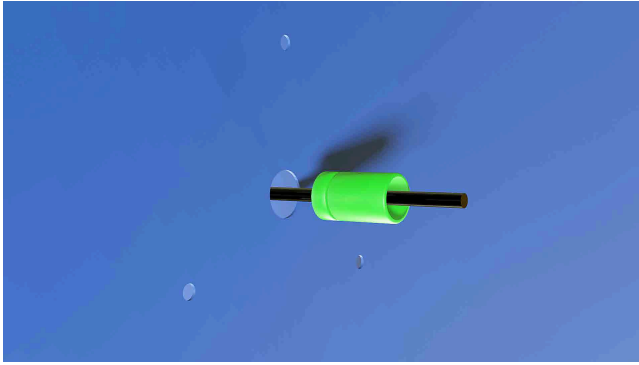

- 4 Terminate the camera cable. Arrange the conductors according to the EIA-T568B standard. For more information, see [Conductor arrangements for SharpZ3 cameras](#) on page 42.



- 5 Connect the RJ45 plug to the camera connector.

**IMPORTANT:** Ensure that the tab on the RJ45 plug locks into place.

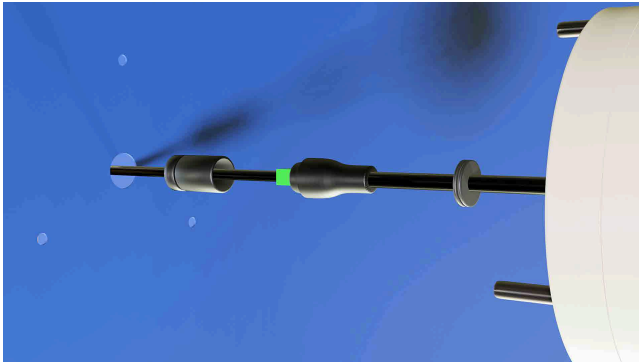

- 6 Slide the cable connector gland over the RJ45 plug and rotate the front of the connector gland ½ turn.

**WARNING:** Do not tighten the constrictor ring at the back of the cable connector gland yet. You must first tighten the front of the cable connector gland highlighted in this image.

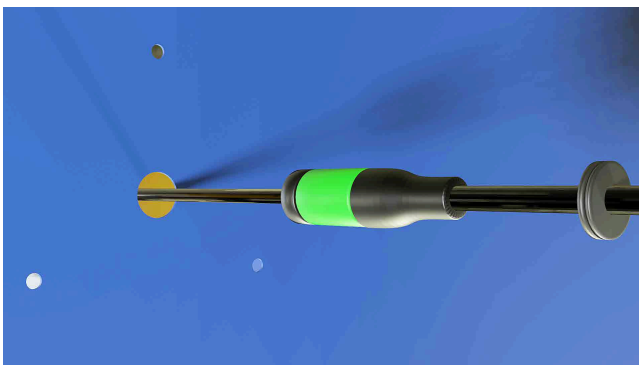

- 7 To create a waterproof connection, hand-tighten the constrictor ring at the end of the cable connector gland.

**WARNING:** Do not try to connect or disconnect the cable while the constrictor ring is tightened.

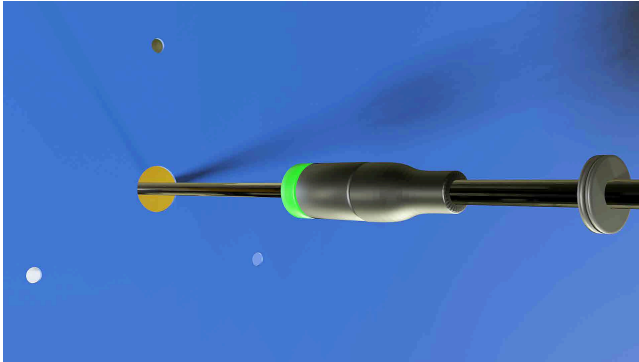

- 8 Push the cable connector through the hole and install the grommet.

**TIP:** To reduce vibration noise, secure the connector with tie wraps.

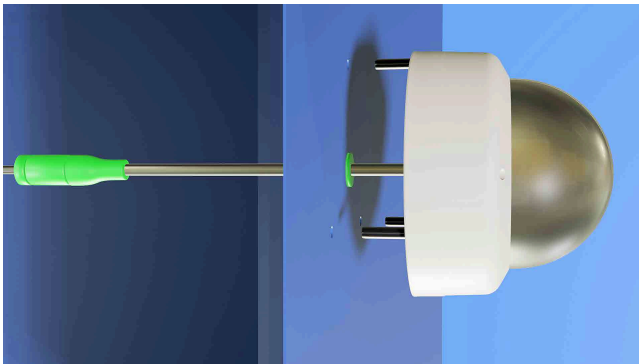

- 9 Remove the three Torx-head screws from the camera body using the provided key wrench.

- 10 Separate the camera dome from the camera base.

**NOTE:** The camera dome is connected to the camera base by a securing strap. You can let the dome hang freely while you install the camera base.

- 11 Insert the provided mounting bolts through the camera base and through the vehicle body panel. To ensure proper water drainage, install the base with the red on the top.



12 Attach the camera using the provided nuts and washers.

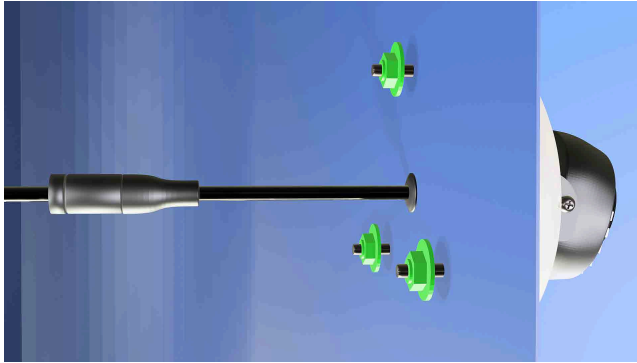

13 Connect the wheel imaging camera cable to the Aux PoE expansion module. For more information, see [Aux PoE expansion module connections](#) on page 50.

14 Log on to the Sharp Portal.

15 Associate the wheel-imaging camera with a SharpZ3 camera. For more information, see [Associating wheel-imaging cameras with SharpZ3 camera units](#) on page 147

16 Open the *Camera feeds* page, and monitor the feed from the wheel-imaging camera.

17 Aim the camera for a side mount or trunk mount installation.

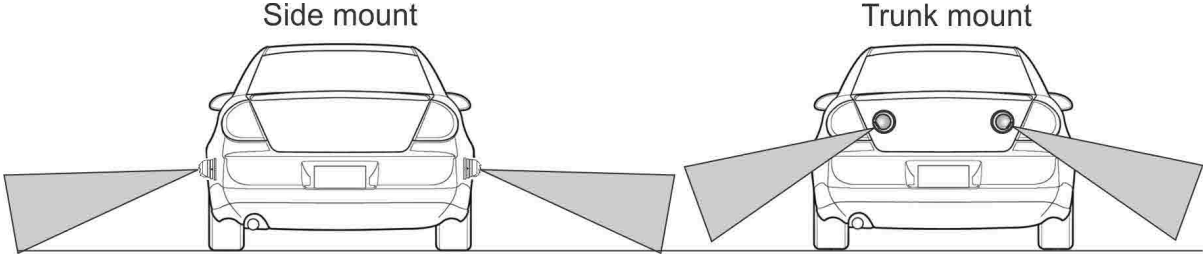

You can adjust three axes of rotation.



Make sure that the arrow is pointing up

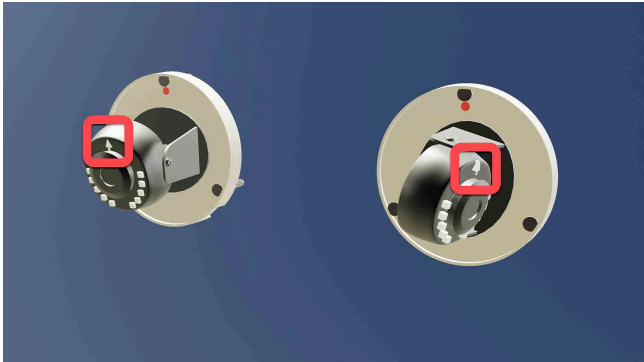

18 Attach the dome to the camera body and secure it using the three Torx-head screws.



19 Complete the installation.

- Replace all tail light assemblies and trunk liners that were removed for the installation.
- Secure the cable using tie wraps.

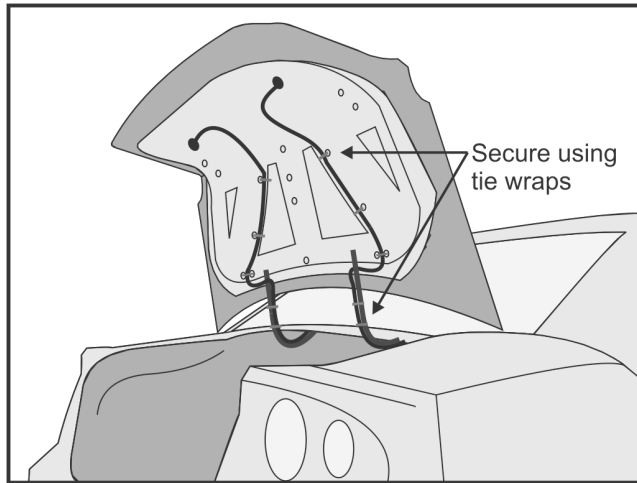



## About the AutoVu™ car camera switch

The AutoVu™ car camera switch is an optional hardware switch module that is installed in a patrol vehicle. The car switch provides manual controls to enable right-side or left-side SharpZ3 cameras.

When the AutoVu™ car camera switch is installed in a patrol vehicle, it removes the need for the operator to control the cameras using the Genetec Patroller™ control buttons. This reduces the distraction associated with using electronic devices while driving.

The device features toggle switches for the right and left cameras as well as LED lights to inform the driver of the current camera activation (red) and to show system power (blue).

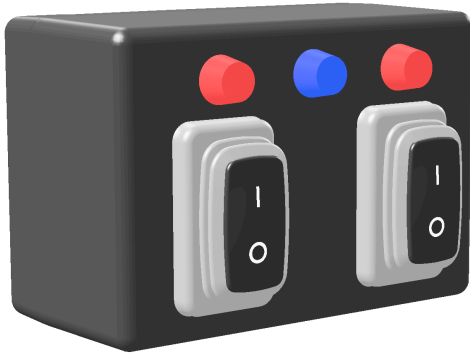

### AutoVu™ car camera switch wiring

To control SharpZ3 camera selection using the AutoVu™ car camera switch, you must connect the switch to the inputs of the base unit.

#### Important information

- The blue and pink wires of the cable are not used in a car camera switch installation. Trim these wires so that they do not interfere with the installation.
- Two 24 AWG jumper wires (shown in black) are required, but are not provided with the kit.

Connect the wires to the base unit as shown in the following wiring diagram:

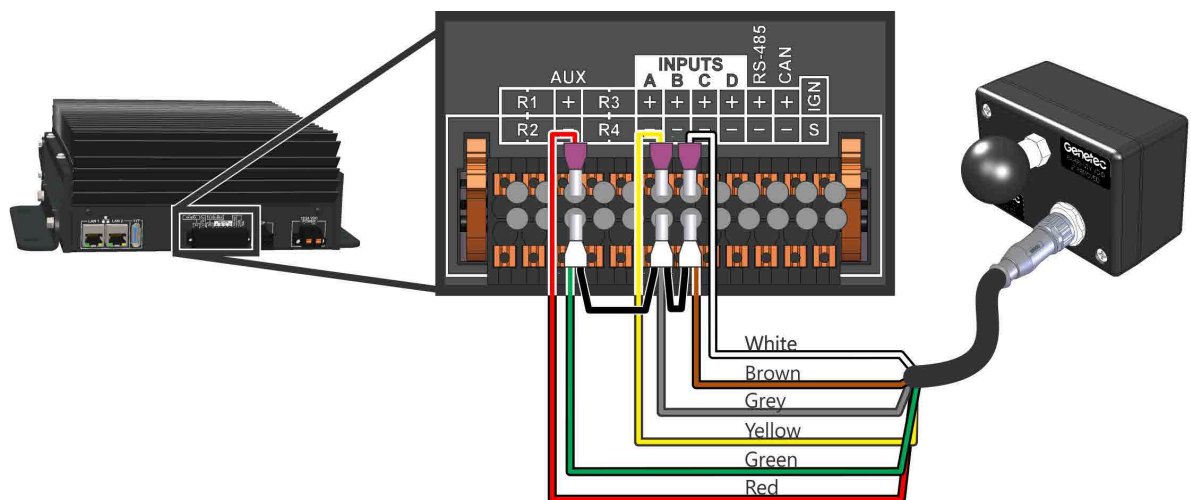

## Mounting the AutoVu™ car camera switch

To control SharpZ3 camera selection using the AutoVu™ car camera switch, you must mount the switch in an accessible location in the patrol vehicle.

**To mount the AutoVu™ car camera switch:**

- 1 Decide on a mounting location.

**NOTE:**

- The switch can be installed anywhere in the patrol vehicle that is safely within reach of the driver. For vehicles that include an in-vehicle computer, the mounting arm usually provides a convenient mounting location.
- If the supplied mounting accessories are not appropriate for your selected mounting location, you can use any components from RAM® Mounts that are compatible with the 1-inch mounting ball on the car switch.

- 2 Run the car switch cable from the mounting location to the base unit.

**NOTE:** The pigtail end of the cable is connected to the base unit and the cable connector connects to the car switch.

- 3 Assemble the supplied mounting accessories according to the instructions included with the hardware.

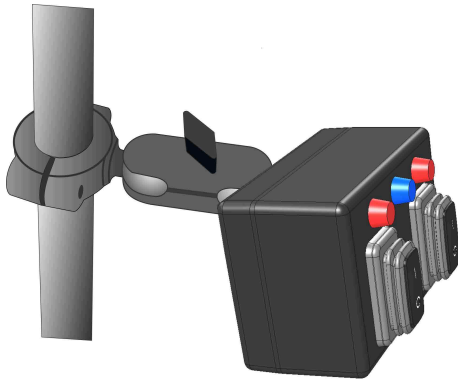

# In-vehicle computer installation

This section includes the following topics:

- ["ToughPad computer installation"](#) on page 109

## ToughPad computer installation

To view license plate reads inside the patrol vehicle, you must install an in-vehicle computer. SharpZ3 systems generally include a Panasonic ToughPad.

The tablet computer's power supply comes with cigarette wiring cabling which should be hardwired to the base unit's auxiliary 8A Max relay. This should be sufficient for one computer connection. The power supply is already fused; no additional fuse is required.

### Installing the ToughPad base mount

Depending on the type of vehicle the ToughPad mount is being installed in, you might need to install a universal base mount, or a base mount that is designed for the vehicle.

#### What you should know

Use these steps to install the following hardware:

- **Base mount:** RAM-VB-109-3U (Genetec part number: AU-H-RAMSWING)

**NOTE:** For this example, we are using the universal base mount.

- **Lower pole:** RAM-VP-TBF12U (Genetec part number: AU-H-RAMPOLEBOT12)

**NOTE:** The lower pole is always shipped with the ToughPad mount hardware, however, the lower pole is only required if you are installing the universal base mount. If you are using a custom base mount, a lower pole is fused to the base mount.

Refer to the following diagram when installing the seat base:

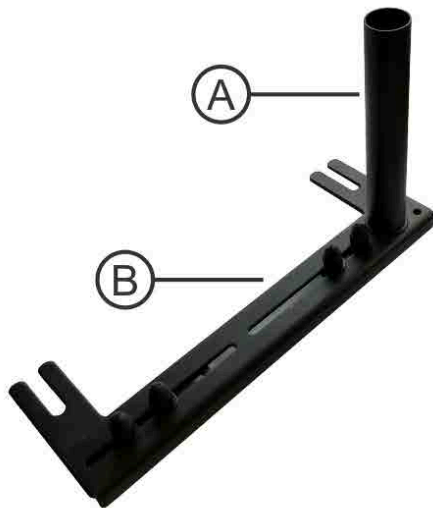

	Component
A	Lower pole
B	Universal base mount

#### To install the ToughPad base mount:

- 1 Assemble and install the base mount using the manufacturer's instructions.

- 2 If the base mount you are installing includes a separate lower pole (A), attach it to the base mount using the manufacturer's instructions.

## Assembling the tele-pole and lower swing arm

The tele-pole is connected to the lower swing arm and is installed on the base mount.

### What you should know

Use these steps to install the following hardware:

- **Tele-pole:** RAM-VP-TTM12U (Genetec part number: AU-H-RAMPOLETOP12)
- **Swing arm:** RAM-VB-109-3U (Genetec part number: AU-H-RAMSWING)

Refer to the following diagram when assembling the tele-pole:

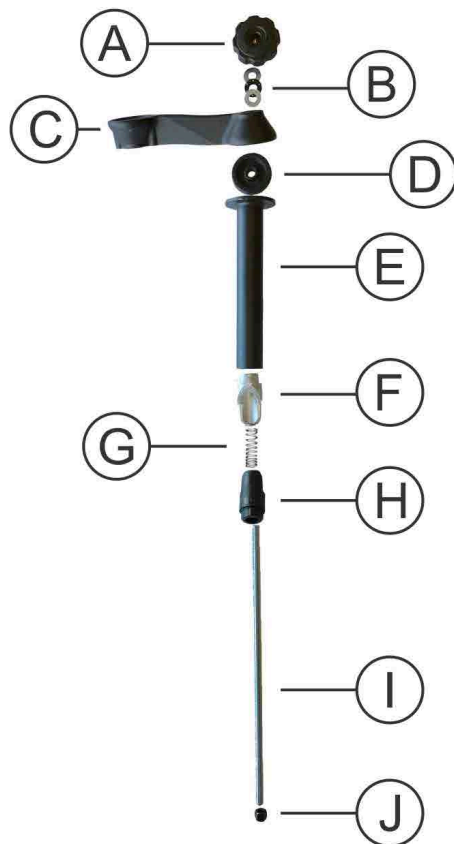

	Component
A	Plastic knob
B	Thrust washer assembly: <ul style="list-style-type: none"> <li>• 2 x flat washers</li> <li>• Ball bearing washers</li> </ul>
C	Swing arm
D	Nylon washer

	Component
E	Upper tube
F	Aluminum wedge
G	Spring
H	Plastic wedge
I	Threaded rod
J	Hex lock nut

**NOTE:** The hardware provided with the swing arm is not required. This includes an additional knob (A), thrust washer assembly (B), and nylon washer (D).

**To assemble the tele-pole:**

- 1 Screw the lock nut (J) onto the threaded rod (I) using a wrench. The rod should protrude through the nut by about 0.6 cm (1/4").

**TIP:** For a better grip, you can use pliers to hold the center of the bolt.

- 2 Slide the plastic wedge (H) onto the rod. The flat part of the wedge should touch the lock nut.
- 3 Slide the spring (G) onto the rod.
- 4 Invert the metal wedge (F) and slide it onto the rod. The angled side of the two wedges should touch.
- 5 Slide the upper tube (E) onto the rod. The flared side of the tube should point away from the wedges.
- 6 Slide a nylon washer (D) onto the rod.
- 7 Slide the lower swing arm (C) onto the rod as shown in the diagram.

**NOTE:** The manufacturer's name "RAM" must be facing upward.

- 8 Create a thrust washer assembly (B) using a ball bearing washer between two flat washers.



- 9 Slide the thrust washer assembly onto the rod.
- 10 Screw the plastic knob (A) onto the top of the rod. Do not tighten the knob.
- 11 Slide the tele-pole assembly into the lower pole which is attached to the base mount.
- 12 Tighten the plastic knob to secure tele-pole to the base mount.

## Assembling the tilt-pivot head

After the tele-pole is assembled, you can attach the tilt-pivot head and upper swing arm.

### What you should know

Use these steps to install the following hardware:

- **Tilt-pivot head:** RAM-VB-TNT90-1 (Genetec part number: AU-H-RAMTNT90)
- **Swing arm:** RAM-VB-109-3U (Genetec part number: AU-H-RAMSWING)

Refer to the following diagram when assembling the tilt-pivot head:

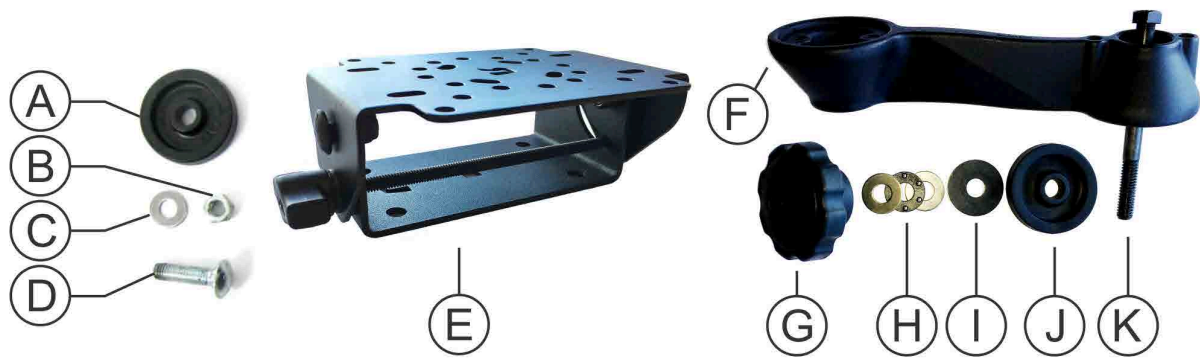

	Component
A	Nylon washer
B	Lock nut
C	Flat washer
D	Carriage bolt
E	Tilt-pivot head assembly
F	Swing arm
G	Plastic knob
H	Thrust washer assembly: <ul style="list-style-type: none"> <li>• 2 x flat washers</li> <li>• Ball bearing washers</li> </ul>
I	1 ¼" flat washer
J	Nylon washer
K	Hex bolt

**To assemble the tilt-pivot head:**

- 1 Rotate the tilt-pivot assembly (E) enough to place the carriage bolt (D) through the square opening from the bottom.

- 2 Slide the nylon washer (A) onto the carriage bolt with the flat side of the washer touching the tilt-pivot assembly.

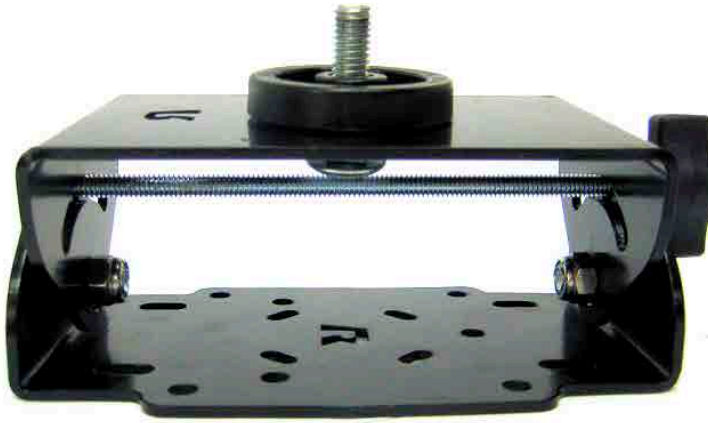



- 3 Place the swing arm (F) over the carriage bolt and attach it using the flat washer (C) and lock nut (B).

**NOTE:** The manufacturer's name "RAM" must be facing downward. When you invert the finished assembly, "RAM" will be facing upward.



The assembled tilt-pivot head should look like this:



**Connect the tilt-pivot head to the tele-pole:**

Refer to the following diagram when mounting the tilt-pivot head onto the tele-pole:



- 4 Sandwich the nylon washer (J) between the upper swing arm (F) and the lower swing arm (L).
- 5 Insert the hex bolt (K) downward, connecting the upper and lower swing arms.
- 6 Slide the 1 ¼" flat washer (I) onto the hex bolt.
- 7 Create a thrust washer assembly (H) using a ball bearing washer between two flat washers and slide the assembly onto the hex bolt.



- 8 Screw the plastic knob (G) onto the hex bolt to secure the swing arm assembly.

## Attaching the tablet mount to the tilt-pivot head

After the tilt-pivot head is attached to the tele-pole, you can attach the tablet mount to the tilt-pivot head.

### Before you begin

Ensure that you have all of the required hardware:

- Tablet mount
- Tilt-pivot head
- 4 x ¾" flat head screws
- 4 x serrated flange nuts

### What you should know

You must connect the tablet mount to the tilt-pivot head as shown before connecting the keyboard tray to the tablet mount.

**To attach the tablet mount to the tilt-pivot head:**

- 1 The tablet mount (A) and the tilt-pivot head should both be able to tilt towards the user. Orient the tablet mount and the tilt-pivot head as shown.

**NOTE:** The adjustment knob on the tilt-pivot head might be on either side depending on how it was assembled by the manufacturer.

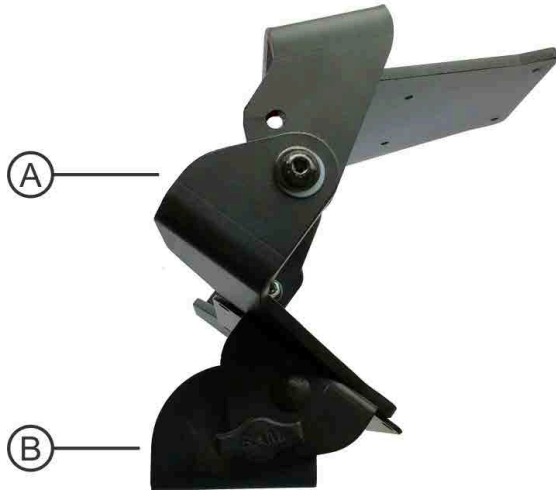

- 2 Connect the tablet mount (B) to the tilt-pivot head using the four  $\frac{3}{4}$ " flat head screws and serrated flange nuts in the mounting holes (C) shown in the following image.

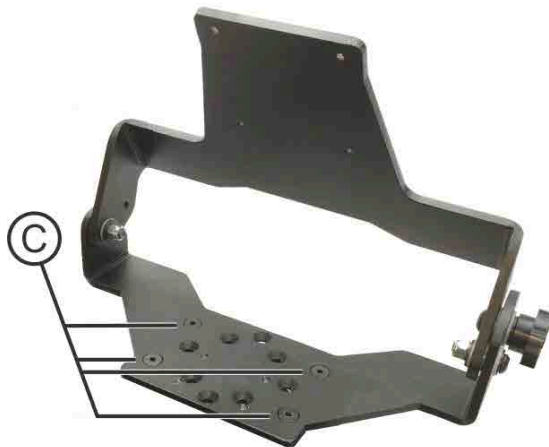

## Attaching the ToughPad dock and keyboard tray to the tablet mount

After the table mount is attached to the tilt-pivot head, you can attach the ToughPad dock and keyboard tray to the tablet mount.

### What you should know

Use these steps to install the following hardware:

- **ToughPad dock:** AS7.P001.100 (Genetec part number: AU-H-PANADKSTG1)
- **Keyboard tray:** AS7.C100.002 (Genetec part number: AU-H-PANAKEYTRAY)
- 4 x  $\frac{3}{8}$ " flat head screws

**To attach the ToughPad dock and keyboard tray to the keyboard mount:**

- 1 Connect the mounting bracket (A) to the tablet mount (B) as shown using the screws that are pre-fastened to the tablet mount.



- 2 On the back of the ToughPad dock, set the *EXT/INT ANT* switch (C) to *INT*.

**IMPORTANT:** Do not use the *EXT* setting. Doing so disables the system's networking capability and the system does not function.



- 3 Attach the ToughPad dock (D) to the mounting bracket (E) as shown using the screws that are pre-fastened to the mounting bracket.

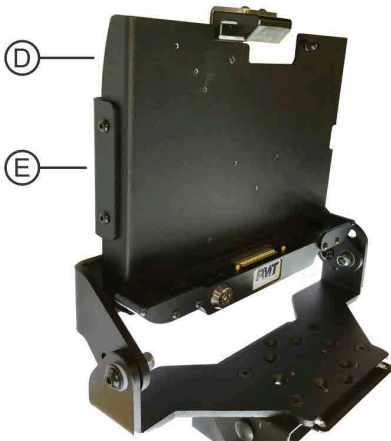

- Attach the keyboard tray (F) to the tablet mount as shown using the four 3/8" flat-head screws (G) that are shipped with the keyboard tray.

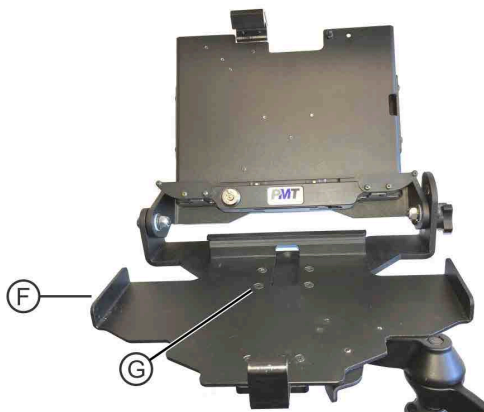

## About powering the in-vehicle computer

You must use the 8A MAX relay on the base unit to control the power to the in-vehicle computer. This way, the computer receives power only when the ignition is on.

You must power the in-vehicle computer through the base unit auxiliary 8A MAX relay. This way, the tablet computer and the base unit both react to the vehicle ignition signal, after a configurable delay. The tablet then runs on its own battery for a duration configurable in Windows.

The following diagram shows a typical installation in which power for the in-vehicle computer is controlled by the base unit relay:

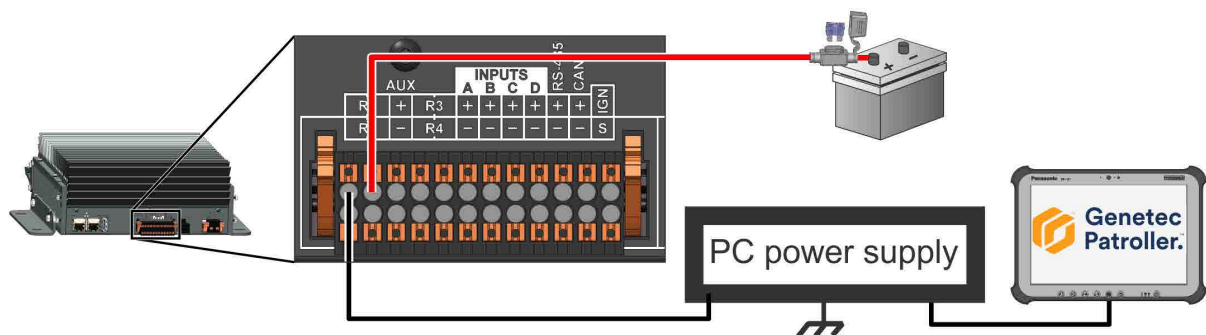

# Introduction to the Sharp portal

This section includes the following topics:

- ["About the Sharp Portal"](#) on page 120
- ["Logging on to the Sharp Portal"](#) on page 121
- ["Changing your logon password in the Sharp Portal"](#) on page 125
- ["Sharp Portal interface overview"](#) on page 126
- ["Viewing camera feeds"](#) on page 128
- ["SharpZ3 hardware inventory"](#) on page 130
- ["Rebooting the SharpZ3 ALPR module"](#) on page 131
- ["Synchronizing the SharpZ3 clock"](#) on page 132
- ["Configuring battery monitoring"](#) on page 133

# About the Sharp Portal

The Sharp Portal is a web-based administration tool used to configure Sharp cameras for AutoVu™ systems. From a web browser, you log on to a specific IP address (or the Sharp name in certain cases) that corresponds to the Sharp you want to configure. When you log on, you can configure options such as selecting the ALPR context (for example, Alabama, Oregon, Quebec), selecting the read strategy (for example, fast moving or slow moving or slow moving vehicles), viewing the Sharp's live video feed, and more.

**NOTE:** On a SharpZ3 unit that includes a four-camera ALPR module, each set of two cameras is configured in a separate Sharp Portal which is available from a link on the *Maintenance* page.

The screenshot displays the AutoVu Sharp web portal interface. The top navigation bar includes 'Dashboard', 'Configuration', 'Diagnostics', and 'Help'. The user is logged in as 'Admin' in 'English' and can 'Log out'. The left sidebar shows 'Overview', 'Camera feeds' (selected), and 'Inventory'. The main content area is titled 'Camera feeds' and shows a 'Camera unit' dropdown set to 'ALPR camera unit 1'. Below this, there are two video feeds: 'ALPR camera' showing a car at night with license plate 'J97HBD' and 'Context camera' showing a car in a parking lot. A 'Show metadata' link is visible below the ALPR camera feed. The 'Last reads' section shows a candidate 'J97HBD' with a count of 30 and a 'Reset' button. The metadata table is as follows:

Candidate	Vehicle Type
J97HBD	-
Count	Relative Motion: Moving Away
30	Context: Quebec
Reset	Characters Height: 23
	Plate Tilt: -14.0
	Confidence Score: 87
	Lpr Exposure: -
	Context Exposure: -
	Input A: Low
	Input B: Low
	Input C: Low

## Benefits of the Sharp Portal

- **Open Sharp Portals in many tabs:** Web browsers use tab-based browsing, which provides you with a simple way to configure multiple SharpZ3 cameras. You can have many instances of the Sharp Portal open within the same Web browser.
- **Secure connection:** You can log on to the Sharp Portal securely using an HTTPS protocol with SSL encryption.
- **Use Favorites:** You can easily monitor and configure all the SharpZ3 units on your network. For example, if you have multiple SharpZ3 units on your network, you can add them all to your Web browser's Favorites folder, and then rename them (for example, SharpNorthParkingLot) for quick configuration and maintenance.

# Logging on to the Sharp Portal

To configure SharpZ3 cameras, you must log on to the Sharp Portal.

## Before you begin

- You need to know the IP address or name of the SharpZ3 camera you want to connect to:
  - SharpZ3 name:** You can find the SharpZ3 name (for example, SharpZ312345) on the label on the back of the unit.
  - Fallback IP address:** The fallback IP address is 192.168.10.100. The fallback IP address is only available if the camera is in DHCP mode (default). After camera startup, the camera searches for a DHCP server. If no DHCP server is present on the network after two minutes, the fallback IP address is made available.

## What you should know

- You can access the Sharp Portal using the following browsers:
  - Microsoft Edge version 41 and later
  - Google Chrome version 46 and later
- To ensure that camera feeds are displayed correctly, only open one instance of the Sharp Portal at a time.

### To log on to the Sharp Portal:

- 1 Open your Web browser, and go to `https://<SharpZ3 name or IP address>`.

A two-camera ALPR module is configured through one Sharp Portal; a four-camera ALPR module is configured through two Sharp Portals.

- Sharp Portal 1 (camera ports 1 and 2):** <http://192.168.10.1/>
- Sharp Portal 2 (camera ports 3 and 4):** <http://192.168.10.2/>

## Sharp Portal 1

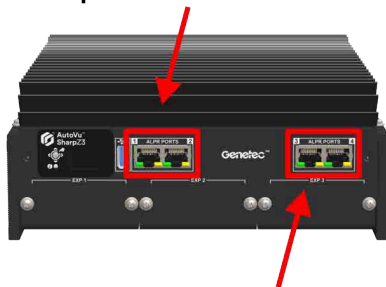

## Sharp Portal 2

- 2 Enter the **Username** and **Password**.
  - If you have already logged on and changed the default password, enter your **Username** and **Password** and click **Connect**.
  - If this is the first time you are logging on to the Sharp Portal for this unit, enter the default credentials
    - Username:** admin
    - Password:** Genetec



3 Click **Connect**.

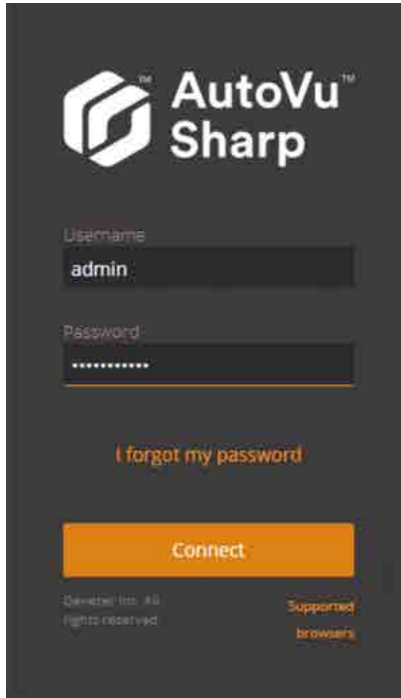

4 Select the power line frequency that corresponds to the installation location.



- **60 Hz:** Generally used in North America and South America
- **50 Hz:** Generally used in Africa, Australia, Asia, and Europe

**NOTE:** For more information on the power line frequency used in your installation location, [click here](#).

- 5 Click **Enter context name** and select which regional context to use.

**NOTE:** You can change the regional context when you [configure analytics for the SharpZ3](#).

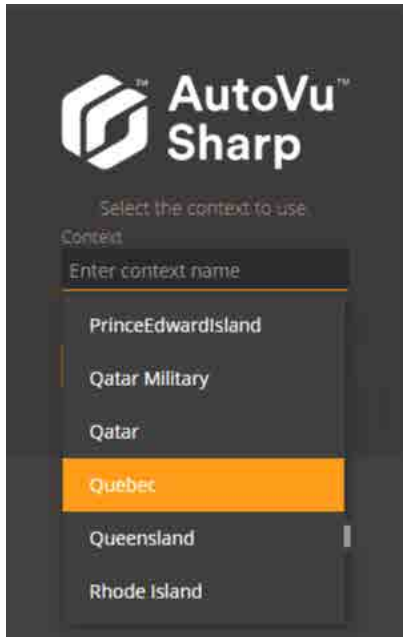

- 6 Click **Next**.
- 7 Enter and confirm a new password.



**NOTE:** You cannot modify the username.

- 8 Click **Next**.
- 9 You are redirected to the logon page. Enter the **Username** and new **Password**, then click **Connect**.

10 Click **Connect**.

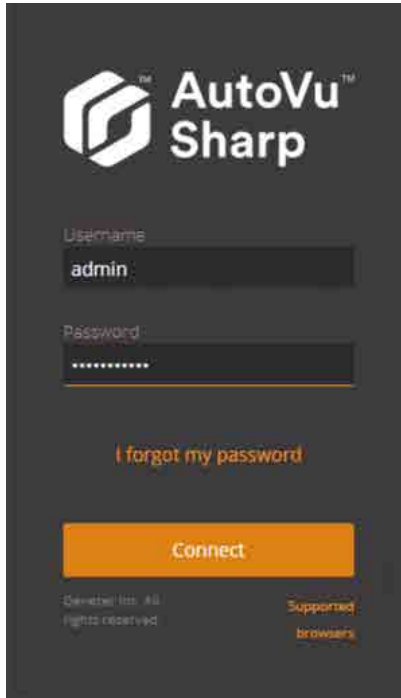

After successfully logging on, the Sharp Portal opens to the **Overview** page of the **Dashboard** menu.

# Changing your logon password in the Sharp Portal

---

For security reasons, you might need to change the logon password for the Sharp unit. You can do this in the Sharp Portal.

## What you should know

A two-camera ALPR module is configured through one Sharp Portal; a four-camera ALPR module is configured through two Sharp Portals.

- **Sharp Portal 1 (camera ports 1 and 2):** <http://192.168.10.1/>
- **Sharp Portal 2 (camera ports 3 and 4):** <http://192.168.10.2/>

## Sharp Portal 1

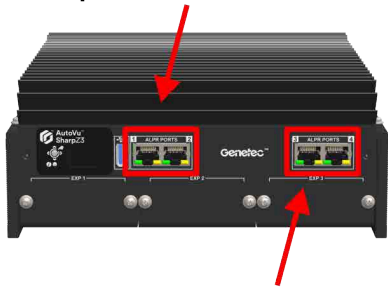

## Sharp Portal 2

### To change your password:

- 1 Log on to the Sharp Portal.
- 2 From the **Configuration** menu, select the **Security** page.
- 3 In the **Access** section, click **Modify password**.
- 4 Enter your old password, then enter and confirm your new password.
- 5 Click **Apply**.

# Sharp Portal interface overview

To familiarize yourself with the Sharp Portal, you can take a tour of the main areas of the user interface.

The screenshot shows the Sharp Portal interface for a device named SharpZ300024. The interface is dark-themed and includes a navigation menu on the left with options: Overview, Camera feeds, and Inventory. The main content area is divided into several sections:

- Overview:** Displays device details for SharpZ300024, including Serial number (G1214800091117001A), License (Valid), Inputs (A: Low, B: Low, C: Low, D: Low), Outputs (1: Low, 2: Low, 3: Low, 4: Low), MAC address (00-50-56-99-5E-30), Type (SharpZ3), Illuminator (720 nm, StandardRange), Platform (19.063.1), Version (13.0.334.0), and Camera details (Context Camera, 640x480, -; Lpr Camera, 102x38, -).
- Connectivity:** Shows IP addresses (10.2.0.75, 2607:fad8:9:209:1352:9aa5:7b9f:2130, 2607:fad8:9:209:a122:1f69:b7b3:2b06) and Internet status (Connected).
- Video streams:** Indicates no active video streams.
- Storage and usage:** Displays storage usage for Drive C (24 KiB / 49.4 GiB), Drive D (4.8 GiB / 6 GiB), and Drive E (40 GiB / 49.4 GiB).
- CPU (Total):** Shows 16% usage.
- Last activities:** Lists recent events such as Unit rebooted (7 days ago) and Software restarted (18 hours ago).

Callout letters A-F point to the following elements:

- A:** Browser address bar showing the URL `https://10.2.0.75`.
- B:** Navigation menu items: Dashboard, Configuration, Diagnostics, Help.
- C:** User profile, language selection (English), and Log out button.
- D:** Left-hand navigation menu items: Overview, Camera feeds, Inventory.
- E:** Connectivity section.
- F:** CPU usage section.

<b>A</b>	Sharp Portal address	Type the SharpZ3 name or the IP address. The format is <code>https://Sharp12345</code> or <code>https://192.168.10.100</code>
<b>B</b>	Menu	Shows the main categories of the Sharp Portal.
<b>C</b>	Current user	Shows the current user, language selection, and log out command.
<b>D</b>	Pages	Shows the available pages for the selected portal menu.

---

E	Sections	Shows the available information, status, or settings for the selected portal page.
F	Additional information	Orange text indicates that the text is clickable. This can indicate a hyperlink, can trigger actions, or can display additional information.

---

## Viewing camera feeds

---

You can use the camera feed to test and align Sharp cameras.

**To view the Sharp unit camera feed:**

- 1 [Log on to the Sharp Portal](#).
- 2 From the **Dashboard** menu, select the *Camera feeds* page.

The *Camera feeds* page displays the feeds from the selected Sharp unit and recent license plate reads from the unit.

The following options are available in the *Camera feeds* page:

- **Camera unit:** Select which Sharp camera or auxiliary camera to view.
- **Cameras:** Displays the resolution and the lens focal range available for cameras connected to the SharpZ3 unit.
- **Overlays:**
  - **Crosshairs:** Select this option to display crosshairs in the ALPR or context camera window.
  - **Bounding box:** Select this option to display the yellow bounding box around detected plates in the ALPR camera window.
- **Record:** Click the **Record** button to capture a series of context and ALPR images directly from the *Camera feeds* window and save them to your computer as a .zip file for debugging purposes.

**NOTE:**

- Using the **Record** feature increases CPU usage.
- To use this feature, you cannot use the camera's auto-generated certificate. You must install a self-signed certificate that includes the IP address of the camera.

- 3 From the **Camera unit** menu, select a camera group to view its live feeds.

The screenshot displays the AutoVu Sharp portal interface. The top navigation bar includes 'Dashboard', 'Configuration', 'Diagnostics', and 'Help'. The user is logged in as 'Admin' in 'English' and can 'Log out'. The left sidebar contains 'Overview', 'Camera feeds', and 'Inventory'. The main content area is titled 'Camera feeds' and shows a dropdown menu for 'Camera unit' set to 'ALPR camera unit 1'. Below this, there are two video feeds: 'ALPR camera' showing a car with license plate 'J97HBD' and 'Context camera' showing a wider view of the road. A 'Videos' section below the feeds shows 'Last reads' with a table of metadata for the candidate 'J97HBD'.

Candidate	Vehicle Type
J97HBD	-
Count	Relative Motion: Moving Away
30	Context: Quebec
Reset	Characters Height: 23
	Plate Tilt: -14.0
	Confidence Score: 87
	Lpr Exposure: -
	Context Exposure: -
	Input A: Low
	Input B: Low
	Input C: Low

## After you finish

To reduce network bandwidth, after you have finished viewing the camera feeds, select **No camera** from the **Cameras** menu, or navigate to a different page of the Sharp Portal.

## Related Topics

[Camera alignment](#) on page 84



## SharpZ3 hardware inventory

The **Dashboard > Inventory** page in the Sharp Portal displays information on SharpZ3 system hardware.

The *Inventory* page is available from the **Dashboard** menu. The page displays the status of the hardware components of the system and allows you to identify camera units by blinking their LEDs. You can see the installed expansion modules and available expansion module slots.

**NOTE:** To see the most recent information in the *Inventory* page, you must refresh the web page.

The *Inventory* page provides the following information:

- **Module:** Displays the name of the component.
- **Version:** Displays the component's firmware version.
- **Identification:** Displays a unique identifier of the component, such as its name or serial number.  
**NOTE:** The serial number is also printed on the component sticker.
- **Status:** Displays the health status of the component.
- **Blink LED:** Blinks the LED on SharpZ3 cameras or the SharpZ3 base unit.

The screenshot shows the 'Inventory' page in the AutoVu Sharp portal. The page has a dark theme and a navigation sidebar on the left with options for Overview, Camera feeds, and Inventory. The main content area displays a table of hardware components. The table has columns for Module, Version, Identification, and Status. A 'Blink LED' button is visible next to the 'LPR module A1' row.

Module	Version	Identification	Status
Rack A	1.2.3	G1404100119520011A	Normal
I/O module A0			Normal
Input A01			Normal
Output A01			Normal
Input A02			Normal
Output A02			Normal
Input A03			Normal
Output A03			Normal
Input A04			Normal
Output A04			Normal
LPR module A1	13.0.0.0	SHARPY001234	Normal
Camera unit A11	1.2.3	G1404200119520013A	Normal
Camera unit A12	1.2.3	G1404200119520013B	Normal
Empty A2			Disconnected
Navigation module A5	1.2.3		Normal

# Rebooting the SharpZ3 ALPR module

---

Certain configuration procedures require you to reboot the SharpZ3 ALPR module. You can do this from the Sharp Portal.

## What you should know

- Following these steps will reboot the SharpZ3 base unit as well as the two camera ports associated with the Sharp Portal. To reboot the entire SharpZ3 system, you must power cycle the base unit.
- A two-camera ALPR module is configured through one Sharp Portal; a four-camera ALPR module is configured through two Sharp Portals.
  - **Sharp Portal 1 (camera ports 1 and 2):** <http://192.168.10.1/>
  - **Sharp Portal 2 (camera ports 3 and 4):** <http://192.168.10.2/>

## Sharp Portal 1

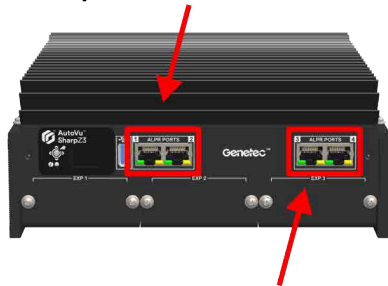

## Sharp Portal 2

### To reboot the SharpZ3 system:

- 1 [Log on to the Sharp Portal.](#)
- 2 From the **Configuration** menu, select the *Maintenance* page.
- 3 Click the **Reboot unit** button.  
The connection to the Sharp Portal is momentarily lost.
- 4 Wait approximately 2 minutes to allow the system to reboot and the Sharp Portal to restart.

# Synchronizing the SharpZ3 clock

---

You can configure the SharpZ3 to synchronize time and date settings with the computer you are using to access the Sharp Portal, or with an NTP server.

## What you should know

By default, the SharpZ3 synchronizes its time and date settings with the active extension defined in the **Configuration > Connectivity > Extension** page. Alternatively, you can manually configure the date and time selection in the **Configuration > General settings > Date and time** page.

### To synchronize the SharpZ3 clock:

- 1 [Log on to the Sharp Portal](#).
- 2 From the **Configuration** menu, select **General settings > Date and time**.
- 3 Select one of the following options:
  - **NTP server:** The camera synchronizes with an NTP server that is typically either a foreign computer or a server within your organization that synchronizes itself with an external NTP server. The latter is recommended if synchronization is crucial to your organization. Click **Server** and enter the URL or IPv4 address of the machine running the NTP server. Click **Test connection** to tests the connection between the camera and the NTP server. The camera synchronizes with the NTP server every hour.
  - **Active extension (Patroller):** If you select **Active extension (Patroller)**, the camera's date and time are synchronized with the Genetec Patroller™ server that the camera is connected to. The camera synchronizes with the server upon connection, then again every 10 minutes.

**NOTE:** If you have not yet configured the active extension (see [Configuring where the SharpZ3 sends its ALPR data](#) on page 152), you can select **Active extension**, and it will be updated when you configure the extension.

**NOTE:** The **Active extension** option displays whichever extension is currently selected for the camera in *Configuration > Extensions*, however, selecting this option has no effect if you are using an extension type other than Patroller (not valid for FTP, HTTP, and so on).

- 4 Click **Save**.

# Configuring battery monitoring

By default, power to the SharpZ3 base unit and connected devices continues to be supplied for 60 seconds after the vehicle engine is turned off. You can configure how power is managed when the system shuts down.

## What you should know

**WARNING:** Configuring incorrect battery monitoring settings can render the unit temporarily unusable or impair the battery.

### To configure battery monitoring:

- 1 [Log on to the Sharp Portal.](#)
- 2 Click **Configuration > General settings > Power options.**
- 3 Click **Show Advanced.**
- 4 Configure **Battery Monitoring** settings.
  - **Turn on voltage:** Input voltage threshold below which the unit does not turn on.
  - **Ignition cut-off delay:** Grace period between ignition cut-off and trunk unit power-down.
  - **Undervoltage:** Input undervoltage threshold that causes a unit shut-off if maintained for a certain time.

**NOTE:** The voltages in the following table are measured at the base unit power connector. Note that there is an approximate 5 -7 V drop between the battery and the base unit power connector.

Parameter	Minimum	Maximum	Default
Turn on voltage	9.5 V	25.5 V	12 V

Parameter	Minimum	Maximum	Default
<b>Ignition cut-off delay</b>	10 seconds	30 minutes	60 seconds
<b>Undervoltage</b>	9 V	25.5 V	10.3 V

**NOTE:**

- The **Turn on voltage** and **Undervoltage** parameters have a precision of 0.1 V. For example, a voltage of 20.789456 V is rounded to 20.7 V.
- The **Ignition cut-off delay** parameter is rounded down to the nearest 10. For example, a cut-off time of 48 seconds is rounded to 40 seconds.

The screenshot shows the AutoVu Sharp Configuration page. The left sidebar contains a navigation menu with the following items: Network, Security, Cameras, Analytics, Connectivity, General settings, Recovery, Date and time, Power options (highlighted), and Maintenance. The main content area is titled "Power options" and includes the following settings:

- Power line frequency:** 60 Hz (selected) and 50 Hz.
- Battery monitoring:** A warning message states: "Battery monitoring is an advanced feature that could severely impair your battery lifetime if not properly set."
- Turn on voltage:** 12 volts.
- Ignition cut-off delay:** 60 seconds.
- Undervoltage:** 10.3 volts.
- Reset battery settings:** A link to reset the settings.

- 5 Click **Save**.

# SharpZ3 camera configuration

This section includes the following topics:

- ["Security configuration in the Sharp Portal"](#) on page 136
- ["About SharpZ3 exposure adjustment"](#) on page 142
- ["Configuring SharpZ3 position and location"](#) on page 145
- ["Associating wheel-imaging cameras with SharpZ3 camera units"](#) on page 147
- ["Configuring SharpZ3 analytics"](#) on page 150
- ["Configuring where the SharpZ3 sends its ALPR data"](#) on page 152
- ["About SharpZ3 network settings"](#) on page 154
- ["Configuring the SharpZ3 FTP extension"](#) on page 158
- ["Configuring the SharpZ3 HTTP/HTTPS extension"](#) on page 161
- ["Configuring Syslog for SharpZ3 log files"](#) on page 165
- ["Importing and exporting settings"](#) on page 166

# Security configuration in the Sharp Portal

---

SharpZ3 cameras must communicate using TLS encryption (HTTPS) using either the certificate that is auto-generated on the SharpZ3, a new self-signed certificate, or a signed certificate from your own public key infrastructure (PKI) or from a Certificate Authority such as VeriSign.

Consider the following:

- The first time you log on to the Sharp Portal, a self-signed certificate is generated and HTTPS is activated by default.
  - You must install the certificate on all machines that communicate with the SharpZ3 camera. This includes the servers hosting the LPR Manager, the Archiver, and all machines that connect to the Sharp Portal
  - You can install multiple certificates and then select a certificate to activate.
- IMPORTANT:** If the current certificate is a signed certificate, deleting the certificate signing request prevents the certificate from being reinstalled.
- To capture context and ALPR images directly from the SharpZ3 using the **Record** button on the *Camera feeds* window of the Sharp Portal, you cannot use the camera's auto-generated certificate. You must install a signed or self-signed certificate that includes the IP address of the camera as the *common name*.
  - If the IP address of the SharpZ3 changes, you must regenerate and reinstall the signed or self-signed certificate.

## Installing the SharpZ3 auto-generated certificate

If the SharpZ3 unit uses its auto-generated certificate for HTTPS communication, you must install the certificate on all machines that communicate with the Sharp unit.

### Before you begin

Read about [how the Sharp Portal must be encrypted](#).

### What you should know

- To capture context and ALPR images directly from the SharpZ3 using the **Record** button on the *Camera feeds* window of the Sharp Portal, you cannot use the camera's auto-generated certificate. You must install a signed or self-signed certificate that includes the IP address of the camera as the *common name*.
- IPv6 static addresses are not supported.

#### To install the auto-generated certificate on a workstation:

- 1 On the machine where you want to register the certificate, log on as an Administrator.
- 2 [Log on to the Sharp Portal](#).
- 3 From the **Configuration** menu, select the *Security* page.
- 4 Click the certificate with the **Friendly name:** *Genetec Portal Auto Generated*.  
The *Certificate details* are displayed.

- Click **Download certificate** and save the certificate file as prompted by your browser.

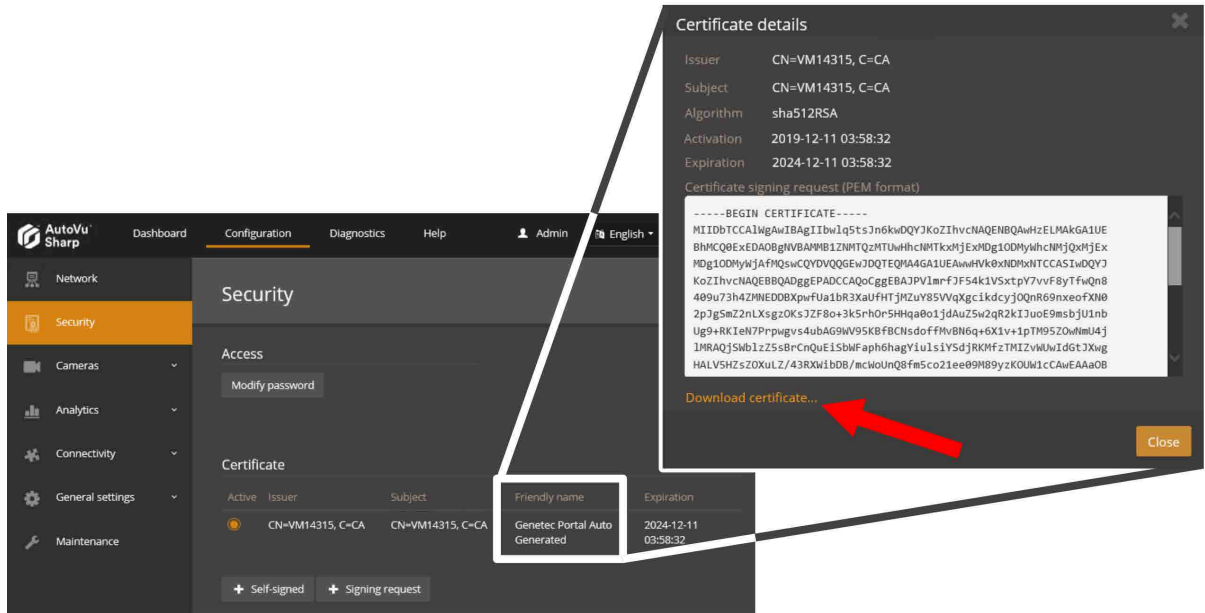

- Double-click the *certificate.cer* file and click **Install Certificate**.
- The *Certificate Import Wizard* prompts you to select a store location. Select **Local Machine** and click **Next**.

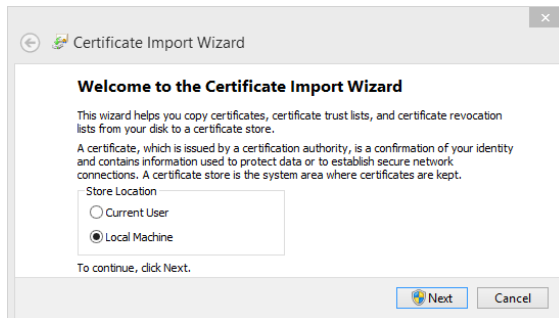

- The wizard prompts you to select the certificate store you want to use. Select **Place all certificates in the following store** and click **Browse**.

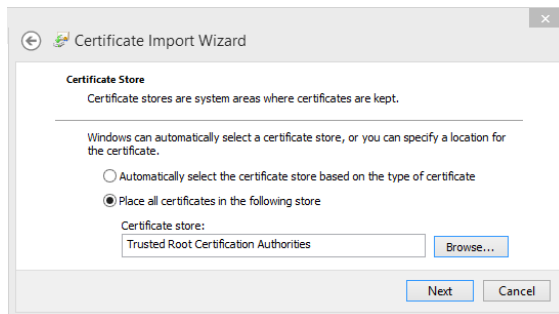



- 9 From the **Select Certificate Store** window, select **Trusted root certification Authorities** and click **OK**.

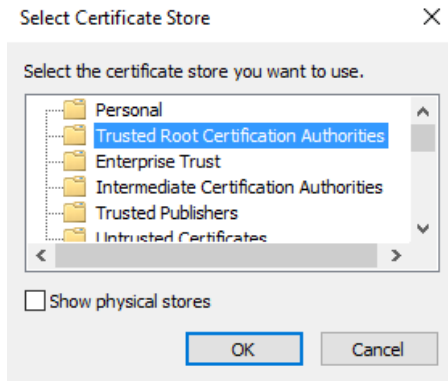

- 10 Click **Next** to continue, and click **Finish** to close the wizard.

The system displays the message: *The import was successful.*

- 11 Close all web browsers and open the Windows Task Manager to ensure that no browser processes are running in the background.
- 12 Log on to the Sharp Portal. You are automatically logged on in HTTPS mode.

A lock icon (  ) in the browser's address bar indicates that you are now logged on to the SharpZ3 with a secure connection.

## Installing a self-signed certificate

If the SharpZ3 unit uses a self-signed certificate for HTTPS communication, you must install the certificate on all machines that communicate with the Sharp unit.

### Before you begin

Read about [how the Sharp Portal must be encrypted](#).

### What you should know

IPv6 static addresses are not supported.

#### To encrypt connection to the Sharp Portal using a self-signed certificate:

- 1 On the machine where you want to register the certificate, log on as an Administrator.
- 2 [Log on to the Sharp Portal](#).
- 3 From the **Configuration** menu, select the *Security* page.
- 4 From the **Certificate** section, select **+ Self-signed**.
- 5 Enter the required information for the certificate and click **OK**.
  - The **Country** field requires a two-letter country code.
  - If you are also using the certificate to connect to the Archiver, the **Sharp's common name** (Sharp's IP address if connecting to the Archiver) defined in the certificate must be the Sharp unit's IP address, not the Sharp name.

The message *Operation succeeded* is displayed and the signing request is added to the certificate list.

- 6 Click the **Active** button for the certificate.
- 7 Click **Save and reboot** and click **OK** to confirm the reboot.

**NOTE:** Depending on the browser you are using, you might receive warnings because the certificate is not signed by a trusted certificate authority.

**To install the certificate on a workstation:**

- 1 Click on the certificate to display the *Certificate details*.
- 2 Click **Download certificate** and save the certificate file as prompted by your browser.

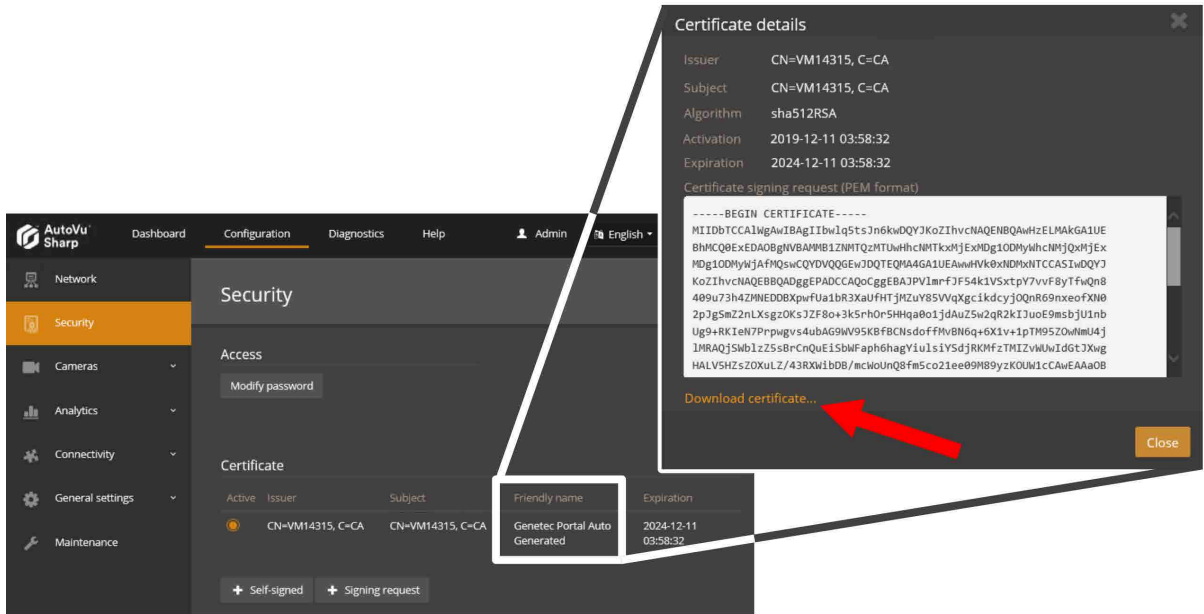

- 3 Double-click the *certificate.cer* file and click **Install Certificate**.
- 4 The *Certificate Import Wizard* prompts you to select a store location. Select **Local Machine** and click **Next**.

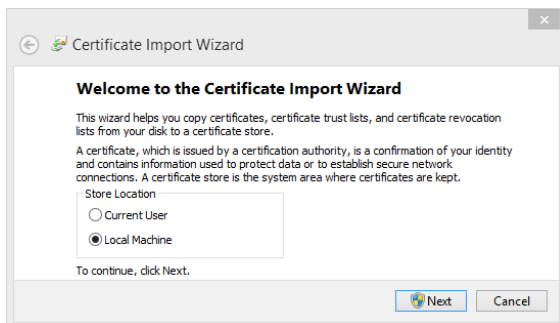

- 5 The wizard prompts you to select the certificate store you want to use. Select **Place all certificates in the following store** and click **Browse**.

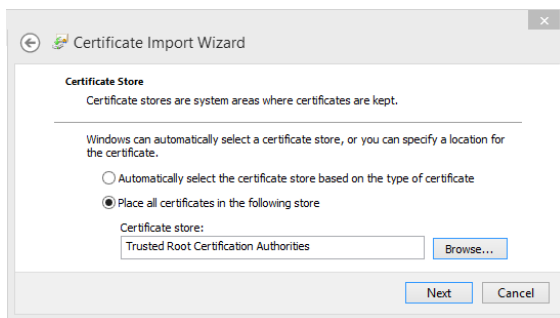

- From the **Select Certificate Store** window, select **Trusted root certification Authorities** and click **OK**.

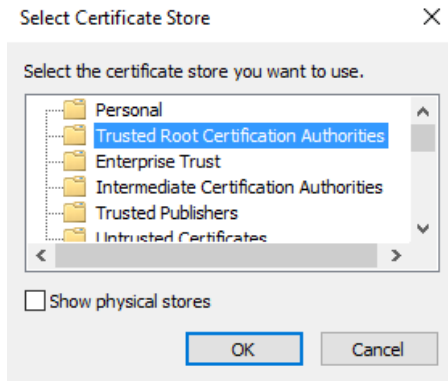

- Click **Next** to continue, and click **Finish** to close the wizard.  
The system displays the message: *The import was successful.*
- Close all web browsers and open the Windows Task Manager to ensure that no browser processes are running in the background.
- Log on to the Sharp Portal. You are automatically logged on in HTTPS mode.  
A lock icon (  ) in the browser's address bar indicates that you are now logged on to the SharpZ3 with a secure connection.

## Installing a signed certificate

If the SharpZ3 unit uses a signed certificate from your own public key infrastructure (PKI) or from a Certificate Authority such as VeriSign, you must install the certificate on all machines that communicate with the SharpZ3 unit.

### Before you begin

Read about [how the Sharp Portal must be encrypted](#).

### What you should know

IPv6 static addresses are not supported.

#### To encrypt the connection to the Sharp Portal using a signed certificate:

- On the machine where you want to register the certificate, log on as an Administrator.
- [Log on to the Sharp Portal](#).
- From the **Configuration** menu, select the *Security* page.
- Click **+ Signing request**.
- Enter the required information for the certificate signing request and click **OK**.

#### NOTE:

- The **Country** field requires a two-letter country code.
- If you are also using the certificate to connect to the Archiver, the **Sharp's common name** (Sharp's IP address if connecting to the Archiver) defined in the certificate must be the Sharp unit's IP address, not the Sharp name.

The message *Operation succeeded* is displayed and the signing request is added to the certificate list with *not signed* displayed for the **Issuer**.

- Click on the certificate to display the *Certificate details*.

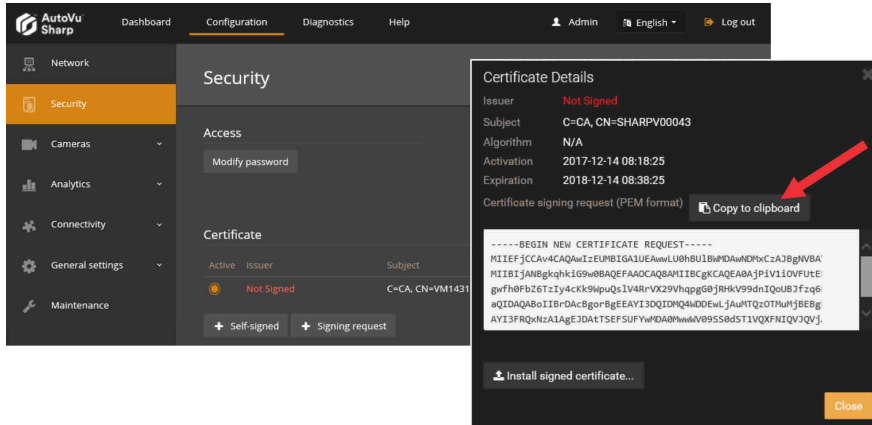
7 Click **Copy to clipboard**.

## 8 Send the certificate signing request to a certificate authority.

**IMPORTANT:** Do not delete the signing request if it has been used to request a certificate.

You will receive an SSL certificate signed by the certificate authority.

9 In the *Certificate Details* window, click **Install signed certificate** then browse to the certificate location and click **Open**.10 Click **Save**.

The system displays the message: *Installed signed certificate... successful*.

## 11 Refresh the browser (F5).

The certificate is displayed in the **Certificate** list.

12 Click the **Active** button for the certificate.13 Click **Save and reboot** and click **OK** to confirm the reboot.

When the system comes back online, notice that the URL displays that you are in HTTPS mode. A lock icon (  ) in the browser's address bar indicates that you are now logged on to the SharpZ3 with a secure connection.

## About SharpZ3 exposure adjustment

We recommend that you keep the default SharpZ3 exposure settings. If you notice that license plates are often under-exposed (too dark) or over-exposed (too bright), you can adjust the exposure settings. However, there are many factors to consider in order to account for changing lighting conditions.

**IMPORTANT:** Modifying the SharpZ3 exposure settings can greatly impact ALPR performance. Vanity plates, or plates that are damaged or dirty can have different reflective properties. Improving the exposure using a stationary test plate can result in reduced ALPR performance on every-day traffic which includes plates with a wide range of reflective properties. You must test the system after modifying these settings.

Consider the following:

- In a correctly-exposed license plate image, the characters and the plate state are dark and well-defined, and the background is white or very bright.



- In the ALPR image, it is normal that the surroundings of the plate are under-exposed while the plate itself is correctly-exposed. Make sure that the plate is correctly exposed and ignore the quality of the surroundings.
- Modifying settings to improve read performance at night can have a negative impact on read performance during the day, and vice versa. Therefore, you must test the settings both at night and during the day (under sun illumination).
- If the SharpZ3 is expected to read both embossed and flat license plates, perform the day instructions with the flat plate and the night instructions with the embossed plate.

## Setting custom SharpZ3 ALPR camera exposure levels

If the default exposure settings do not produce acceptable results, you can adjust the SharpZ3 ALPR camera exposure settings.

### Before you begin

- Read [about SharpZ3 exposure adjustment](#).
- Ensure that the lighting conditions match what is expected during normal camera operation.

#### To adjust the SharpZ3 ALPR camera exposure settings

- 1 Place a stationary license plate as close to the camera as possible while still being within range for the camera to capture plate reads.
- 2 [Log on to the Sharp Portal](#).
- 3 From the **Configuration** menu, click **Cameras > Exposure**.
- 4 From the **Cameras** menu, click the **ALPR camera** you want to calibrate.
- 5 From the **Exposure** menu, click **Range (outdoor)**.

**Gain** and **Exposure time** settings are displayed.

**NOTE:** The ranges for the **Exposure time** and **Gain** settings must be large enough to allow good quality images in all lighting conditions, but you should reduce the range as much as possible. If the range is too large, it increases the risk of over-exposure or under-exposure. It is normal that the SharpZ3 constantly varies the exposure of the ALPR camera in order to get a correct exposure of a plate.

**TIP:** If you want to test using specific exposure settings rather than a range, use the **Fixed (indoor)** configuration from the **Exposure** menu. However, the setting should be set back to **Range (outdoor)** for normal operation so that the camera can adapt its exposure to varying lighting conditions.

- 6 With the plate close to the camera, set the **Gain** value to the minimum default value and adjust the **Exposure time** until you are satisfied with the plate image.
- 7 With the plate further from the camera, check to see that the plate is not too dark. If it is, increase the **Exposure time**.
- 8 (Optional) If you reach the maximum possible **Exposure time** and you are still not satisfied with your plate image, increase the **Gain**.
- 9 When you are satisfied with the appearance of the plate images in the video feed window, click **Save**. The system displays the message *Configuration saved successfully*.

## After you finish

Modifying the exposure settings can greatly impact ALPR performance. Test the system after modifying these settings.

## Troubleshooting outdoor exposure issues for the SharpZ3 ALPR camera

You can resolve exposure adjustment issues that result in under-exposed or over-exposed license plate images in SharpZ3 installations.

### If ALPR images (or some specific plate models) are always too dark at night:

- 1 Perform the exposure calibration at night.
- 2 Increase the maximum **Shutter time** value until you are satisfied with the ALPR images.
- 3 If you reach the maximum **Shutter time** level and the ALPR images are still too dark, increase the maximum **Gain** value.

### If ALPR images are often too dark at night:

In this case, the exposure setting range might be too large, causing exposure to be too low. To reduce the range, start by increasing the minimum values. Because higher minimum values might lead to over-exposure for daytime reads, perform the adjustment during the day.

In this case, the exposure setting range might be too large, causing exposure to be too low. You can reduce the range by increasing the minimum values, but you should do this carefully because increasing the minimum values can cause over-exposure during the day. Therefore, this adjustment should be done during the day.

- 1 Make the adjustment under sun illumination.
- 2 Increase the minimum **Exposure time** value as much as possible without compromising image quality.
- 3 If the minimum **Exposure time** value reaches its maximum value, then you can increase the minimum **Gain** value. Test to make sure image quality is still satisfactory.

### If ALPR images (or some specific plate models) are always too dark even under sunlight:

- 1 Increase the maximum **Exposure time** level as much as possible without over-exposing the plate.
- 2 If the maximum **Exposure time** reaches its maximum value and the plate is still under-exposed, increase the maximum **Gain** value one step at the time until you are satisfied with the images.

### If ALPR images (or some specific plate models) are always too bright under sunlight:

- 1 Make the adjustment under sun illumination.
- 2 Decrease the minimum **Gain** value until you are satisfied with the plate images.

- 3 If you reach the minimum **Gain** level and the ALPR images are still too bright, decrease the minimum **Exposure time** value.

**If ALPR images are often too bright under sunlight:**

In this case, the **Exposure time** range might be too large, causing exposure to be too high. You can reduce the range by decreasing the maximum values, but you should do this carefully because decreasing the maximum values can cause under-exposure at night. Therefore, this adjustment should be done during the night.

- 1 Make the adjustment at night.
- 2 Decrease the maximum **Gain** value as much as possible without compromising image quality.
- 3 If the maximum **Gain** value reaches its minimum value, then you can decrease the maximum **Exposure time** value. Test to make sure image quality is still satisfactory.
- 4 If you reach the minimum **Exposure time** level and you are still not satisfied with the image quality, perform the [complete day and night exposure adjustment again](#).

## Troubleshooting outdoor exposure issues for the SharpZ3 context camera

You can resolve exposure adjustment issues that result in under-exposed or over-exposed context images in a SharpZ3 installation.

**If context images are blurry on fast-moving vehicles:**

- 1 Make the adjustment at night.
- 2 Decrease the maximum **Exposure time** value until the blur caused by vehicle motion is acceptable.

**If context images are noisy during the night:**

- 1 Make the adjustment at night.
- 2 (Optional) Select **Allow illuminator**. This allows the camera to turn on the IR illuminator under dark conditions, but removes color from the image as the light level diminishes.
- 3 Decrease the maximum **Gain** value. This prevents the camera from amplifying the noise, but it can result in darker images.
- 4 (Optional) Increase the maximum **Exposure time**. Note that this can increase the blur caused by vehicle motion.

**If context images are too dark during the night:**

- 1 Make the adjustment at night.
- 2 (Optional) Select **Allow illuminator**. This allows the camera to turn on the IR illuminator under dark conditions, but this progressively removes color from the image as the light level diminishes.
- 3 Increase the maximum **Exposure time** value until you are satisfied with the image quality. However, do not exceed the level that causes unacceptable motion blur on fast-moving vehicles.
- 4 If you reach the maximum **Exposure time** value and the image is still too dark, increase the maximum **Gain** value.

**If context images are too bright during the day:**

- 1 Make the adjustment under sun illumination.
- 2 Decrease the minimum **Gain** value until you are satisfied with the image quality.
- 3 If you reach the minimum **Gain** value and the image is still too bright, decrease the minimum **Exposure time** value.

## Configuring SharpZ3 position and location

Based on the position of the patrol vehicle when a license plate is read, the SharpZ3 system can calculate the location of the target vehicle. To improve geocoding precision, you must define the exact location of the SharpZ3 cameras on the patrol vehicle roof.

### What you should know

- To configure the camera orientation, you must measure the angle of the SharpZ3 cameras. For best results, use a digital level.
- The vehicle image on the *Camera position and orientation* page in the Sharp Portal dynamically updates to show the approximate position of the camera.

#### To configure the position of the SharpZ3 cameras:

- 1 [Log on to the Sharp Portal](#).
- 2 From the **Configuration** menu, click **Cameras > Position and orientation**.
- 3 From the **Cameras** menu, select the first SharpZ3 camera you want to configure.
- 4 Click **Enable** to turn on the feature for the camera.
- 5 Enter **Position** measurements in centimeters to indicate where the front of the camera is in respect to the GNSS antenna.

**IMPORTANT:** Take your measurements from the GNSS antenna to the front of the camera. Do not measure from the center of the vehicle.

As you enter positive or negative values, the camera moves on the vehicle image. This helps you to confirm that you have entered the correct positive or negative values.





- 6 Measure the camera's pan, tilt, and roll using a digital level and enter the **Orientation** values.

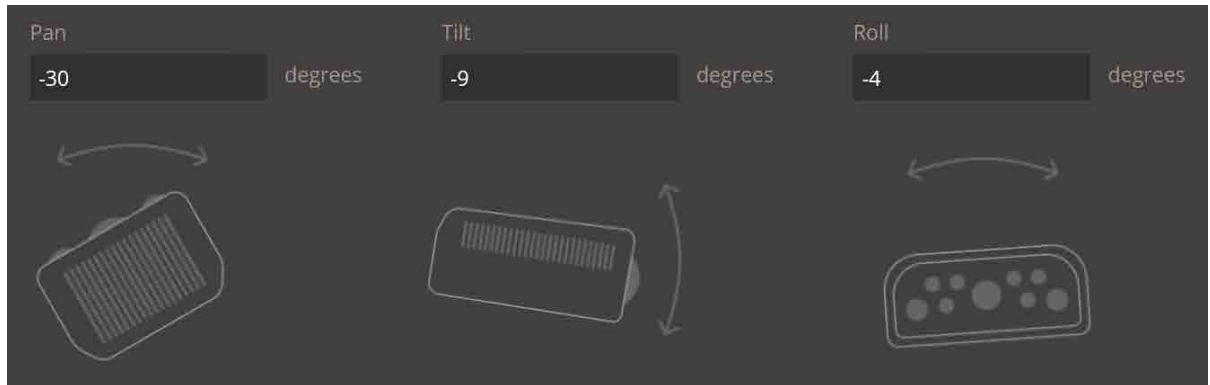

- 7 Click **Save**.

### **After you finish**

Repeat these steps for the remaining SharpZ3 cameras.

# Associating wheel-imaging cameras with SharpZ3 camera units

---

If the SharpZ3 system includes wheel-imaging cameras connected to an AUX PoE expansion module, then you must associate the right and left wheel-imaging cameras with their respective SharpZ3 camera units.

## Before you begin

Connect wheel-imaging cameras to the AUX PoE expansion module.

## What you should know

- On the *Auxiliary cameras* page, you can associate up to two wheel-imaging cameras with SharpZ3 cameras. Typically, left and right wheel-imaging cameras are associated with left and right SharpZ3 cameras, however, you can also associate one wheel-imaging camera with more than one SharpZ3 camera.
- If the wheel-imaging cameras are not connected to the AUX PoE expansion module ports, you can pre-associate the ports with the correct SharpZ3 camera units.

### To associate wheel-imaging cameras with SharpZ3 cameras:

- 1 [Log on to the Sharp Portal.](#)
- 2 From the **Configuration** menu, click **Cameras > Auxiliary cameras.**

- For each SharpZ3 **Camera unit** displayed in the *Wheel-imaging camera association* section, associate a wheel-imaging camera from the **Associated AUX PoE camera** menu.

The **Associated AUX PoE camera** menu displays the SharpZ3 base unit expansion slot (EXP) and port numbers for each of the installed AUX PoE expansion modules. If the light is green, the camera is connected and accessible.

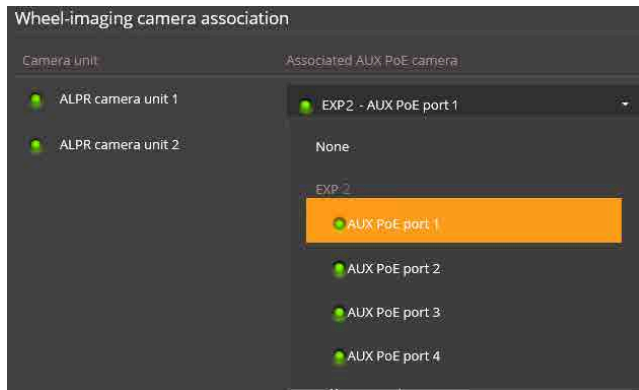

**TIP:** If you are not sure which port a wheel-imaging camera is connected to, check the video feed for the auxiliary cameras in **Dashboard > Camera feeds**.

**NOTE:** The same wheel-imaging camera can be associated with more than one SharpZ3 camera, typically one per car side.

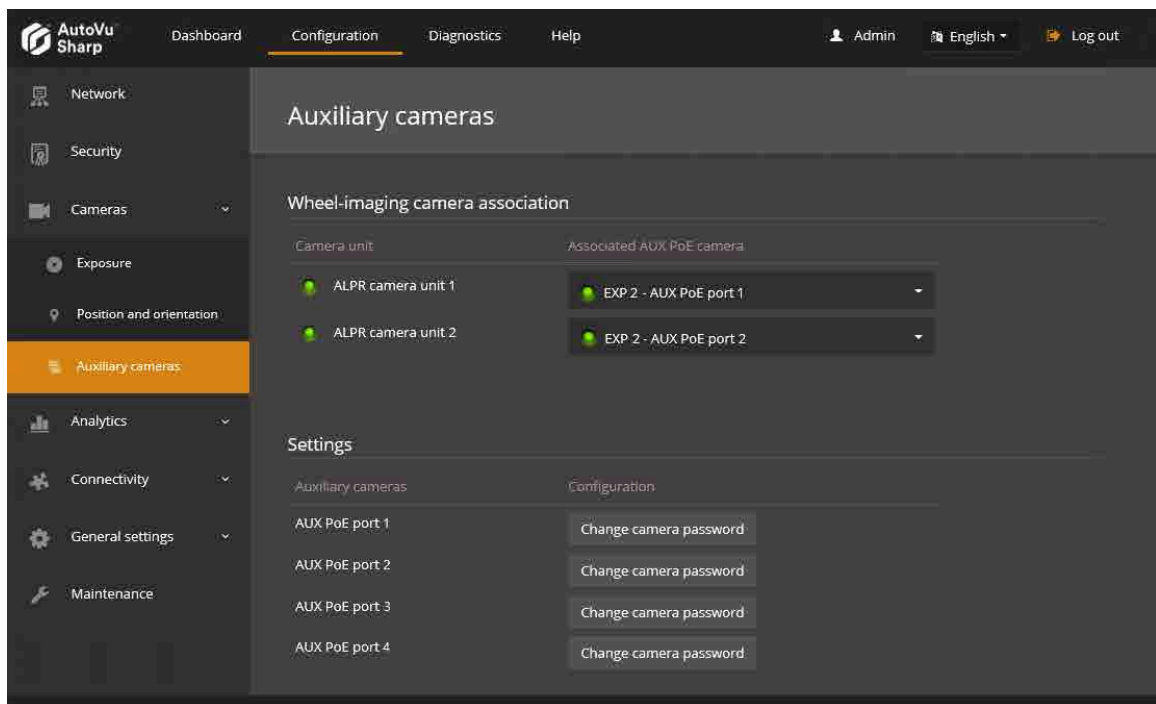

- Click **Save**.

## After you finish

- If required by local regulations, click **Change camera password** and modify the password from the default Username: *admin* and Password: *1234*.

**NOTE:** If you change the AUX PoE expansion module port connection after you change the password, you must reapply the password.

2. Configure wheel imaging settings in Genetec Patroller™. For more information, see the *Genetec Patroller™ Administrator Guide*.

**Related Topics**

[Aux PoE expansion module connections](#) on page 50

## Configuring SharpZ3 analytics

---

To ensure the highest license plate read accuracy, you must let the SharpZ3 system know what type of license plates to expect in the image. If required, you can also configure the system to extract additional information from the image, such as the license plate origin and the vehicle type.

### To configure SharpZ3 analytics:

- 1 [Log on to the Sharp Portal](#).
- 2 From the **Configuration** menu, click **Analytics > ALPR settings**.
- 3 From the **Context** menu, select which license plates will be most commonly read by the SharpZ3.
 

**NOTE:** For more information on the available regional contexts, see [Supported ALPR contexts](#) on page 11.

**TIP:** To help us improve the performance of regional contexts, click **Configuration > Connectivity > Product improvement** and register this camera to participate in the [Product improvement program](#).
- 4 From the **Reading mode** menu, select one of the following reading modes:
  - **Continuous:** Select this to capture plate reads continuously. This is the default setting.
  - **Conditional:** Select this to capture plate reads continuously as long as the selected input signal meets the defined high or low condition.
  - **Multiconditional:** Using this option, you can configure the system to generate reads from a specific camera only while an input's status meets the defined high or low condition. This option is required if using the AutoVu™ car camera switch.
- 5 From the **Read strategy** list, select a read strategy:
  - **Slow moving vehicle:** Applicable for use in typical city, law enforcement, or mobile parking enforcement.
  - **Fast moving vehicle:** Applicable for installations where vehicles travel at moderate to high speeds. For example, use this read strategy for law enforcement installations where vehicles might be traveling at high speeds in opposite directions.
- 6 Under **Analytics**, select the contents of the plate you would like the SharpZ3 to attempt to read. You can select the following:
 

**NOTE:** You can add the state, vehicle make, and confidence score as annotation fields in Security Center to query for this information in Security Desk reports.

  - **State:** Select this option if you want the SharpZ3 unit to attempt read the license plate origin. Depending on the region, this can refer to the issuing state, province, or country.
 

**NOTE:** For more information, see [Supported plate origin recognition](#) on page 14.
  - **Vehicle make:** Select this option if you want the SharpZ3 unit to attempt to read the vehicle's make from the brand or logo (Honda, Toyota, and so on).
 

**NOTE:** This setting is not recommended for MLPI installations.
  - **Confidence score:** The SharpZ3 assigns a confidence score percentage to each license plate read. This value indicates how confident the SharpZ3 is in the accuracy of the read.
 

**NOTE:** License plates that contain similar characters such as *8* and *B* are more difficult to read and generally produce reads with a lower confidence score.
  - **Vehicle type and color:** Select this option if you want to include the vehicle type and vehicle color with plate reads. Based on the context image, the Sharp unit can detect if the vehicle is a bus, passenger vehicle, motorcycle, pickup, truck, work van, or an unknown vehicle type. In addition, the Sharp

unit can detect if the vehicle is black, white, blue, brown, green, gray, orange, red, or yellow. Colors excluding white and black are also assigned *light*, *neutral*, or *dark* according to the color analysis.

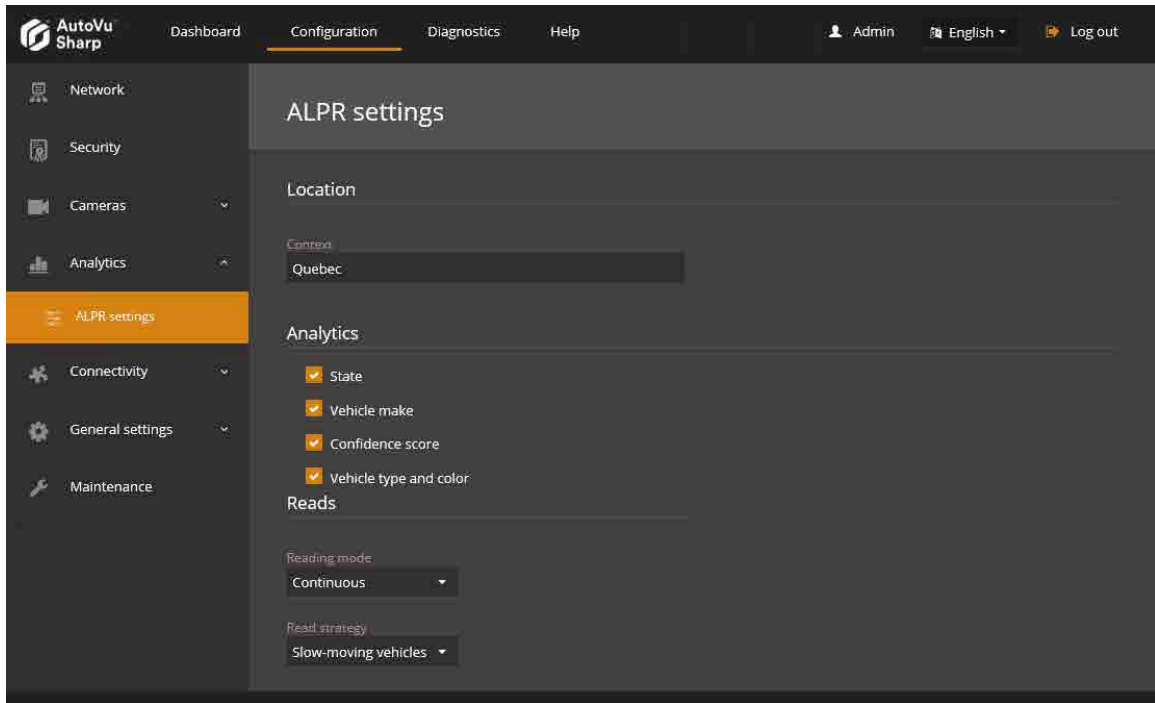

7 Click **Save**.

## Configuring where the SharpZ3 sends its ALPR data

Depending on what type of Sharp camera installation you are configuring, license plate reads can be sent to, Genetec Patroller™, or to an FTP or HTTP server.

### What you should know

- The default extension depends on the hardware you are installing. For example, if you log on to the Sharp Portal for a SharpZ3, the default extension is *Patroller*.
- For FTP and HTTP extensions, plate reads and images are automatically stored if the connection is lost, however, you can disable edge storage using the **Retain data when the connection is lost** setting in the extension configuration. To reduce cellular data usage, you can also configure whether the ALPR and context images are exported.

#### To configure the SharpZ3 extension:

- 1 [Log on to the Sharp Portal](#).
- 2 From the **Configuration** menu, click **Connectivity > Extension**.
- 3 From the **Extension type** menu, select one of the following:
  - **FTP:** Use this option to send ALPR data to an FTP server. You can configure the FTP XML template which can be integrated by third-party applications. For more information, see [Configuring the SharpZ3 FTP extension](#) on page 158.
  - **HTTP/HTTPS:** Use this option to send ALPR data to an HTTP server. You can configure the system to send the data in XML or JSON format. For more information and examples of the exported XML and JSON files, see [Configuring the SharpZ3 HTTP/HTTPS extension](#) on page 161.
  - **Patroller:** Sends ALPR data to Genetec Patroller™. Configure the following:
    - **Discovery port:** Port on which the SharpZ3 listens for discovery requests. This port number must match the discovery port entered on the Genetec Patroller™ Config Tool *Cameras* page.

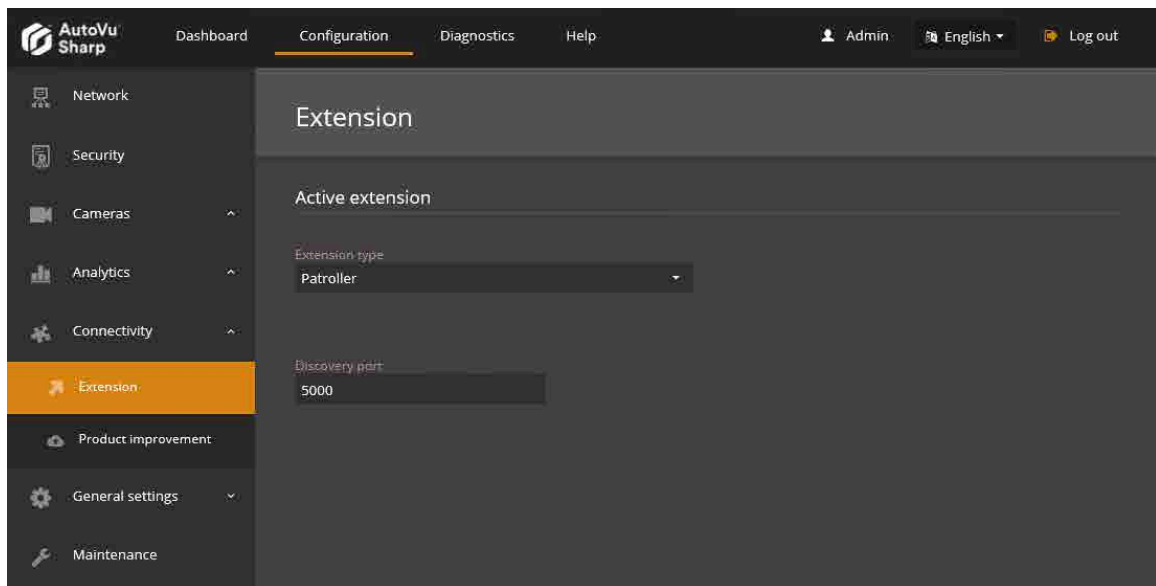

- 4 Click **Save**.

## SharpZ3 communication ports

For SharpZ3 cameras to communicate with Security Center, the correct communication ports must be defined.

**IMPORTANT:** Exposing the AutoVu™ system to the internet is strongly discouraged without hardening your system first. Before exposing your system, implement the advanced security level described in the *Security Center Hardening Guide* to help protect your system from Internet-based threats.

The following table lists the default network ports used by the SharpZ3 system. For a full list of ports used by AutoVu™ applications in Security Center, see the *Security Center Administrator Guide*.

### To connect to the Sharp Portal:

Application	Inbound	Outbound	Port usage
Portal Server (Sharp unit)	TCP 443		Secure communication port (HTTPS)

### To connect to Genetec Patroller™:

Application	Inbound	Outbound	Port usage
Genetec Patroller™ (in-vehicle computer)	TCP 4546		Communication with Time server
	TCP 8001		Communication with Simple Host
		UDP 5000	Sharp camera discovery
		TCP 8731	LPR Manager connection

### Product improvement program (Sharp unit) :

Application	Inbound	Outbound	Port usage
Product improvement program		TCP 443	Product improvement program data (HTTPS)



# About SharpZ3 network settings

By default, the SharpZ3 base unit and modules communicate using their default static IP addresses and no configuration is required.

## Static IP addresses

The following default static IP addresses are assigned to the SharpZ3 base unit, ALPR module, and expansion modules.

Module	Default static IP address
ALPR module ports 1 and 2	192.168.10.1
ALPR module ports 3 and 4	192.168.10.2
EXP 1	192.168.10.30
EXP 2	192.168.10.40
EXP 3	192.168.10.50

If there are no specific IP address range requirements for the installation, no configuration is required. If the system must use IP addresses within a specific range, [you can assign them manually](#).

### IMPORTANT:

- When assigning specific IP addresses, ensure the configuration stays compatible with the rest of the system, otherwise the base unit, expansion modules, or aux cameras might be unreachable. For example, it is important that all components be on the same subnet.
- If you change the static address of the ALPR module, it may invalidate its security certificate and could require replacement; communications might be blocked in the interim.
- You must use a fixed IP address if you want to stream video to the Security Center Archiver role. You can do this using a static IP address or a reserved IP address on the DHCP server.

## DHCP

If the patrol vehicle uses a DHCP server, you can configure the SharpZ3 system for DHCP. Consider the following:

- When a SharpZ3 system is configured to use DHCP, the setting applies to the ALPR module, but does not apply to expansion modules. Expansion modules connected to the base unit always use static IP addresses that are defined on the *Network* page. For the expansion modules to work with the DHCP system, you must configure a compatible **Subnet mask** and **IP address** for each module.
- When a SharpZ3 is configured in DHCP and the DHCP server cannot be reached, the default fall-back IPv4 address is 192.168.10.100. On a four-camera ALPR module, the second group of two cameras has a default fall-back address of 192.168.10.101.

**NOTE:** The default fallback takes at least two minutes to become effective when no DHCP server is detected at bootup.

## Configuring the SharpZ3 system to use a specific IP address range

By default, the SharpZ3 base unit and modules communicate using their default static IP addresses and no configuration is necessary. If required, you can define new static IP addresses within a specific range.

### Before you begin

Learn about [SharpZ3 network settings](#).

### What you should know

The IP address range that is assigned to the SharpZ3 system must account for the SharpZ3 base unit and all connected modules.

In an example using a 192.168.0.X range, the following addresses are required when all SharpZ3 expansion slots are in use:

Module	Default static IP address
ALPR module ports 1 and 2	192.168.0.1
ALPR module ports 3 and 4	192.168.0.2
EXP 1: Navigation expansion module	192.168.0.30
EXP 2: AUX PoE expansion module 1	192.168.0.40
	192.168.0.41 (Port 1)
	192.168.0.42 (Port 2)
	192.168.0.43 (Port 3)
EXP 3: AUX PoE expansion module 2	192.168.0.44 (Port 4)
	192.168.0.50
	192.168.0.51 (Port 1)
	192.168.0.52 (Port 2)
	192.168.0.53 (Port 3)
	192.168.0.54 (Port 4)

#### To configure the SharpZ3 system to use a specific IP address range:

- 1 [Log on to the Sharp Portal](#).
- 2 From the **Configuration** menu, select the *Network* page.
- 3 Select **Use static IP address**.  
The network settings are displayed for the ALPR module for each installed expansion module.
- 4 In the **IPv4 network settings** section, configure the ALPR module network settings, .  
You can modify the following:
  - **IP address:** Enter the new IP address you want to assign to the ALPR module. The default is 192.168.10.1 (port 1 and 2) and 192.168.10.2 (port 3 and 4).
  - **Subnet mask:** Enter the new **Subnet mask** for the ALPR module, if applicable. The default is 255.255.255.0.

**IMPORTANT:** When assigning specific IP addresses, ensure the configuration stays compatible with the rest of the system, otherwise the base unit, expansion modules, or aux cameras might be unreachable. For example, it is important that all components be on the same subnet.

- **Gateway:** Enter the new **Gateway** for the ALPR module, if applicable. The default is 10.0.0.0.
- **DNS:** Enter the new **DNS** for the ALPR module, if applicable. The default is 10.0.0.0.

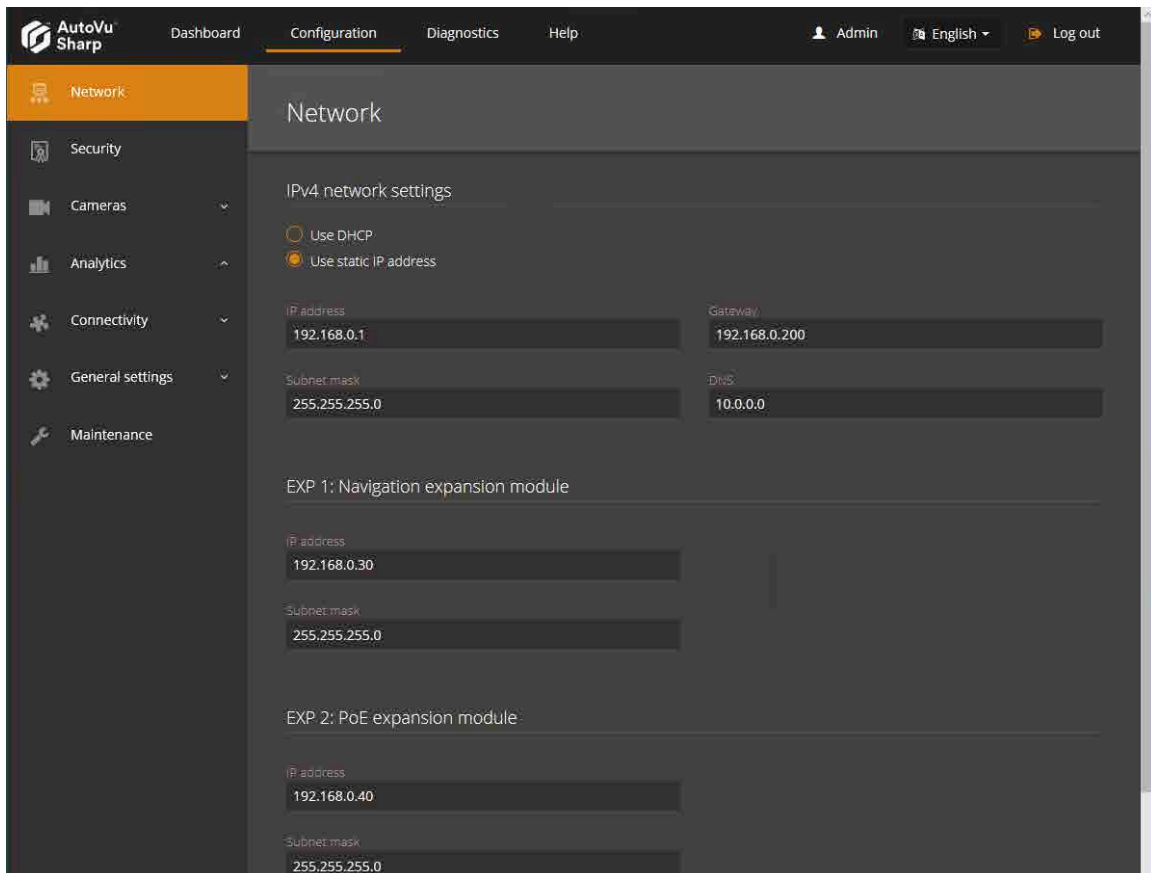

- 5 If the system includes a navigation expansion module, enter its new **IP address** and update the **Subnet mask** if required.
- 6 If the system includes AUX PoE expansion modules, enter their new **IP address** and update the **Subnet mask** if required.

The AUX PoE expansion modules automatically assigns compatible IP addresses to each PoE port on the same subnet. For example if you configure an AUX PoE expansion module to use the static IP address 192.168.0.40, then the first PoE port will be 192.168.0.41, second will be 192.168.0.42, and so on.

- 7 Click **Save**.

- 8 If the ALPR module includes four camera ports, log on to Sharp Portal 2 and enter the new static IP address for the second pair of camera ports.  
A two-camera ALPR module is configured through one Sharp Portal; a four-camera ALPR module is configured through two Sharp Portals.

- **Sharp Portal 1 (camera ports 1 and 2):** <http://192.168.10.1/>
- **Sharp Portal 2 (camera ports 3 and 4):** <http://192.168.10.2/>

## Sharp Portal 1

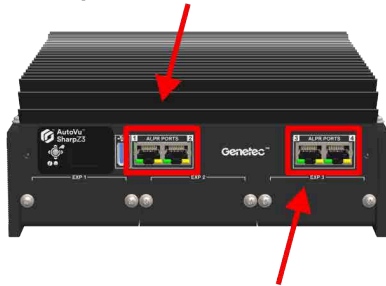

## Sharp Portal 2

- 9 Click **Save**.

# Configuring the SharpZ3 FTP extension

---

You can configure the SharpZ3 to send ALPR data to an FTP server instead of to Genetec Patroller™. ALPR data that is sent to an FTP server can then be processed by third-party applications.

## What you should know

- The connection to the FTP server is made using passive mode. This means that the ports configured on the FTP server for that purpose must all be opened in the firewall and routers located between the Sharp units and the FTP server.
- You can only configure one extension for the SharpZ3 unit.

### To configure the SharpZ3 for FTP:

- 1 [Log on to the Sharp Portal](#).
- 2 From the **Configuration** menu, click **Connectivity > Extension**.
- 3 From the **Active extension** section, select **FTP** from the **Extension type** menu.
- 4 Configure the following:
  - **Server:** Enter the server name and location of the FTP server.  
**NOTE:** The appropriate rights on that location must be granted to the chosen user on the FTP server. The target directory must also be present and be writable by that user.
  - **Username:** Enter the username for the server.
  - **Password:** Enter the password for the username.
  - **Content Template:** ALPR data is sent in XML format, using the template shown. You can change certain elements if you choose.
  - **Export context images:** Export the context image (in JPEG format).
  - **Export ALPR images:** Export the plate image (in JPEG format).
  - **Retain data when the connection is lost:** Select this option for plate reads to be saved locally in the SharpZ3 database if the connection with the server is lost. The system attempts to reconnect with the server every 30 seconds. Stored reads are pushed to the server when the connection is reestablished.  
**IMPORTANT:** If there are any plate reads in the SharpZ3 database, clearing this check box and saving the configuration deletes the plate reads.
- 5 Click **Test connection** to verify that the server can be reached and that the credentials are valid.

- Click **Send sample** to send a test plate to verify that the system can connect to the server using these settings.

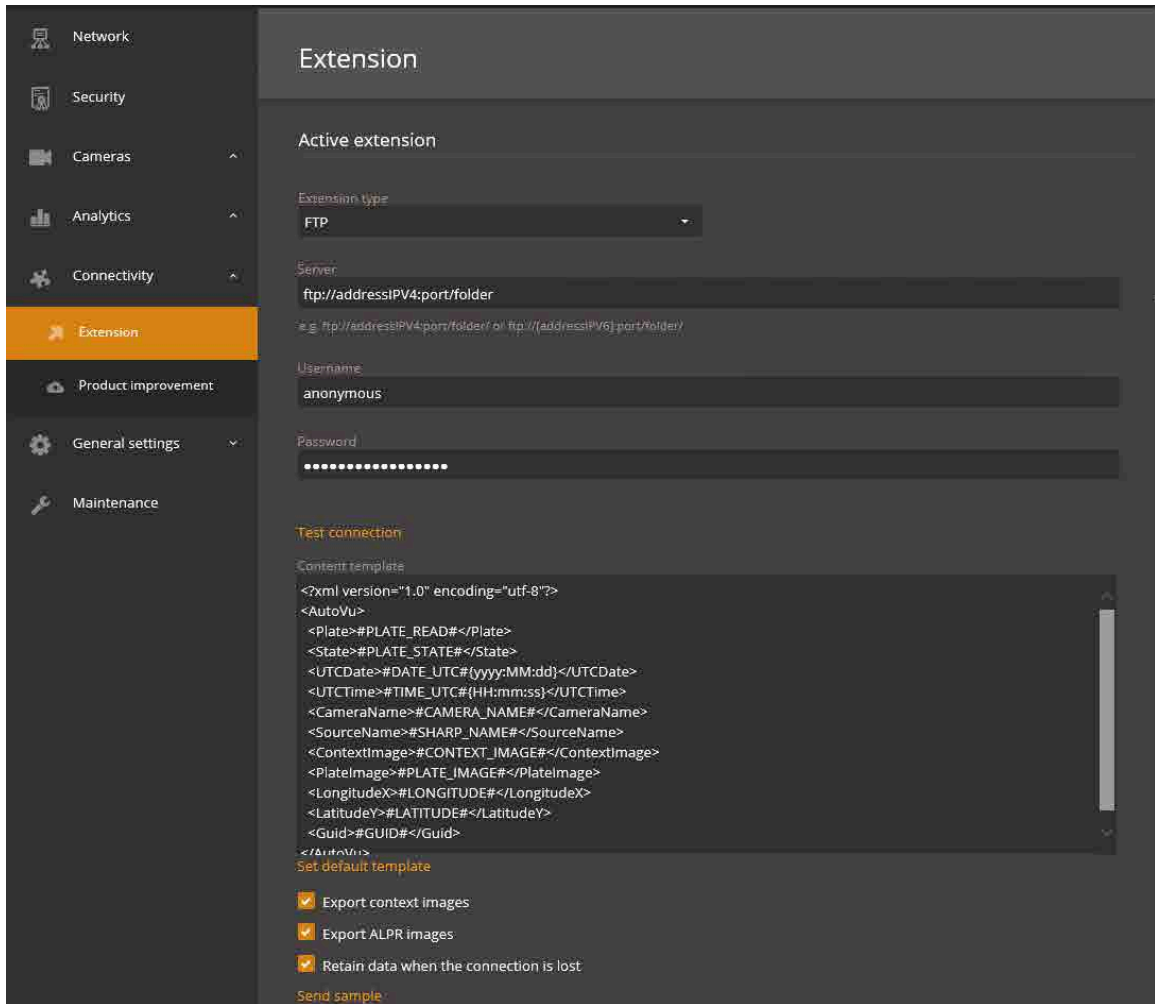

- Click **Save**.

## Modifications you can make to the SharpZ3 FTP XML template

The XML code defines the structure of the XML files generated by the SharpZ3. You can re-sort or remove any of the fields. The XML file name consists of the SharpZ3 name and a unique identification number (for example, SHARP12345\_6ee17b00-82c1-466b-9fd6-003417bc82c4\_lpr.xml).

### Template:

```
<?xml version="1.0" encoding="utf-8"?>
<AutoVu>
  <Plate>#PLATE_READ#</Plate>
  <State>#PLATE_STATE#</State>
  <UTCDate>#DATE.UTC#{yyyy:MM:dd}</UTCDate>
  <UTCTime>#TIME.UTC#{HH:mm:ss}</UTCTime>
  <CameraName>#CAMERA_NAME#</CameraName>
  <SourceName>#SHARP_NAME#</SourceName>
  <ContextImage>#CONTEXT_IMAGE#</ContextImage>
  <PlateImage>#PLATE_IMAGE#</PlateImage>
  <LongitudeX>#LONGITUDE#</LongitudeX>
  <LatitudeY>#LATITUDE#</LatitudeY>
  <Guid>#GUID#</Guid>
</AutoVu>
```

&lt;/AutoVu&gt;

**Note the following:**

- Hotlist matching is not supported.
- UTCDate and UTCTime display the Windows date and time properties.
- CameraName displays the name of the camera, for example, Context Camera.
- SourceName is the SharpZ3 name (for example, Sharp12345).
- ContextImage and PlateImage images are encoded into JPEG and then converted to Base64 (text) for transport and storage in XML / JSON. To use them, you must transform them back into JPEG binary (Base64 -> array of bytes).
- Guid is the unique identification of the event read.
- You can add the following custom fields to the template:
  - **Confidence score:** The SharpZ3 assigns a confidence score percentage to each license plate read. This value indicates how confident the SharpZ3 is in the accuracy of the read. You can add the confidence score associated with the plate read to the XML using the following field:  

```
<ConfidenceScore>#CUSTOM_FIELDS#{Confidence Score}</ConfidenceScore>
```

**NOTE:** License plates that contain similar characters such as *8* and *B* are more difficult to read and generally produce reads with a lower confidence score.
  - **Relative Motion:** When the SharpZ3 reads a plate, it detects and displays if the vehicle is approaching or moving away. To use this field, add the following line to the XML:  

```
<RelativeMotion>#CUSTOM_FIELDS#{Relative Motion}</RelativeMotion>.
```
  - **State Name:** The SharpZ3 attempts to read the plate's origin in addition to the plate number (some plates include the issuing state or province). This may not be possible for all types of license plates. To use this field, add 

```
<State>#CUSTOM_FIELDS#{State Name}</State>
```

 to the XML, and then select *State* on the *Analytics* page of the **Configuration** menu in the Sharp Portal.  

**NOTE:** The ALPR context you are using must support the state name feature.
  - **Vehicle Type:** Certain license plates include character symbols that identify specific vehicle types (for example, taxi, transport, and so on). If the SharpZ3 can read these symbols, it displays the vehicle type along with the other read and hit information. To use this field, add the following line to the XML:  

```
<VehicleType>#CUSTOM_FIELDS#{Vehicle Type}</VehicleType>.
```

# Configuring the SharpZ3 HTTP/HTTPS extension

---

You can configure the SharpZ3 to send ALPR data to an HTTP server instead of to Genetec Patroller™. ALPR data that is sent to an HTTP/HTTPS server can then be integrated by third-party applications.

## What you should know

You can only configure one extension for the SharpZ3 camera.

### To configure the SharpZ3 for HTTP/HTTPS:

- 1 [Log on to the Sharp Portal](#).
- 2 From the **Configuration** menu, click **Connectivity > Extension**.
- 3 From the **Active extension** section, select **HTTP/HTTPS** from the **Extension type** menu.
- 4 Configure the following:
  - **Server:** Enter the server name and location of the third party receiving HTTP server.
  - **Format:** Select the format you want to send the ALPR data in. You can select either **JSON** or **XML** format.
  - **Username:** Enter the username for the server.
  - **Password:** Enter the password for the username.
  - **Export context images:** Export the context image (in JPEG format).
  - **Export ALPR images:** Export the plate image (in JPEG format).
  - **Retain data when the connection is lost:** Select this option for plate reads to be saved locally in the SharpZ3 database if the connection with the server is lost. The system attempts to reconnect with the server every 30 seconds. Stored reads are pushed to the server when the connection is reestablished.

**IMPORTANT:** If there are any plate reads in the SharpZ3 database, clearing this check box and saving the configuration deletes the plate reads.
  - **Anonymize ALPR data:** The camera *hashes* the license plate using the SHA-1 algorithm. When you add an alphanumeric *salt (cryptography)* to the license plate number, it increases the security of the hashed output. Adding the same salt on all of the cameras in a network means that the same license plate produces an identical hash on all cameras. This allows the external system to recognize the identical hashes as a the same vehicle while still maintaining privacy.

**IMPORTANT:** If the salt is changed after it is set, it must also be changed on all other cameras. Changing the salt breaks the link between old reads and new reads.
  - **Ignore certificate errors:** Select this option when sending ALPR data to an HTTPS server that does not have a trusted certificate. The SharpZ3 does not send the ALPR data to an HTTPS server that does not have a trusted certificate unless you select this option.



- Click **Send sample** to send a test plate to verify that the system can connect to the server using these settings.

The screenshot shows the 'Extension' configuration page in the AutoVu SharpZ3 web interface. The page is titled 'Extension' and is part of the 'Configuration' section. The left sidebar contains navigation options: Network, Security, Cameras, Analytics, Connectivity, Extension (highlighted), Product improvement, General settings, and Maintenance. The main content area is titled 'Active extension' and contains the following fields and options:

- Extension type:** HTTP / HTTPS
- Server:** https://addressIPv4:port/path/ (with a note: e.g. http://addressIPv4:port/path/ or http://addressIPv6:port/path/)
- Username:** anonymous
- Password:** [masked with dots]
- Anonymize ALPR data
- Ignore certificate errors
- Format:** JSON
- Export context images
- Export ALPR images
- Retain data when the connection is lost
- [Send sample](#)

- Click **Save**.

## Examples of JSON and XML ALPR events for the SharpZ3 HTTP extension

When you send ALPR data to an HTTP server, you can configure the SharpZ3 system to send the data in XML or JSON format.

### JSON format sample:

The following is an example of a license plate read event in JSON format.

**NOTE:** The binary image data has been removed from the example.

```
{ "ContextCameraName" : "Context Camera",
  "ContextImage" : "",
  "Id" : "32cf870a-46aa-4cfd-914b-00062d98e93a",
  "Latitude" : 0.0,
  "Longitude" : 0.0,
  "LprCameraName" : "LPR camera",
  "PlateAnalytics" : [ { "Key" : "State Name",
    "Score" : -1.0,
    "Value" : "-"
  },
  { "Key" : "Vehicle Type",
    "Score" : 1.0,
    "Value" : "-"
  },
  { "Key" : "Relative Motion",
    "Score" : -1.0,
```

```

    "Value" : "- "
  },
  { "Key" : "Context",
    "Score" : 1.0,
    "Value" : "US"
  },
  { "Key" : "Characters Height",
    "Score" : 1.0,
    "Value" : "70"
  }
],
"PlateImage" : "",
"PlateRead" : "AA7D2",
"SourceUrl" : "SharpZ312345",
"Timestamp" : "2020-03-12T08:42:45.797"
}

```

#### XML format sample:

The following is an example of a license plate read event in XML format.

**NOTE:** The binary image data has been removed from the example.

```

<Plate>
  <ContextCameraName>Context Camera</ContextCameraName>
  <ContextImage/>
  <Id>32cf870a-46aa-4cfd-914b-00062d98e93a</Id>
  <Latitude>0.0</Latitude>
  <Longitude>0.0</Longitude>
  <LprCameraName>LPR camera</LprCameraName>
  <PlateAnalytics>
    <PlateAnalytics>
      <Key>State Name</Key>
      <Score>-1.0</Score>
      <Value>-</Value>
    </PlateAnalytics>
    <PlateAnalytics>
      <Key>Confidence Score</Key>
      <Score>1</Score>
      <Value>100</Value>
    </PlateAnalytics>
  </PlateAnalytics>
  <PlateImage/>
  <PlateRead>AA7D2</PlateRead>
  <SourceUrl>SharpZ312345</SourceUrl>
  <Timestamp>2020-03-12T21:35:04.8627622+00:00</Timestamp>
</Plate>

```

#### Plate read event parameters

The following parameters are included in JSON and XML files that are exported to the HTTP server:

Parameter	Value type	Description
<b>ContextCameraName</b>	String	Name of the color context camera that generated the read event.
<b>ContextImage</b>	Binary	Color context image of the scene. Base64 encoded JPEG image.
<b>Id</b>	Guid	Unique identifier for the read event.
<b>Latitude</b>	Double	Decimal latitude of the SharpZ3 camera.
<b>Longitude</b>	Double	Decimal longitude of the SharpZ3 camera.

Parameter	Value type	Description
<b>LprCameraName</b>	String	Name of the license plate recognition camera that generated the read event.
<b>PlateAnalytics</b>	Array of analytics	Each analytic object is composed of a data triplet. This array is of variable size. The amount of analytic objects received depends on the SharpZ3 camera's configuration.
<b>Key</b> (analytic triplet)	String	Name of the analytic.
<b>Score</b> (analytic triplet)	Float (-1.0 or 1.0)	Indicates if the analytic value is reliable (1.0) or not (-1.0).
<b>Value</b> (analytic triplet)	String	Value of the analytic.
<b>PlateImage</b>	Binary	Black and white cropped license plate image. Base64 encoded JPEG image.
<b>PlateRead</b>	String	Detected license plate number.
<b>SourceUrl</b>	String	Unique name of the SharpZ3 camera.
<b>Timestamp</b>	DateTime	Date and time of the read event (UTC) in the following format: yyyy-MM-ddTHH:mm:ss:fff.

# Configuring Syslog for SharpZ3 log files

For installations that include multiple SharpZ3 units, the *Syslog* feature allows you to configure a central repository for all SharpZ3 log entries.

## Before you begin

You must have a Syslog server that is accessible by the SharpZ3 unit.

## What you should know

- The SharpZ3 syslog feature is compliant with the RFC 5424 protocol.
- Whether you use the syslog feature or not, SharpZ3 logs are available on Sharp Portal under **Diagnostics > Logs**.
- When you activate the Syslog server, logs are sent to that server, but are still recorded locally as usual.

### To configure a syslog repository for SharpZ3 log files:

- 1 [Log on to the Sharp Portal](#).
- 2 From the **Configuration** menu, click **General settings > Recovery**.
- 3 Select the **Use Syslog server** checkbox.
- 4 Configure the following:
  - **Use Syslog server:** Select this option to configure a central repository for all SharpZ3 log entries.
    - **Server:** Enter the IP address or name of the server.  
**NOTE:** Syslog server configurations do not support IPv6 addresses.
    - **Port:** Enter the port number of the syslog server.
    - **Network protocol:** Select UDP or TCP.
- 5 Click **Test connection** to verify that the server can be reached.

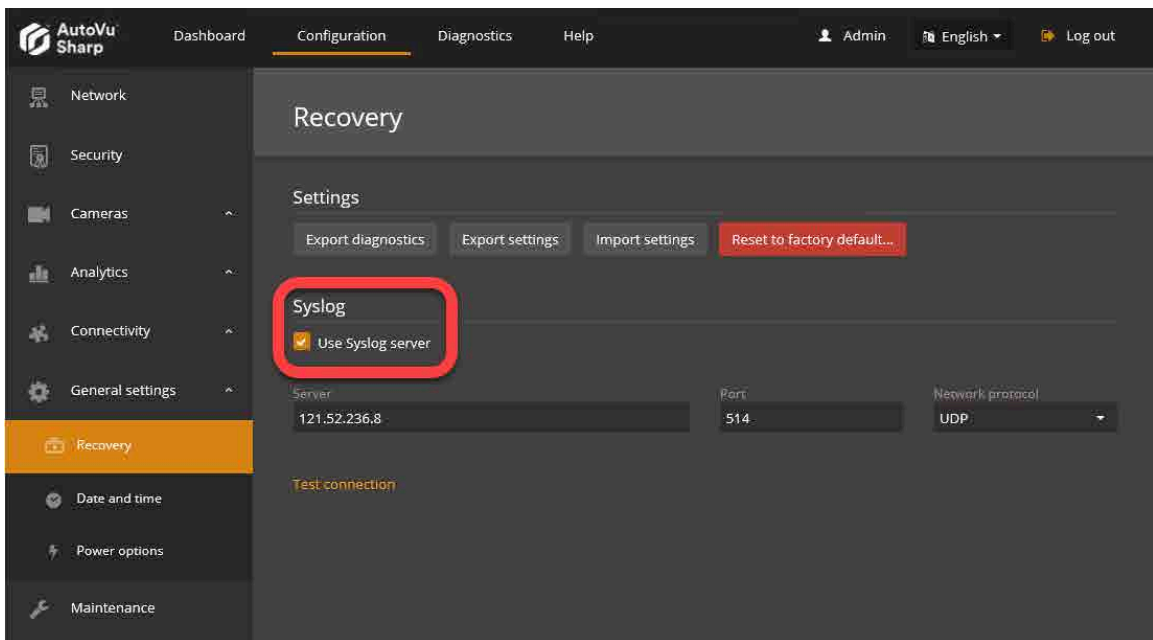

- 6 Click **Save**.

## Importing and exporting settings

You can export SharpZ3 settings for use as diagnostic information if required by the AutoVu™ Support team. You can also use the exported settings file to restore the configuration of the SharpZ3 unit or to copy the configuration to another unit.

### What you should know

- You can only import settings from the same Sharp model, for example, a SharpV can only import settings from another SharpV.
- You cannot export a configuration from a newer SharpOS version to an older SharpOS version.
- **WARNING:** When you import settings to a SharpZ3, the camera's current configuration is lost with some exceptions, including:
  - Sharp Portal password
  - Network static configuration
  - Certificates
  - Product improvement program registration
- Battery monitoring settings are unaffected by the import operation.

#### To export SharpZ3 settings:

- 1 [Log on to the Sharp Portal](#) of the SharpZ3 that you want to export settings from.
- 2 From the **Configuration** menu, click **General settings > Recovery**.
- 3 From the **Settings** section, select one of the following options:
  - **Export diagnostics:** Export a file that includes SharpZ3 diagnostics and SharpZ3 settings.
  - **Export settings:** Exports configuration and diagnostic settings as a .zip file. You can use the .zip file for technical support, or you can import the settings to another Sharp unit for quick configuration

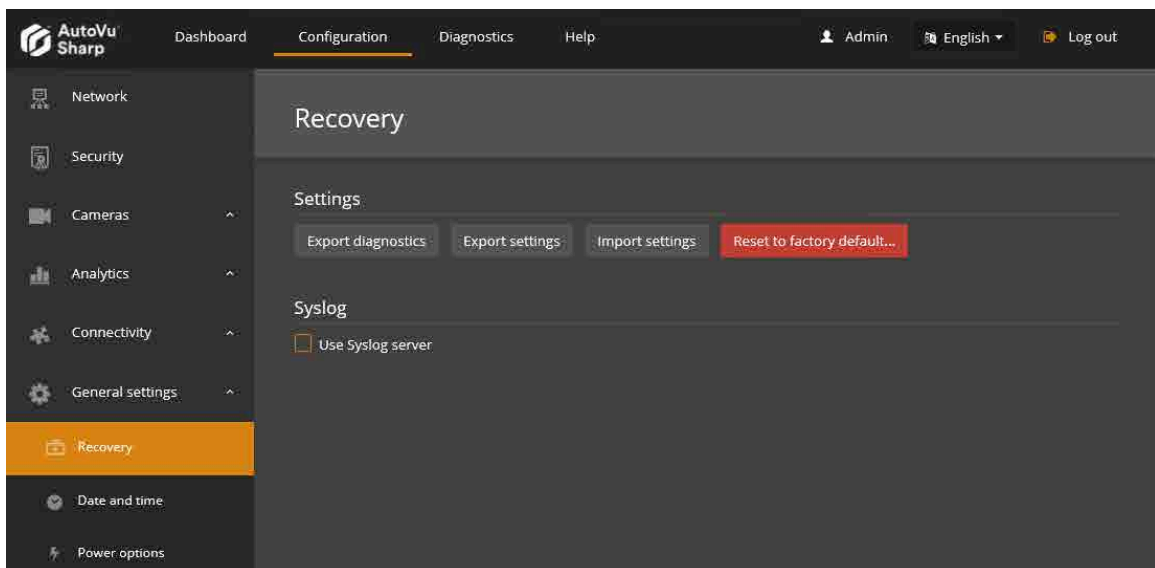

The system prepares the files and displays the message "Download succeeded".

- 4 Save the diagnostics .zip file to a location that is accessible to the browser that is used to view the portal and to the Windows user that will be importing the file. The file is named with the date and time the file was created, for example, `Diagnostics-2020-02-25_12_49_36`.

#### To import SharpZ3 settings:

- 1 [Log on to the Sharp Portal](#) of the SharpZ3 that you want to import settings to.

- 2 From the **Configuration** menu, click **General settings > Recovery**.
- 3 From the **Settings** section, click **Import settings**.
- 4 Enter the path and filename, or browse to the ZIP file with the SharpZ3 settings you want to import and click **Yes, import**.
- 5 Follow the on-screen instructions and import the settings to the camera.

# Completing the deployment

This section includes the following topics:

- ["Completing the deployment"](#) on page 169

# Completing the deployment

---

Before you replace the body liners and other paneling in the vehicle, ensure that the installation does not affect the vehicle's operation or mandated safety functions or circuits.

## What you should know

For software installation and configuration instructions, refer to the *Sharp Administrator Guide* and *Genetec Patroller™ Administrator Guide*.

### To complete the installation:

- 1 Test the system to ensure that the hardware is functional and the wiring is correct and solid.
- 2 Test network communication.
- 3 Test the following vehicle functions:
  - GPS signal
  - Odometry
  - Reverse signal
  - Ignition

## After you finish

When the AutoVu™ installation is finished, include the following information in the field report that is submitted to Genetec Inc.:

- Power connection locations
- Signal connection locations, for example, ignition, odometer, and GPS.
- Diagram the how the wires are routed in the vehicle
- IP addresses of all installed equipment
- Serial number and part numbers of all installed equipment
- Point of contact information for the customer:
  - Name
  - Title
  - Phone number and/or email
- A read report to evaluate the performance.



# Troubleshooting the installation

This section includes the following topics:

- ["LED status on the SharpZ3 camera unit"](#) on page 171
- ["Resetting a lost password for the Sharp Portal"](#) on page 174

## LED status on the SharpZ3 camera unit

The status LEDs on the SharpZ3 camera unit, base unit, ALPR module, and expansion modules respond according to the status of the system.

### SharpZ3 camera LED status



LED	State	Description
Off	Off	The unit is powered-off.
Off	Covert mode	SharpZ3 cameras are configured in covert mode. Following camera startup, their LEDs are deactivated.
Slow red blinking (0.5 seconds off – 0.5 seconds on)	Catastrophic failure	The unit is shut down due to a critical error, for example, an over-temperature alarm. In this state, you cannot connect to the cameras.
Three red blinks per second	Major failure	Internal services are down. You might be able to connect to the cameras and you might be able to see the logs.
One short red blink per second	Performance issues or minor failure	The system is running with important performance issues, for example, failure of the illuminator.
Five green blinks per second	System update	Internal services are down during the system update, but is expected to come back online after the update is complete.
Slow red and green alternating (0.5 seconds each)	Locate camera	After clicking <b>Blink LED</b> in the Sharp Portal, the LED blinks for 10 seconds.
Slow green blinking	Normal mode	The system is running normally.
One green blink per second	System startup	The system is booting up.

## SharpZ3 base unit LED status

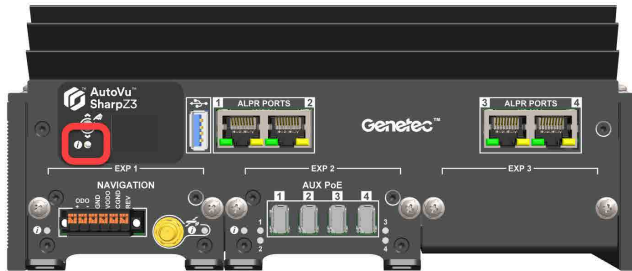

LED	OLED display	State	Description
Off		Off	The unit is powered-off.
Off	CoverMode	Covert mode	SharpZ3 cameras are configured in covert mode. Following camera startup, their LEDs are deactivated.
Slow red blinking (0.5 seconds off – 0.5 seconds on)	C-fail	Catastrophic failure	The unit is shut down due to a critical error, for example, an over-temperature alarm. In this state, you cannot connect to the cameras.
Three red blinks per second	M-Fail	Major failure	Internal services are down. You might be able to connect to the cameras and you might be able to see the logs.
One short red blink per second	Perf Fail	Performance issues or minor failure	The system is running with important performance issues, for example, failure of the illuminator.
Five green blinks per second	Updating	System update	Internal services are down during the system update, but is expected to come back online after the update is complete.
Solid green	Normal	Normal mode	The system is running normally.
One green blink per second	Startup	Camera startup	The system is booting up.

## Navigation expansion module LED status

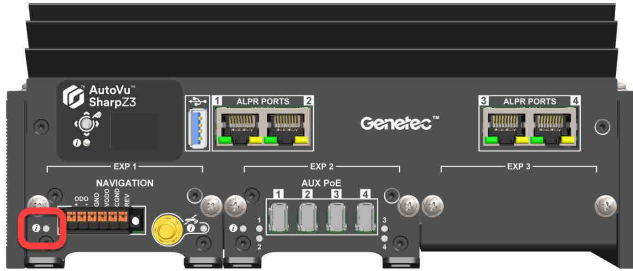

LED	State	Description
Off	Off	The unit is powered-off.
Slow green blinking	Normal mode	The module is running normally.
Slow red blinking	Error	The module is not receiving messages from GNSS chip.

## AUX PoE expansion module LED status

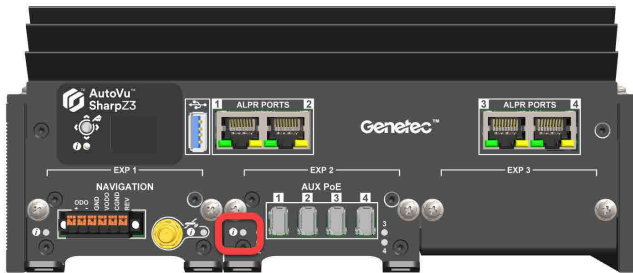

LED	State	Description
Off	Off	The unit is powered-off.
Slow green blinking	Normal mode	The module is running normally.

# Resetting a lost password for the Sharp Portal

If you forget your password to the Sharp Portal for a SharpZ3 system, you can reset the password using the **I forgot my password** button on the Sharp Portal login screen.

## What you should know

- To reset a lost password, you need the yellow *Important information* sticker that was shipped with the SharpZ3 unit. If you do not have the sticker, you must contact the AutoVu™ Support team.



- If you don't see the **I forgot my password** link on the Sharp Portal login screen, it means the Sharp Portal has never been accessed and still uses the default **Username: admin** and **Password: Genetec**. You are prompted to change the default password when you access the Sharp Portal for the first time.

### To reset a lost password for the Sharp Portal:

- From the Sharp Portal login screen, click **I forgot my password**.
- Enter the 32-character **Unit access code**.

You can find the code on the yellow sticker that was provided with the SharpZ3 unit.



- Click **Next**.

- 4 Press and hold the joystick on the SharpZ3 base unit for two seconds.  
This step ensures that the password cannot be reset remotely.

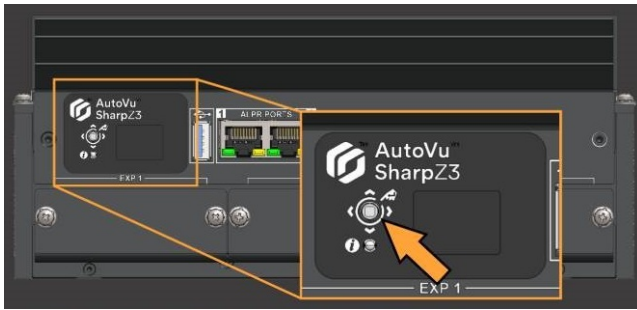

**NOTE:** If you do not press the joystick within two hours, the password recovery operation is canceled.

- 5 When prompted, enter and confirm the new Sharp Portal password.
- 6 Click **Apply**.  
The message *The portal password has been changed* is displayed.  
You are redirected to the logon page.
- 7 Log on to the Sharp Portal using your new password.
- 8 Store your password safely for future use.
- 9 Click **Connect**.

# Updating the system

This section includes the following topics:

- ["Updating a Sharp unit from the SharpOS 13 Sharp Portal"](#) on page 177

# Updating a Sharp unit from the SharpOS 13 Sharp Portal

To benefit from the most recent security improvements, it is recommended to upgrade the unit's SharpOS and platform software from the Sharp Portal.

## Before you begin

If you are updating a SharpZ3 unit, ensure that all of the SharpZ3 cameras are connected to the ALPR module on the base unit.

## What you should know

- You can update the Sharp unit's platform package or SharpOS package.
  - Platform package:** Updates Windows 10 with the latest security patches.
  - SharpOS package:** Updates the SharpOS installed on the Sharp.
- IMPORTANT:** When the SharpOS is updated, any plate reads that are stored locally on the Sharp unit are deleted.
- IMPORTANT:** If you need to update both the SharpOS software and the platform software, update the SharpOS first.
- On a SharpZ3 unit that includes a four-camera ALPR module, each set of two cameras is configured in a separate Sharp Portal which is available from a link on the *Maintenance* page. It is recommended that you update both portals with the same platform and SharpOS packages.

### To update the unit's SharpOS or platform package:

- 1 [Log on to the Sharp Portal.](#)
- 2 To verify that the firmware needs to be updated, click **Dashboard > Overview**. If **Firmware** shows the message *Out of date*, continue with the update steps.

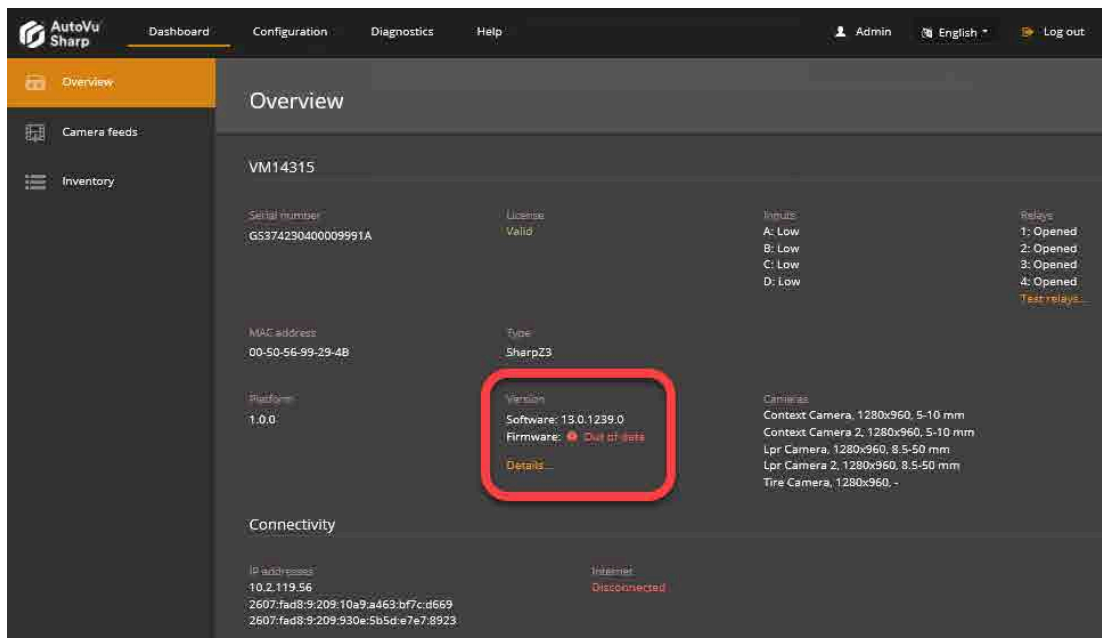

- 3 Download the update package from [GTAP](#). Save the *.gpac* file on the local machine you are using to log on to the Sharp Portal.
- 4 From the **Configuration** menu, select **Maintenance**.
- 5 In the *Packages* section, click the **Update** button for the platform or SharpOS.



- 6 In the *Update package* dialog box, choose when to run the update.
  - Click **Now** to run the update immediately.
  - Click **Specific date** to schedule the update for off-peak hours.
- 7 Click **Add a package**, find the update *.gpac* file, and then click **Open**.
- 8 Acknowledge the warnings and click **Update** or click **Schedule** if you set a specific date for the update.

**IMPORTANT:**

- Whether you configure the update for **Now** or for a **Specific date**, the package is transferred to the Sharp unit immediately. Do not close or navigate away from the browser page until the transfer is complete.

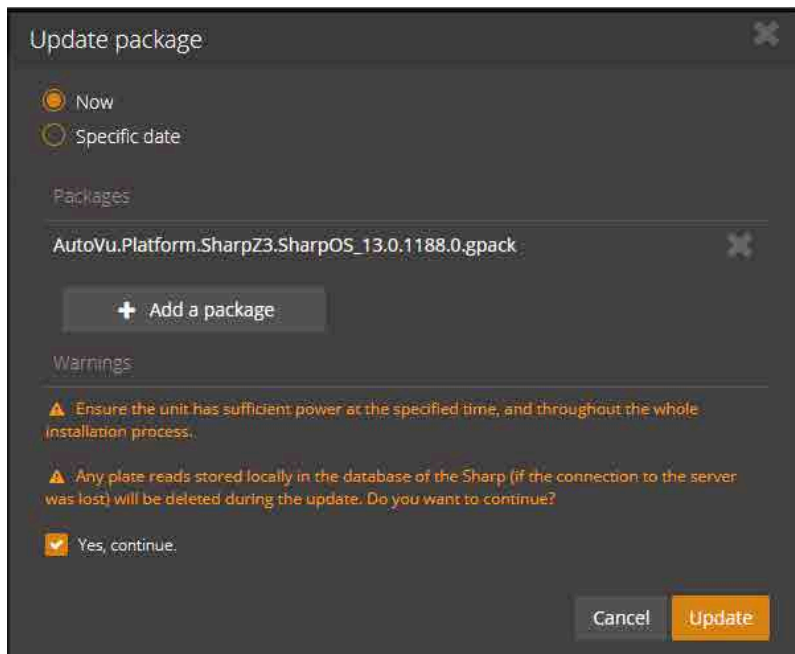

The files are transferred to the Sharp unit and the update process begins.

**NOTE:** At certain points in the update process, the progress bar might not move for several minutes. It can take up to 30 minutes to complete the update.

If the update is successful, the new platform version is displayed and the **History** displays that the update *Succeeded*.

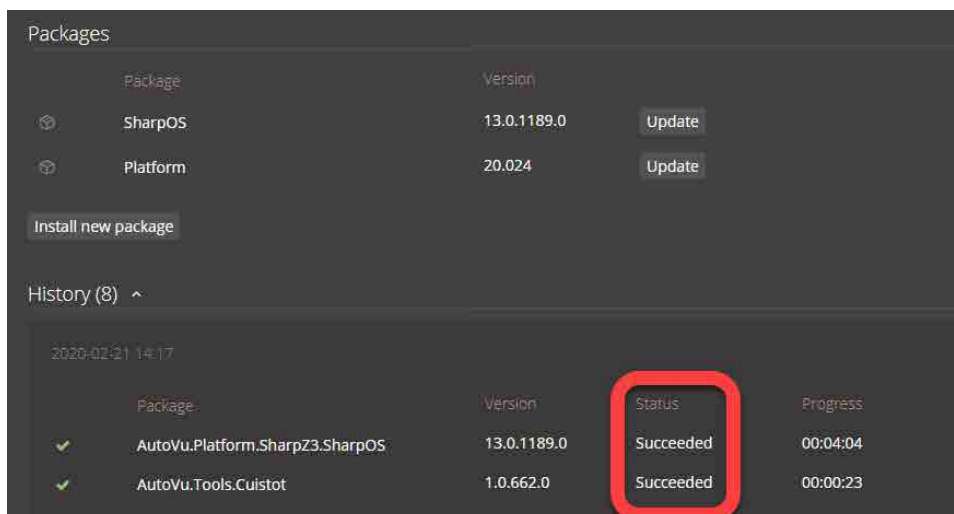

## After you finish

If you are updating a SharpZ3 system that includes a four-camera ALPR module, each group of two cameras is configured on a separate Sharp Portal. It is recommended that you update both portals at the same time. A link is provided at the top of the *Maintenance* page to direct you to the second Sharp Portal.

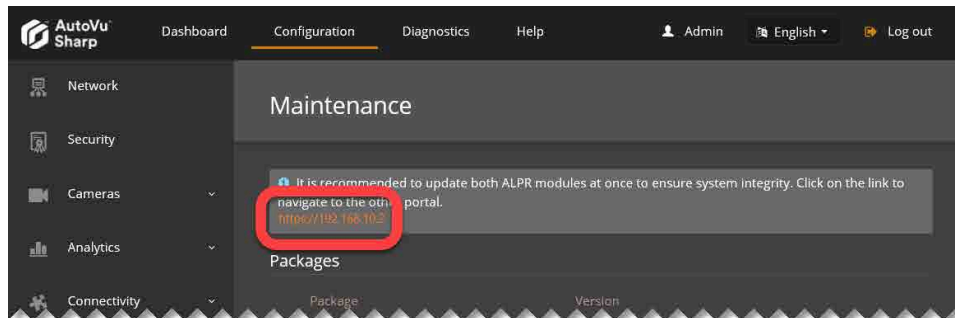

## Sharp Portal reference

This section includes the following topics:

- ["Sharp Portal - Overview page"](#) on page 181
- ["Sharp Portal - Camera feeds page"](#) on page 183
- ["Sharp Portal - Inventory page"](#) on page 185
- ["Sharp Portal - Network page"](#) on page 186
- ["Sharp Portal - Security page"](#) on page 187
- ["Sharp Portal - Exposure page"](#) on page 189
- ["Sharp Portal - Position and orientation page"](#) on page 190
- ["Sharp Portal - Auxiliary cameras page"](#) on page 191
- ["Sharp Portal - ALPR settings page"](#) on page 192
- ["Sharp Portal - Extension page"](#) on page 193
- ["Sharp Portal - Product improvement program page"](#) on page 195
- ["Sharp Portal - Recovery page"](#) on page 196
- ["Sharp Portal - Date and time page"](#) on page 197
- ["Sharp Portal - Power options page"](#) on page 198
- ["Sharp Portal - Maintenance page"](#) on page 199
- ["Sharp Portal - Logs page"](#) on page 200
- ["Sharp Portal - Log sources page"](#) on page 201

# Sharp Portal - Overview page

---

This section lists the settings found in the *Overview* page of the Sharp Portal and provides general information about the SharpZ3, such as serial number, license, IP address, input and relay status, and so on.

To navigate to the *Overview* page, click **Configuration** > **Overview**.

## Camera info

The following information is displayed:

- **Serial number:** Displays the SharpZ3 hardware serial number.
- **License:** Displays whether the SharpZ3 license is valid, invalid, or missing.
- **Inputs:** Displays the inputs on the SharpZ3 and whether the input is in a **High** or **Low** state. A high-state input is indicative of a voltage of 5.75 V or higher. A low-state input is indicative of a voltage of 4.80 V or lower.
- **Relays:** Displays the SharpZ3 relays and whether the relay state is **Opened** or **Closed**. The SharpZ3 has two 0.25 A solid-state relays and two 8 A electromechanical relays.
- **Test relays:** Click to toggle your configured relay between **Opened** and **Closed** to validate the configuration.
- **Mac address:** Displays the MAC address of the SharpZ3. This information might be requested if you contact technical support.
- **Type:** Displays the type of Sharp unit.
- **Platform:** Displays the software image installed on the SharpZ3. If you contact technical support, you might be asked to provide this number.
- **Version:**
  - **Software:** Displays the SharpOS version currently installed.
  - **Firmware:** Displays the update status of the Sharp unit.
  - **Details:** Provides additional information about the versions of the files and components included in the package.

Displays the SharpOS package version. You can use this information to confirm that your SharpZ3 is up to date.
- **Cameras:** Displays the resolution and the lens focal range available for cameras connected to the SharpZ3 unit.

## Connectivity

The following information is displayed:

- **IP addresses:** Displays the IPv4 and IPv6 address of the SharpZ3.
- **Internet:** Displays whether the SharpZ3 is connected to the Internet.

## Storage and usage

You can view information about reads stored on the SharpZ3, CPU usage, and memory usage. Indicator lines, usually green or orange, are provided so you can see the status. If an indicator line stays red for a prolonged period of time, it indicates either high CPU activity or that there is a problem.

- **Reads stored:** Indicates the reads stored in the database of the SharpZ3. The number of reads is also displayed.
- **Memory:** Displays information on the system's RAM memory.
- **CPU (Total):** Indicates the total CPU usage of the SharpZ3. Click **Show details** to see the usage for each CPU.

## Last activities

- **Unit rebooted:** Indicates the last time the unit was restarted.
- **Software restarted:** Indicates the last time the PlateReader software was restarted.

# Sharp Portal - Camera feeds page

---

This section lists the settings found in the *Camera feeds* page of the Sharp Portal. Use the *Camera feeds* page to view the live feeds of the context camera, ALPR camera, and auxiliary cameras.

**NOTE:** Some of the fields described in this section do not apply to auxiliary cameras.

To navigate to the *Camera feeds* page, click **Dashboard > Camera feeds**.

## Camera feeds

The **Camera feeds** section displays the live video feeds for any two of the connected camera units or auxiliary cameras such as wheel-imaging cameras. You can also view information about the live video feed such as the **FPS**, **Resolution**, **Exposure time**, and so on.

## Videos

- **Camera unit:** Select which Sharp camera or auxiliary camera to view.
- **Cameras:** Displays the resolution and the lens focal range available for cameras connected to the SharpZ3 unit.
- **Overlays:**
  - **Crosshairs:** Select this option to display crosshairs in the ALPR or context camera window.
  - **Bounding box:** Select this option to display the yellow bounding box around detected plates in the ALPR camera window.
- **Record:** Click the **Record** button to capture a series of context and ALPR images directly from the *Camera feeds* window and save them to your computer as a .zip file for debugging purposes.

### NOTE:

- Using the **Record** feature increases CPU usage.
- To use this feature, you cannot use the camera's auto-generated certificate. You must install a self-signed certificate that includes the IP address of the camera.

## Metadata

- **FPS (actual/average):** Displays the FPS of the context camera. This is the framerate processed by the LPR engine.
- **Resolution:** Displays the resolution of the camera's video feed.
- **Exposure time:** Displays the **Exposure** time of the video frame.
- **Gain:** Displays the **Gain** of the video frame.
- **Illuminator:** (Context camera only) Displays the intensity of light of the illuminator (as a percentage) on the Context camera.

## Last reads

- **Candidate:** Every read detected is displayed in this field as a potential read candidate. The camera can read up to 30 frames (reads) per second. The **Read strategy** configured on the **Analytics** page determines which read candidate will be used as the final read.

**NOTE:**

- The list contains the reads that have been made in this portal session. Exiting the session resets the list.
- The list is of limited length and older reads are automatically removed.
- Clicking on an entry pauses the list. Clicking Play resumes the list refresh and adds new reads that were received while the list was paused.
- The **Count** field accounts for all incoming reads and does not distinguish between camera units.

## Sharp Portal - Inventory page

---

This section lists the settings found in the *Inventory* page of the Sharp Portal. Use the *Inventory* page to view a list of hardware components along with their firmware versions and status.

To navigate to the *Inventory* page, click **Dashboard > Inventory**.

The following information is displayed:

**NOTE:** Additional functionality is available for certain hardware components, such as blinking the LED or connecting to a configuration portal.

- **Module:** Displays the name of the component.
- **Version:** Displays the component's firmware version.
- **Identification:** Displays a unique identifier of the component, such as its name or serial number.

**NOTE:** The serial number is also printed on the component sticker.

- **Status:** Displays the health status of the component.



# Sharp Portal - Network page

---

This section lists the settings found in the *Network* page of the Sharp Portal. Use the *Network* page to configure the SharpZ3 to use Dynamic Host Configuration Protocol (DHCP) or a static IP address.

## IPv4 network settings

To navigate to the *Network* page, click **Configuration > Network**.

- **Use DHCP:** If the patrol vehicle uses a DHCP server, you can configure the SharpZ3 system for DHCP. Consider the following:
  - When a SharpZ3 system is configured to use DHCP, the setting applies to the ALPR module, but does not apply to expansion modules. Expansion modules connected to the base unit always use static IP addresses that are defined on the *Network* page. For the expansion modules to work with the DHCP system, you must configure a compatible **Subnet mask** and **IP address** for each module.
  - When a SharpZ3 is configured in DHCP and the DHCP server cannot be reached, the default fall-back IPv4 address is 192.168.10.100. On a four-camera ALPR module, the second group of two cameras has a default fall-back address of 192.168.10.101.
 

**NOTE:** The default fallback takes at least two minutes to become effective when no DHCP server is detected at bootup.
- **Use static IP address:** If the SharpZ3 must use addresses withing a specific range, you can configure static addresses for the modules.
 

**IMPORTANT:** When assigning specific IP addresses, ensure the configuration stays compatible with the rest of the system, otherwise the base unit, expansion modules, or aux cameras might be unreachable. For example, it is important that all components be on the same subnet.

**IMPORTANT:** You must use a fixed IP address if you want to stream video to the Security Center Archiver role. You can do this using a static IP address or a reserved IP address on the DHCP server.
- **IP address:** Enter the new IP address you want to assign to the ALPR module. The default is 192.168.10.1 (port 1 and 2) and 192.168.10.2 (port 3 and 4).
- **Subnet mask:** Enter the new **Subnet mask** for the ALPR module, if applicable. The default is 255.255.255.0.
 

**IMPORTANT:** When assigning specific IP addresses, ensure the configuration stays compatible with the rest of the system, otherwise the base unit, expansion modules, or aux cameras might be unreachable. For example, it is important that all components be on the same subnet.
- **Gateway:** Enter the new **Gateway** for the ALPR module, if applicable. The default is 10.0.0.0.
- **DNS:** Enter the new **DNS** for the ALPR module, if applicable. The default is 10.0.0.0.

## EXP module settings

- **IP address:** Enter the new IP address you want to assign to the expansion module. The default IP address depends on which expansion slot the module is installed in.
- **Subnet mask:** Enter the new **Subnet mask** for the expansion module, if applicable. The default is 255.255.255.0.

# Sharp Portal - Security page

---

This section lists the settings found in the *Security* page of the Sharp Portal. Use the *Security* page to change the password and to manage certificates and permissions.

To navigate to the *Security* page, click **Configuration > Security**.

## Access

- **Modify password:** Click **Modify password** to change the password for the SharpZ3.

**NOTE:** If you forget your password, [you can reset it from the logon page](#).

## Certificate

Displays the signed and self-signed certificates that have been installed in the trusted root store of the SharpZ3. You can install multiple certificates and select which certificate to activate.

To activate a certificate, select the **Active** button for the certificate and click **Save and reboot**.

To delete a certificate click **X** and click **Save**.

**NOTE:** You can delete certificates, but you must leave at least one certificate on the SharpZ3.

- **+ Self-signed:** Click to create a self-signed certificate. In the *Create a self-signed certificate* dialog box, you must enter a two-letter **Country** code, the **Common name** of the SharpZ3, one or more **IP addresses**, and you must define the **Validity (in years)**. The other fields are optional.

### NOTE:

- If you use a self-signed certificate, you must also install the certificate on your client machine. For example, the machine used to log on to the Sharp Portal.
- If a certificate signature is issued by a certificate authority that is not included in the list of Windows of third-party root certificate authorities (CA), or if your organization has its own public key infrastructure (PKI) which manages signatures, you must add the CA to the platform software running on the SharpZ3 so that the host can validate the chain of trust. For more information, see [KBA-78971: Adding a certificate to a pre-12.8 SharpV from an unknown certificate authority](#) on the Genetec™ TechDoc Hub.
- **+ Signing request:** Click to create a certificate signing request. A certificate signing request must be created for your server before you can order a signed certificate from a trusted Certificate Authority. You must enter a two letter **Country** code, the **Common name** of the SharpZ3, and the **IP address** in the *Create a certificate signing request* dialog box. The other fields are optional.

**IMPORTANT:** If the SharpZ3 has been added to the Security Center Archiver and is being used to monitor video, you must enter the IP address of the SharpZ3 and not the SharpZ3 name.

**NOTE:** The signing request is deleted when the certificate is signed.

## Permissions

- **Accept remote reboot requests:** Select this option so that the SharpZ3 can be rebooted from Security Center.
- **Remote assistance:** Click **Enable for 1 hour** to grant remote access for technical support. The time and date when access expires is displayed.

**NOTE:** After one hour, the remote assistance session ends. If the AutoVu™ Support team needs additional time to resolve the issue, you can extend the remote assistance session.

## Unit

- **Run in covert mode:** Select this option to turn off the LED on the Sharp camera unit, making it less noticeable.

**IMPORTANT:** Selecting this option does not mean that the LED will never be illuminated. For example, if there is a serious error with the SharpZ3, the LED will blink to indicate that there is a problem.

- **Enable Read Trigger API compatibility mode:** Select this option if using software-trigger-activated reading in Security Center releases prior to 5.8.

## Sharp Portal - Exposure page

---

This section lists the settings found in the *Exposure* page of the Sharp Portal. Use the *Exposure* page to adjust the exposure of the license plates in the ALPR image.

To navigate to the *Exposure* page, click **Configuration > Cameras > Exposure**.

The following information is displayed:

- **Select your camera:** Select the camera to configure.
- **Exposure:** Choose from the following:
  - **Default:** Select this option to have the SharpZ3 automatically adjust the exposure settings.
  - **Fixed (indoor):** Select this option when constant lighting conditions are available. Use the sliders to adjust the **Gain** and **Exposure time**, until the overall brightness and clarity you want for the image is achieved.
  - **Range (outdoor):** Select this option for variable lighting conditions outdoors. Use the sliders to adjust the **Gain** and **Exposure time**, until the overall brightness and clarity you want for the image is achieved.
- **(Context camera only) Allow illuminator:** Select this to enable the IR illuminator in low light conditions. If **Exposure** is set to **Fixed (indoor)**, the IR illuminator is fixed to On or Off depending on **Allow illuminator** check box. If **Exposure** is set to **Range (outdoor)**, the illuminator is automatically turned On or Off depending on light conditions. However, the IR illuminator can be completely turned off by clearing the **Allow illuminator** check box.

# Sharp Portal - Position and orientation page

---

This section lists the settings found in the *Position and orientation* page of the Sharp Portal. Use the *Position and orientation* page to define SharpZ3 camera positions on the patrol vehicle roof.

To navigate to the *Position and orientation* page, click **Configuration** > **Cameras** > **Position and orientation**.

The following information is displayed:

- **Enable:** When enabled, the system estimates the GNSS position of the license plate of the target vehicle.

## Position

- **Left/right:** Define how far the camera is installed to the left (0 to -400 cm) or to the right (0 to 400 cm) of the GNSS antenna.
- **Rear/front:** Define how far the camera is installed to the rear (0 to -1000 cm) or to the front (0 to 1000 cm) of the GNSS antenna.
- **Below/above:** Define how far the camera is installed below (0 to -400 cm) or above (0 to 400 cm) the GNSS antenna.

## Orientation

- **Pan:** Define how far the camera is panned to the left (-90°) or to the right (90°) from a straight forward view (0°).
- **Tilt:** Define how far the camera is tilted to the up (45°) or down (-45°) from a level installation (0°).
- **Roll:** Define how far the camera is rolled counter-clockwise (-45°) or clockwise (45°) from a level installation (0°).

# Sharp Portal - Auxiliary cameras page

---

This section lists the settings found in the *Auxiliary cameras* page of the Sharp Portal. Use the *Auxiliary cameras* page to configure the ports of the SharpZ3 Aux PoE expansion module and to change PoE camera passwords.

To navigate to the *Auxiliary cameras* page, click **Configuration > Cameras > Auxiliary cameras**.

The following information is displayed:

## Wheel-imaging camera association

- **Camera Unit:** Lists the installed SharpZ3 camera units.
- **Associated AUX PoE camera:** You must associate the right and left wheel-imaging cameras with their respective SharpZ3 camera units. Select the PoE expansion module port where the associated wheel-imaging camera is connected.

**TIP:** If you are not sure which port a wheel-imaging camera is connected to, check the video feed for the auxiliary cameras in **Dashboard > Camera feeds**.

## Settings

- **Change camera password:** AutoVu™ auxiliary PoE cameras use the default Username: *admin* and Password: *1234*. If required by local regulations, you can change the camera password from the Sharp Portal instead of using the camera's web portal.

**IMPORTANT:** If you change the AUX PoE expansion module port connection after you change the password, you must reapply the password.

# Sharp Portal - ALPR settings page

---

This section lists the settings found in the *ALPR settings* page of the Sharp Portal. Use the *ALPR settings* page to configure the analytics used for the license plates read by the SharpZ3.

To navigate to the *ALPR settings* page, click **Configuration > Analytics > ALPR settings**.

The following information is displayed:

## Location

- **Context:** Select which plate origin the SharpZ3 is reading.

## Analytics:

- **State:** Select this option if you want the SharpZ3 unit to attempt read the license plate origin. Depending on the region, this can refer to the issuing state, province, or country.
- **Vehicle make:** Select this option if you want the SharpZ3 unit to attempt to read the vehicle's make from the brand or logo (Honda, Toyota, and so on).

**NOTE:** This setting is not recommended for MLPI installations.

- **Confidence score:** The SharpZ3 assigns a confidence score percentage to each license plate read. This value indicates how confident the SharpZ3 is in the accuracy of the read.

**NOTE:** License plates that contain similar characters such as *8* and *B* are more difficult to read and generally produce reads with a lower confidence score.

- **Vehicle type and color:** Select this option if you want to include the vehicle type and vehicle color with plate reads. Based on the context image, the Sharp unit can detect if the vehicle is a bus, passenger vehicle, motorcycle, pickup, truck, work van, or an unknown vehicle type. In addition, the Sharp unit can detect if the vehicle is black, white, blue, brown, green, gray, orange, red, or yellow. Colors excluding white and black are also assigned *light*, *neutral*, or *dark* according to the color analysis.

## Reads

- **Reading mode:** Select one of the following reading modes:
  - **Continuous:** Select this for plates to be captured continuously. This is the default setting.
  - **Conditional:** When this option is selected, the SharpZ3 captures plate reads continuously as long as the selected input signal meets the condition defined (high/low). You must select an input and specify whether the state is high or low.
  - **Multiconditional:** Generates reads from a specific camera only while an input's status meets the defined high or low condition. This option is required if using the AutoVu™ car camera switch.

## Read strategy

- **Slow moving vehicle:** Applicable for use in typical city, law enforcement, or mobile parking enforcement.
- **Fast moving vehicle:** Applicable for installations where vehicles travel at moderate to high speeds. For example, use this read strategy for law enforcement installations where vehicles might be traveling at high speeds in opposite directions.

## Sharp Portal - Extension page

---

This section lists the settings found in the *Extension* page of the Sharp Portal. Use the *Extension* page to configure where the SharpZ3 sends ALPR data.

To navigate to the *Extension* page, click **Configuration > Connectivity > Extension**.

The following information is displayed:

### Extension type: None

- **None:** Plate reads are stored locally on the SharpZ3 and can only be retrieved using the Reads API which is an external application.

### Extension type: FTP

Sends ALPR data to an FTP server. Configure the following:

- **Server:** Enter the server name and location of the FTP server.  
**NOTE:** The appropriate rights on that location must be granted to the chosen user on the FTP server. The target directory must also be present and be writable by that user.
- **Username:** Enter the username for the server.
- **Password:** Enter the password for the username.
- **Content Template:** ALPR data is sent in XML format, using the template shown. You can change certain elements if you choose.
- **Set default template:** Reverts to the default template values.
- **Export context images:** Export the context image (in JPEG format).
- **Export ALPR images:** Export the plate image (in JPEG format).
- **Retain data when the connection is lost:** Select this option for plate reads to be saved locally in the SharpZ3 database if the connection with the server is lost. The system attempts to reconnect with the server every 30 seconds. Stored reads are pushed to the server when the connection is reestablished.  
**IMPORTANT:** If there are any plate reads in the SharpZ3 database, clearing this check box and saving the configuration deletes the plate reads.
- **Send sample:** Verifies that the system can connect to the server and send a sample read file using the configured settings.

### HTTP / HTTPS

- **Server:** Enter the server name and location of the FTP server.  
**NOTE:** The appropriate rights on that location must be granted to the chosen user on the FTP server. The target directory must also be present and be writable by that user.
- **Format:** Select the format you want to send the ALPR data in. You can select either **JSON** or **XML** format.
- **Username:** Enter the username for the server.
- **Password:** Enter the password for the username.
- **Anonymize ALPR data:** The camera *hashes* the license plate using the SHA-1 algorithm. When you add an alphanumeric *salt (cryptography)* to the license plate number, it increases the security of the hashed output. Adding the same salt on all of the cameras in a network means that the same license plate produces an identical hash on all cameras. This allows the external system to recognize the identical hashes as a the same vehicle while still maintaining privacy.  
**IMPORTANT:** If the salt is changed after it is set, it must also be changed on all other cameras. Changing the salt breaks the link between old reads and new reads.
- **Ignore certificate errors:** Select this option when sending ALPR data to an HTTPS server that does not have a trusted certificate. The SharpZ3 does not send the ALPR data to an HTTPS server that does not have a trusted certificate unless you select this option.



- **Export context images:** Export the context image (in JPEG format).
  - **Export ALPR images:** Export the plate image (in JPEG format).
  - **Retain data when the connection is lost:** Select this option for plate reads to be saved locally in the SharpZ3 database if the connection with the server is lost. The system attempts to reconnect with the server every 30 seconds. Stored reads are pushed to the server when the connection is reestablished.
- IMPORTANT:** If there are any plate reads in the SharpZ3 database, clearing this check box and saving the configuration deletes the plate reads.

## Patroller

Sends ALPR data to Genetec Patroller™. Configure the following:

- **Discovery port:** Port on which the SharpZ3 listens for discovery requests. This port number must match the discovery port entered on the Genetec Patroller™ Config Tool *Cameras* page.

## Sharp Portal - Product improvement program page

---

This section lists the settings found in the *Product improvement program* page of the Sharp Portal. Use the *Product improvement program* page to configure the delay period to send images from SharpZ3 camera to servers at Genetec Inc.

To navigate to the *Product improvement program* page, click **Configuration > Connectivity > Product improvement**.

The following information is displayed:

### Product improvement program

- **Activate program:** Select one of the following activation modes:
  - **Not Active:** Select this option if you are not participating in the program.
  - **Always activated (recommended):** Select this option if you are participating in the program. When this option is selected, the SharpZ3 camera sends images to Genetec Inc. cloud systems continuously as long as there is an established connection.
  - **Activated for:** Select this option if you want send images for a support case. You can choose a delay period from the menu.  
**NOTE:** When a delay period has been selected and the program is active, an expiration date and time is displayed.
  - **Support case number (optional):** If you activate the program for a support case, enter the support case number provided by Genetec™ Technical Support.
- **Agreement:** Select the check box to agree to terms and conditions of the product improvement program feature.

# Sharp Portal - Recovery page

---

This section lists the settings found in the *Recovery* page of the Sharp Portal. Use the *Recovery* page to import or export settings and to configure a Syslog server.

To navigate to the *Recovery* page, click **Configuration > General settings > Recovery**.

The following information is displayed:

## Settings

- **Export diagnostics:** Export a file that includes SharpZ3 diagnostics and SharpZ3 settings.
  - **Export settings:** Exports configuration and diagnostic settings as a .zip file. You can use the .zip file for technical support, or you can import the settings to another Sharp unit for quick configuration
  - **Import settings:** Imports configuration settings from a .zip file exported from another Sharp. You can use this .zip file to quickly configure your Sharp. After you import the settings, the Plate Reader service restarts automatically.
- IMPORTANT:** You can only import settings from a similar Sharp (same model and SharpOS version).
- **Reset to factory default:** Click to reset the SharpZ3 to use the factory default settings. A message confirms the reset and offers to optionally clear the network settings as well. Note that some settings are never cleared, such as battery settings and certificates.

**NOTE:** The passwords for auxiliary cameras are not reset during a factory reset. You must reenter the passwords in **Configuration > Cameras > Auxiliary cameras**

## Syslog

- **Use Syslog server:** Select this option to configure a central repository for all SharpZ3 log entries.
  - **Server:** Enter the IP address or name of the server.  
**NOTE:** Syslog server configurations do not support IPv6 addresses.
  - **Port:** Enter the port number of the syslog server.
  - **Network protocol:** Select UDP or TCP.

## Sharp Portal - Date and time page

---

This section lists the settings found in the *Date and time* page of the Sharp Portal. Use the *Date and time* page to configure how you want to configure the internal clock of the SharpZ3.

To navigate to the *Date and time* page, click **Configuration > General settings > Date and time**.

The following information is displayed:

- **Settings:** Select one of the following settings.
  - **NTP server:** The camera synchronizes with an NTP server that is typically either a foreign computer or a server within your organization that synchronizes itself with an external NTP server. The latter is recommended if synchronization is crucial to your organization. Click **Server** and enter the URL or IPv4 address of the machine running the NTP server. Click **Test connection** to tests the connection between the camera and the NTP server. The camera synchronizes with the NTP server every hour.
  - **Active extension (Patroller):** If you select **Active extension (Patroller)**, the camera's date and time are synchronized with the Genetec Patroller™ server that the camera is connected to. The camera synchronizes with the server upon connection, then again every 10 minutes.  
**NOTE:** If you have not yet configured the active extension (see [Configuring where the SharpZ3 sends its ALPR data](#) on page 152), you can select **Active extension**, and it will be updated when you configure the extension.  
**NOTE:** The **Active extension** option displays whichever extension is currently selected for the camera in *Configuration > Extensions*, however, selecting this option has no effect if you are using an extension type other than Patroller (not valid for FTP, HTTP, and so on).
- **Date and time format:** Select the date and time format to be used in the Sharp Portal.
  - **International:** Selecting the International option displays the date and time in the format: YYYY-MM-DD HH:MM:SS
  - **Imperial:** Selecting the Imperial option displays the date and time in the format: DD/MM/YYYY H:MM:SS AM/PM

## Sharp Portal - Power options page

---

This section lists the settings found in the *Power options* page of the Sharp Portal. Use the *Power options* page to configure the camera based on the power grid of the installation location.

To navigate to the *Power options* page, click **Configuration > General settings > Power options**.

The following information is displayed:

- **Power line frequency:** Select the power line frequency that corresponds to the installation location.
  - **60 Hz:** Generally used in North America and South America
  - **50 Hz:** Generally used in Africa, Australia, Asia, and Europe

**NOTE:** For more information on the power line frequency used in your installation location, [click here](#).

**Advanced:**

- **Turn on voltage:** Input voltage threshold below which the unit does not turn on.
- **Ignition cut-off delay:** Grace period between ignition cut-off and trunk unit power-down.
- **Undervoltage:** Input undervoltage threshold that causes a unit shut-off if maintained for a certain time.

## Sharp Portal - Maintenance page

---

This section lists the settings found in the *Maintenance* page of the Sharp Portal. Use the *Maintenance* page to update software or reboot the unit.

To navigate to the *Maintenance* page, click **Configuration > Maintenance**.

The following information is displayed:

- **Update:** Update the SharpOS software or the platform OS with latest security updates.
- **Free up space:** Space is freed up by deleting log files, untransmitted reads, and clearing the update cache.
- **Reboot unit:** Click to restart the SharpZ3.

**NOTE:** If you are rebooting a SharpZ3 system that includes a four-camera ALPR module, each group of two cameras is configured on a separate Sharp Portal. Rebooting the unit only reboots the stack associated with the current portal. To reboot the entire system, you must power cycle the base unit.

- **Blink LED:** Click to blink the LED on the SharpZ3 for about a minute. This is useful when you have multiple units and you want to physically identify the one you are configuring.

## Sharp Portal - Logs page

---

This section lists the settings found in the *Logs* page of the Sharp Portal. Use the *Logs* page to run reports and generate logs about the status of the SharpZ3. You can filter by a specific source, message, and so on. Log reports can also be exported to a .zip file by selecting **Export settings** on the *Maintenance* page.

To navigate to the *Logs* page, click **Diagnostics > Logs**.

The following information is displayed:

- **Severity:** Click the icons to choose which severity types you want to include in the report query. You can choose from the following:
  - Error
  - Warning
  - Information
  - Debug
  - Performance
- **Source:** Select the source that you want to include in the report query.
- **Message:** Enter a message. Only logs containing the message string entered are displayed on the query.
- **Time:** Select a time range.
- **Search:** Click to run the query.
- **Pause:** Click to pause the auto-refresh on the query. This is useful when you want to stop new entries from coming in so you can focus on a particular entry. Click **Resume** to activate the auto-refresh on the query.
- **Download all logs in a text file:** Click to download in a text file.

**NOTE:** The filters on this page apply only to the visual report. The log file always contains a full, unfiltered list of events.

## Sharp Portal - Log sources page

---

This section lists the settings found in the *Log sources* page of the Sharp Portal. Use the *Log sources* page to activate sources and to specify the level of verbosity.

To navigate to the *Log sources* page, click **Diagnostics > Log sources**.

The following information is displayed:

- **Sources to log:** Select the sources from which to generate a log. For example, if you only want to generate log events related to Plate Reader, select **Plate Reader** from the list.

**NOTE:**

- A source that contains *Verbose* in its name might generate a lot of disk activity.
- When a log entry contains an exception, a small box icon is displayed under the **Exception** column. Click on the box to see the exception details.



# Glossary

<b>action</b>	An action is a user-programmable function that can be triggered as an automatic response to an event, such as door held open for too long or object left unattended, or that can be executed according to a specific time table.
<b>area</b>	An area entity represents a concept or a physical location (room, floor, building, site, and so on) used for grouping other entities in the system.
<b>automatic enrollment</b>	Automatic enrollment is when new IP units on a network are automatically discovered by and added to Security Center. The role that is responsible for the units <i>broadcasts</i> a discovery request on a specific port, and the units listening on that port respond with a message that contains the connection information about themselves. The role then uses the information to configure the connection to the unit and enable communication.
<b>AutoVu™</b>	The AutoVu™ automatic license plate recognition (ALPR) system automates license plate reading and identification, making it easier for law enforcement and for municipal and commercial organizations to locate vehicles of interest and enforce parking restrictions. Designed for both fixed and mobile installations, the AutoVu™ system is ideal for a variety of applications and entities, including law enforcement, municipal, and commercial organizations.
<b>AutoVu MLC™</b>	AutoVu MLC™ (Machine Learning Core) replaces traditional rule-based ALPR technology with machine learning-based algorithms to reduce common ALPR misreads and false positives. It is a proprietary technology of Genetec Inc. used in AutoVu™ Sharp hardware for license plate recognition.
<b>capture rate</b>	The capture rate measures the speed at which a license plate recognition system can take a photo of a passing vehicle and detect the license plate in the image.
<b>certificate</b>	Designates one of the following: (1) <i>digital certificate</i> ; (2) <i>SDK certificate</i> .
<b>Config Tool</b>	Config Tool is the Security Center administrative application used to manage all Security Center users and to configure all Security Center entities such as areas, cameras, doors, schedules, cardholders, patrol vehicles, LPR units, and hardware devices.
<b>context camera</b>	A context camera is a camera connected to an LPR unit that produces a wider angle color image of the vehicle whose license plate was read by the LPR camera.

<b>contract permit parking</b>	Contract permit parking is a parking scenario where only drivers with monthly permits can park in the parking zone. A whitelist is used to grant permit holders access to the parking zone.
<b>Copy configuration tool</b>	The Copy configuration tool helps you save configuration time by copying the settings of one entity to many others that partially share the same settings.
<b>covert hit</b>	A covert hit is a read (captured license plate) that is matched to a covert hotlist. Covert hits are not displayed on the Genetec Patroller™ screen, but can be displayed in Security Desk by a user with proper privileges.
<b>covert hotlist</b>	Covert hotlists allow you to ensure the discretion of an ongoing investigation or special operation. When a hit is identified, only the authorized officer at the Security Center station is notified, while the officer in the patrol vehicle is not alerted. This enables enforcement officials to assign multiple objectives to the vehicle and back-end systems, while not interrupting the priorities of officers on duty.
<b>custom event</b>	A custom event is an event added after the initial system installation. Events defined at system installation are called system events. Custom events can be user-defined or automatically added through plugin installations. Unlike system events, custom events can be renamed and deleted.
<b>custom field</b>	A custom field is a user-defined property that is associated with an entity type and is used to store additional information that is useful to your organization.
<b>Daily usage per Patroller</b>	Daily usage per Patroller is a type of investigation task that reports on the daily usage statistics of a selected patrol vehicle (operating time, longest stop, total number of stops, longest shutdown, and so on) for a given date range.
<b>dashboard</b>	A dashboard is one of the three panels that belong to the canvas in Security Desk. It contains the graphical commands (or widgets) pertaining to the entity displayed in the current tile.
<b>database server</b>	A database server is an application that manages databases and handles data requests made by client applications. Security Center uses Microsoft SQL Server as its database server.
<b>Directory</b>	The Directory role identifies a Security Center system. It manages all entity configurations and system-wide settings. Only a single instance of this role is permitted on your system. The server hosting the Directory role is called the <i>main server</i> , and must be set up first. All other servers you add in Security Center are called <i>expansion servers</i> , and must connect to the main server to be part of the same system.

<b>Directory Manager</b>	The Directory Manager role manages the Directory failover and load balancing in order to produce the high availability characteristics in Security Center.
<b>Directory server</b>	A Directory server is any one of the multiple servers simultaneously running the Directory role in a high availability configuration.
<b>discovery port</b>	A discovery port is a port used by certain Security Center roles (Access Manager, Archiver, LPR Manager) to find the units they are responsible for on the LAN. No two discovery ports can be the same on one system.
<b>district</b>	A district is a type of parking regulation characterizing an overtime rule. A district is a geographical area within a city. A vehicle is in violation if it is seen within the boundaries of the district over a specified period of time.
<b>enforce</b>	To enforce is to take action following a confirmed hit. For example, a parking officer can enforce a scofflaw violation (unpaid parking tickets) by placing a wheel boot on the vehicle.
<b>entity</b>	Entities are the basic building blocks of Security Center. Everything that requires configuration is represented by an entity. An entity can represent a physical device, such as a camera or a door, or an abstract concept, such as an alarm, a schedule, a user, a role, a plugin, or an add-on.
<b>entity tree</b>	An entity tree is the graphical representation of Security Center entities in a tree structure, illustrating the hierarchical nature of their relationships.
<b>event</b>	An event indicates the occurrence of an activity or incident, such as access denied to a cardholder or motion detected on a camera. Events are automatically logged in Security Center. Every event has an entity as its main focus, called the event source.
<b>event-to-action</b>	An event-to-action links an action to an event. For example, you can configure Security Center to trigger an alarm when a door is forced open.
<b>expansion server</b>	An expansion server is any server machine in a Security Center system that does not host the Directory role. The purpose of the expansion server is to add to the processing power of the system.
<b>failover</b>	Failover is a backup operational mode in which a role (system function) is automatically transferred from its primary server to a secondary server that is on standby. This transfer between servers occurs only if the primary server becomes unavailable, either through failure or through scheduled downtime.

<b>false positive read</b>	False positive plate reads can occur when a license plate recognition system mistakes other objects in an image for license plates. For example, lettering on a vehicle or street signs can sometimes create false positive plate reads.
<b>federated entity</b>	A federated entity is any entity that is imported from an independent system through one of the Federation™ roles.
<b>federated system</b>	A federated system is a independent system (Omnicast™ or Security Center) that is unified under your local Security Center via a Federation™ role, so that the local users can view and control its entities, as if they belong to the local system.
<b>Federation™</b>	The Federation™ feature joins multiple, independent Genetec™ IP security systems into a single virtual system. With this feature, Security Center users can view and control entities that belong to remote systems, directly from their local Security Center system.
<b>Fuzzy matching</b>	Environmental factors such as dirt or snow can partially obstruct license plate characters and increase the likelihood of partial plate reads occurring. In addition, similarly shaped letters and numbers, like “2” and “Z” or, “8”, “B”, and “0”, can also reduce plate read accuracy. Fuzzy matching lets AutoVu™ compare reads not only to exact matches in hotlists, but also to potential or probable matches.
<b>Genetec™ Server</b>	Genetec™ Server is the Windows service that is at the core of Security Center architecture, and that must be installed on every computer that is part of the Security Center's pool of servers. Every such server is a generic computing resource capable of taking on any role (set of functions) you assign to it.
<b>geocoding</b>	Geocoding is the process of finding associated geographic coordinates (latitude and longitude) from a street address.
<b>georeferencing</b>	Georeferencing is the process of using an object's geographic coordinates (latitude and longitude) to determine its position on a map.
<b>ghost Patroller</b>	A ghost Patroller is an entity automatically created by the LPR Manager when the AutoVu™ license includes the XML Import module. In Security Center, all LPR data must be associated to a Genetec Patroller™ entity or an LPR unit corresponding to a fixed Sharp camera. When you import LPR data from an external source via a specific LPR Manager using the XML Import module, the system uses the ghost entity to represent the LPR data source. You can formulate queries using the ghost entity as you would with a normal entity.
<b>Geographic Information System</b>	Geographic Information System (GIS) is a system that captures spatial geographical data. Map Manager can connect to third-party vendors that provide GIS services in order to bring maps

and all types of geographically referenced data to Security Center.

<b>Hardware inventory</b>	Hardware inventory is a type of maintenance task that reports on the characteristics (unit model, firmware version, IP address, time zone, and so on) of access control, video, intrusion detection, and LPR units in your system.
<b>hash function</b>	In cryptography, a hash function uses a mathematical algorithm to take input data and return a fixed-size alphanumeric string. A hash function is designed to be a one-way function, that is, a function which is infeasible to revert.
<b>hit</b>	A hit is a license plate read that matches a hit rule, such as a hotlist, overtime rule, permit, or permit restriction. A Genetec Patroller™ user can choose to reject or accept a hit. An accepted hit can subsequently be enforced.
<b>hit rule</b>	Hit rule is a type of LPR rule used to identify vehicles of interest (called "hits") using license plate reads. The hit rules include the following types: hotlist, overtime rule, permit, and permit restriction.
<b>Hits</b>	Hits is a type of investigation task that reports on hits reported within a selected time range and geographic area.
<b>hot action</b>	A hot action is an action mapped to a PC keyboard function key (Ctrl+F1 through Ctrl+F12) in Security Desk for quick access.
<b>hotlist</b>	A hotlist is a list of wanted vehicles, where each vehicle is identified by a license plate number, the issuing state, and the reason why the vehicle is wanted (stolen, wanted felon, Amber alert, VIP, and so on). Optional vehicle information might include the model, the color, and the vehicle identification number (VIN).
<b>Hotlist and permit editor</b>	Hotlist and permit editor is a type of operation task used to edit an existing hotlist or permit list. A new list cannot be created with this task, but after an existing list has been added to Security Center, users can edit, add, or delete items from the list, and the original text file is updated with the changes.
<b>illuminator</b>	An illuminator is a light in the Sharp unit that illuminates the plate, thereby improving the accuracy of the images produced by the LPR camera.
<b>incident</b>	An incident is an unexpected event reported by a Security Desk user. Incident reports can use formatted text and include events and entities as support material.
<b>Incidents</b>	Incidents is a type of investigation task that allows you to search, review, and modify incident reports.

<b>Inventory report</b>	Inventory report is a type of investigation task that allows you to view a specific inventory (vehicle location, vehicle length of stay, and so on) or compare two inventories of a selected parking facility (vehicles added, vehicles removed, and so on).
<b>I/O linking</b>	I/O (input/output) linking is controlling an output relay based on the combined state (normal, active, or trouble) of a group of monitored inputs. A standard application is to sound a buzzer (through an output relay) when any window on the ground floor of a building is shattered (assuming that each window is monitored by a "glass break" sensor connected to an input).
<b>IPv4</b>	IPv4 is the first generation Internet protocol using a 32-bit address space.
<b>IPv6</b>	IPv6 is a 128-bit Internet protocol that uses eight groups of four hexadecimal digits for address space.
<b>Law Enforcement</b>	Law Enforcement is a Genetec Patroller™ software installation that is configured for law enforcement: the matching of license plate reads against lists of wanted license plates (hotlists). The use of maps is optional.
<b>license key</b>	A license key is the software key used to unlock the Security Center software. The license key is specifically generated for each computer where the Directory role is installed. To obtain your license key, you need the <i>System ID</i> (which identifies your system) and the <i>Validation key</i> (which identifies your computer).
<b>license plate inventory</b>	A license plate inventory is a list of license plate numbers of vehicles found in a parking facility within a given time period, showing where each vehicle is parked (sector and row).
<b>license plate read</b>	A license plate read is a license plate number captured from a video image using LPR technology.
<b>license plate recognition</b>	License plate recognition (LPR) is an image processing technology used to read license plate numbers. LPR converts license plate numbers cropped from camera images into a database searchable format.
<b>live hit</b>	A live hit is a hit matched by the Genetec Patroller™ and immediately sent to the Security Center over a wireless network.
<b>live read</b>	A live read is a license plate captured by the patrol vehicle and immediately sent to Security Center over a wireless network.
<b>load balancing</b>	Load balancing is the distribution of workload across multiple computers.
<b>logical ID</b>	Logical ID is a unique ID assigned to each entity in the system for ease of reference. Logical IDs are only unique within a particular entity type.

<b>Logons per Patroller</b>	Logons is a type of investigation task that reports on the logon records of a selected patrol vehicle.
<b>long term</b>	Long term is a type of parking regulation characterizing an overtime rule. The <i>long term</i> regulation uses the same principle as the <i>same position</i> regulation, but the parking period starts on one calendar date and ends on another calendar date. No more than one overtime rule can use the long term regulation in the entire system.
<b>LPR camera</b>	A License Plate Recognition (LPR) camera is a camera connected to an LPR unit that produces high resolution close-up images of license plates.
<b>LPR context</b>	An LPR context is an LPR optimization that improves license plate recognition performance for license plates from a specific region (for example, New York) or from a group of regions (for example, Northeast states).
<b>LPR Manager</b>	The LPR Manager role manages and controls the patrol vehicle software (Genetec Patroller™), Sharp cameras, and parking zones. The LPR Manager stores the LPR data (reads, hits, timestamps, GPS coordinates, and so on) collected by the devices.
<b>SharpZ3 ALPR module</b>	ALPR modules are available for the SharpZ3 trunk unit which can support either two or four SharpZ3 cameras.
<b>LPR rule</b>	LPR rule is a method used by Security Center and AutoVu™ for processing a license plate read. An LPR rule can be a hit rule or a parking facility.
<b>LPR unit</b>	An LPR unit is a device that captures license plate numbers. An LPR unit typically includes a context camera and at least one LPR camera.
<b>macro</b>	A macro is a type of entity that encapsulates a C# program that adds custom functionalities to Security Center.
<b>main server</b>	The main server is the only server in a Security Center system hosting the Directory role. All other servers on the system must connect to the main server to be part of the same system. In a high availability configuration where multiple servers host the Directory role, it is the only server that can write to the Directory database.
<b>manual capture</b>	Manual capture is when license plate information is entered into the system by the user and not by the LPR.
<b>map link</b>	A map link is a map object that brings you to another map with a single click.
<b>map mode</b>	Map mode is a Security Desk canvas operating mode that replaces tiles and controls with a geographical map showing all

active, georeferenced events in your system. Switching to Map mode is a feature of AutoVu™ and Genetec Mission Control™, and requires a license for one of these products.

<b>map object</b>	Map objects are graphical representations of Security Center entities or geographical features, such as cities, highways, rivers, and so on, on your maps. With map objects, you can interact with your system without leaving your map.
<b>map view</b>	A map view is a defined section of a map.
<b>Mobile Data Computer</b>	Mobile Data Computer is a tablet computer or ruggedized laptop used in patrol vehicles to run the Genetec Patroller™ application. The MDC is typically equipped with a touch-screen with a minimum resolution of 800 x 600 pixels and wireless networking capability.
<b>Mobile License Plate Inventory</b>	Mobile License Plate Inventory (MLPI) is the Genetec Patroller™ software installation that is configured for collecting license plates and other vehicle information for creating and maintaining a license plate inventory for a large parking area or parking garage.
<b>Mobile Admin</b>	(Obsolete as of SC 5.8 GA) Mobile Admin is a web-based administration tool used to configure the Mobile Server.
<b>Mobile Server</b>	The Mobile Server role provides Security Center access on mobile devices.
<b>Monitoring</b>	The <i>Monitoring</i> task is a type of operation task that you can use to monitor and respond to real-time events that relate to selected entities. Using the <i>Monitoring</i> task, you can also monitor and respond to alarms.
<b>network</b>	The network entity is used to capture the characteristics of the networks used by your system so that proper stream routing decisions can be made.
<b>network address translation</b>	Network address translation is the process of modifying network address information in datagram (IP) packet headers while in transit across a traffic routing device, for the purpose of remapping one IP address space into another.
<b>network view</b>	The network view is a browser view that illustrates your network environment by showing each server under the network they belong to.
<b>new wanted</b>	A new wanted is a manually entered hotlist item in Genetec Patroller™. When you are looking for a plate that does not appear in the hotlists loaded in the Genetec Patroller™, you can enter the plate in order to raise a hit if the plate is captured.



<b>notification tray</b>	The notification tray contains icons that allow quick access to certain system features, and also displays indicators for system events and status information. The notification tray display settings are saved as part of your user profile and apply to both Security Desk and Config Tool.
<b>OCR equivalence</b>	OCR equivalence is the interpretation of OCR (Optical Character Recognition) equivalent characters performed during license plate recognition. OCR equivalent characters are visually similar, depending on the plate's font. For example, the letter "O" and the number "0", or the number "5" and the letter "S". There are several pre-defined OCR equivalent characters for different languages.
<b>SharpZ3 expansion module</b>	Up to three expansion modules can be added to the SharpZ3 base unit. The modules add additional functionality to the base system. For example, you can add modules for precise navigation, PoE ports for wheel imaging cameras, and so on.
<b>output behavior</b>	An output behavior is a type of entity that defines a custom output signal format, such as a pulse with a delay and duration.
<b>overtime rule</b>	An overtime rule is a type of entity that defines a parking time limit and the maximum number of violations enforceable within a single day. Overtime rules are used in city and university parking enforcement. For university parking, an overtime rule also defines the parking area where these restrictions apply.
<b>Parking Enforcement Essential</b>	Parking Enforcement Essential is a Genetec Patroller™ software installation configuration that is similar to the City Parking Enforcement configuration, but excludes features such as shared permits, zone auto-selection, Plate link, and wheel imaging. You can configure the system for either overtime enforcement or permit enforcement, but you cannot configure both enforcement types.
<b>parking facility</b>	A parking facility is a type of entity that defines a large parking area as a number of sectors and rows for the purpose of inventory tracking.
<b>parking lot</b>	A parking lot is a polygon that defines the location and shape of a parking area on a map. By defining the number of parking spaces inside the parking lot, Security Center can calculate its percentage of occupancy during a given time period.
<b>parking zone</b>	The parking zones that you define in Security Center represent off-street parking lots where the entrances and exits are monitored by Sharp cameras.
<b>partition</b>	A partition is a type of entity that defines a set of entities that are only visible to a specific group of users. For example, a

partition could include all areas, doors, cameras, and zones in one building.

**partition administrator**

(Obsolete) Beginning in Security Center 5.7 GA, privileges that used to be exclusive to administrators can now be granted individually, making the concept of *partition administrator* obsolete.

**patrol vehicle**

A patrol vehicle monitors parking lots and city streets for parking violations or wanted vehicles. A patrol vehicle includes one or more Sharp automatic license plate recognition (ALPR) cameras and an in-vehicle computer running Genetec Patroller™ software.

**Patroller**

1. Genetec Patroller™ is the AutoVu™ software application installed on an in-vehicle computer. Genetec Patroller™ connects to Security Center and is controlled by the LPR Manager. Genetec Patroller™ verifies license plates read from LPR cameras against lists of vehicles of interest (hotlists) and vehicles with permits (permit lists). It also collects data for time-limited parking enforcement. Genetec Patroller™ alerts you of hotlist or permit hits so that you can take immediate action.
2. Type of entity that represents a patrol vehicle equipped with an in-vehicle computer running Genetec Patroller™ software.

**Patroller Config Tool**

Genetec Patroller™ Config Tool is the Genetec Patroller™ administrative application used to configure Patroller-specific settings, such as adding Sharp cameras to the in-vehicle LAN, enabling features such as Manual Capture or New Wanted, and specifying that a username and password are needed to log on to Genetec Patroller™.

**Patroller tracking**

Patroller tracking is a type of investigation task that allows you to replay the route followed by a patrol vehicle on a given date on a map, or view the current location of patrol vehicles on a map.

**permit**

A permit is a type of entity that defines a single parking permit holder list. Each permit holder is characterized by a category (permit zone), a license plate number, a license issuing state, and optionally, a permit validity range (effective date and expiry date). Permits are used in both city and university parking enforcement.

**permit hit**

A permit hit is a hit that is generated when a read (license plate number) does not match any entry in a permit or when it matches an invalid permit.

**permit restriction**

A permit restriction is a type of entity that applies time restrictions to a series of parking permits for a given parking area. Permit restrictions can be used by patrol vehicles

configured for University Parking Enforcement and for systems that use the AutoVu™ Free-Flow feature.

**Plate link**

When a patrol vehicle that is registered with Plate link enters a parking zone, it downloads all recent plate reads and hits from other patrol vehicles that are registered with the same account. This data sharing ensures that the system catches parking violations that would otherwise be missed.

**Plate Reader**

Plate Reader is the software component of the Sharp unit that processes the images captured by the LPR camera to produce license plate reads, and associates each license plate read with a context image captured by the context camera. The Plate Reader also handles the communications with the Genetec Patroller™ and the LPR Manager. If an external wheel imaging camera is connected to the Sharp unit, the Plate Reader also captures wheel images from this camera.

**plugin**

A plugin (in lowercase) is a software component that adds a specific feature to an existing program. Depending on the context, plugin can refer either to the software component itself or to the software package used to install the software component.

**plugin role**

A plugin role adds optional features to Security Center. A plugin role is created by using the *Plugin* role template. By default, it is represented by an orange puzzle piece in the *Roles* view of the *System* task. Before you can create a plugin role, the software package specific to that role must be installed on your system.

**primary server**

Primary server is the default server chosen to perform a specific function (or role) in the system. To increase the system's fault-tolerance, the primary server can be protected by a secondary server on standby. When the primary server becomes unavailable, the secondary server automatically takes over.

**private IP address**

A private IP address is an IP address chosen from a range of addresses that are only valid for use on a LAN. The ranges for a private IP address are: 10.0.0.0 to 10.255.255.255, 172.16.0.0 to 172.16.255.255, and 192.168.0.0 to 192.168.255.255. Routers on the Internet are normally configured to discard any traffic using private IP addresses.

**private task**

A private task is a saved task that is only visible to the user who created it.

**privilege**

Privileges define what users can do, such as arming zones, blocking cameras, and unlocking doors, over the part of the system they have access rights to.

**public task**

A public task is a saved task that can be shared and reused among multiple Security Center users.

<b>read rate</b>	The read rate measures the speed at which a license plate recognition system can correctly detect and read all of the characters in an image of a license plate.
<b>Reads</b>	Reads is a type of investigation task that reports on license plate reads performed within a selected time range and geographic area.
<b>Reads/hits per day</b>	Reads/hits per day is a type of investigation task that reports on license plate reads performed within a selected time range and geographic area.
<b>Reads/hits per zone</b>	Reads/hits per zone is a type of investigation task that reports on the number of reads and hits per parking area for a selected date range.
<b>Report Manager</b>	Report Manager is a type of role that automates report emailing and printing based on schedules.
<b>report pane</b>	Report pane is one of the panes found in the Security Desk task workspace. It displays query results or real-time events in a tabular form.
<b>reverse geocoding</b>	Reverse geocoding is an AutoVu™ feature that translates a pair of latitude and longitude into a readable street address.
<b>role</b>	A role is a software component that performs a specific job within Security Center. To execute a role, you must assign one or more servers to host it.
<b>salt (cryptography)</b>	In cryptography, a salt is data that is used as an additional input to the information you want to encrypt or protect with a hash function, so that the original information is nearly impossible to guess, even when the attacker knows what algorithm is being used.
<b>same position</b>	Same position is a type of parking regulation characterizing an overtime rule. A vehicle is in violation if it is seen parked at the exact same spot over a specified period of time. Genetec Patroller™ must be equipped with GPS capability in order to enforce this type of regulation.
<b>schedule</b>	A schedule is a type of entity that defines a set of time constraints that can be applied to a multitude of situations in the system. Each time constraint is defined by a date coverage (daily, weekly, ordinal, or specific) and a time coverage (all day, fixed range, daytime, and nighttime).
<b>scheduled task</b>	A scheduled task is a type of entity that defines an action that executes automatically on a specific date and time, or according to a recurring schedule.

<b>Software Development Kit</b>	The Software Development Kit (SDK) allows end-users to develop custom applications or custom application extensions for Security Center.
<b>secondary server</b>	A secondary server is any alternate server on standby intended to replace the primary server in the case the latter becomes unavailable.
<b>Security Center</b>	Security Center is a truly unified platform that blends IP video surveillance, access control, license plate recognition, intrusion detection, and communications within one intuitive and modular solution. By taking advantage of a unified approach to security, your organization becomes more efficient, makes better decisions, and responds to situations and threats with greater confidence.
<b>Security Center Federation™</b>	The Security Center Federation™ role connects a remote, independent Security Center system to your local Security Center. That way, the remote system's entities and events can be used in your local system.
<b>Security Desk</b>	Security Desk is the unified user interface of Security Center. It provides consistent operator flow across all of the Security Center main systems, Omnicast™, Synergis™, and AutoVu™. The unique task-based design of Security Desk lets operators efficiently control and monitor multiple security and public safety applications.
<b>server</b>	A server is a type of entity that represents a server machine on which the Genetec™ Server service is installed.
<b>Server Admin</b>	Server Admin is the web application running on every server machine in Security Center that allows you to configure the settings of Genetec Server. Server Admin also allows you to configure the Directory role on the main server.
<b>SharpOS</b>	SharpOS is the software component of a Sharp unit. SharpOS is responsible for everything related to plate capture, collection, processing, and analytics. For example, a SharpOS update can include new LPR contexts, new firmware, Sharp Portal updates, and updates to the Sharp's Windows services (Plate Reader, HAL, and so on).
<b>Sharp Portal</b>	Sharp Portal is a web-based administration tool used to configure Sharp cameras for AutoVu™ systems. From a web browser, you log on to a specific IP address (or the Sharp name in certain cases) that corresponds to the Sharp you want to configure. When you log on, you can configure options such as selecting the ALPR context (for example, Alabama, Oregon, Quebec), selecting the read strategy (for example, fast moving or slow moving vehicles), viewing the Sharp's live video feed, and more.

<b>Sharp unit</b>	The Sharp unit is a proprietary LPR unit of Genetec Inc. that integrates license plate capturing and processing components, as well as digital video processing functions, inside a ruggedized casing.
<b>SharpZ3</b>	SharpZ3 is a proprietary mobile ALPR system designed by Genetec Inc. that integrates license plate cameras and a trunk unit that is responsible for ALPR processing as well as communication with the Genetec Patroller™ software running on the in-vehicle computer.
<b>SharpZ3 ALPR module</b>	ALPR modules are available for the SharpZ3 trunk unit which can support either two or four SharpZ3 cameras.
<b>SharpZ3 base unit</b>	The SharpZ3 base unit is the processing component of the SharpZ3 system. The base unit includes the ALPR module and up to three expansion modules that are used to add features to the system such as precise navigation, PoE ports for wheel imaging cameras, and so on.
<b>SharpZ3 expansion module</b>	Up to three expansion modules can be added to the SharpZ3 base unit. The modules add additional functionality to the base system. For example, you can add modules for precise navigation, PoE ports for wheel imaging cameras, and so on.
<b>standard schedule</b>	A standard schedule is a type of schedule entity that may be used in all situations. Its only limitation is that it does not support daytime or nighttime coverage.
<b>system event</b>	A system event is a predefined event that indicates the occurrence of an activity or incident. System events are defined by the system and cannot be renamed or deleted.
<b>System status</b>	System status is a type of maintenance task that monitors the status of all entities of a given type in real time, and allows you to interact with them.
<b>task</b>	A task is the central concept on which the entire Security Center user interface is built. Each task corresponds to one aspect of your work as a security professional. For example, use a monitoring task to monitor system events in real-time, use an investigation task to discover suspicious activity patterns, or use an administration task to configure your system. All tasks can be customized and multiple tasks can be carried out simultaneously.
<b>taskbar</b>	A taskbar is a user interface element of the Security Center client application window, composed of the Home tab and the active task list. The taskbar can be configured to appear on any edge of the application window.
<b>task workspace</b>	A task workspace is an area in the Security Center client application window reserved for the current task. The

workspace is typically divided into the following panes: canvas, report pane, controls, and area view.

<b>tile</b>	A tile is an individual window within the canvas, used to display a single entity. The entity displayed is typically the video from a camera, a map, or anything of a graphical nature. The look and feel of the tile depends on the displayed entity.
<b>timeline</b>	A timeline is a graphic illustration of a video sequence, showing where in time, motion, and bookmarks are found. Thumbnails can also be added to the timeline to help the user select the segment of interest.
<b>transient parking</b>	Transient parking is a parking scenario where the driver must purchase parking time as soon as the vehicle enters the parking lot.
<b>unit</b>	<p>A unit is a hardware device that communicates over an IP network that can be directly controlled by a Security Center role. We distinguish four types of units in Security Center:</p> <ul style="list-style-type: none"><li>• Access control units, managed by the Access Manager role</li><li>• Video units, managed by the Archiver role</li><li>• LPR units, managed by the LPR Manager role</li><li>• Intrusion detection units, managed by the Intrusion Manager role</li></ul>
<b>Unit replacement</b>	Unit replacement is a tool that is used to replace a failed hardware device with a compatible one, while ensuring that the data associated to the old unit gets transferred to the new one. For an access control unit, the configuration of the old unit is copied to the new unit. For a video unit, the video archive associated to the old unit is now associated to the new unit, but the unit configuration is not copied.
<b>University Parking Enforcement</b>	University Parking Enforcement is a Genetec Patroller™ software installation that is configured for university parking enforcement: the enforcement of scheduled parking permits or overtime restrictions. The use of maps is mandatory. Hotlist functionality is also included.
<b>unreconciled read</b>	A unreconciled read is a MLPI license plate read that has not been committed to an inventory.
<b>user</b>	A user is a type of entity that identifies a person who uses Security Center applications and defines the rights and privileges that person has on the system. Users can be created manually or imported from an Active Directory.
<b>user group</b>	A user group is a type of entity that defines a group of users who share common properties and privileges. By becoming member of a group, a user automatically inherits all the

properties of the group. A user can be a member of multiple user groups. User groups can also be nested.

**user level**

A user level is a numeric value assigned to users to restrict their ability to perform certain operations, such as controlling a camera PTZ, viewing the video feed from a camera, or staying logged on when a threat level is set. Level 1 is the highest user level, with the most privileges.

**validation key**

A validation key is a serial number uniquely identifying a computer that must be provided to obtain the license key.

**vehicle identification number**

A vehicle identification number (VIN) is an identification number that a manufacturer assigns to vehicles. This is usually visible from outside the vehicle as a small plate on the dashboard. A VIN can be included as additional information with license plate entries in a hotlist or permit list, to further validate a hit and ensure that it is the correct vehicle.

**wheel imaging**

Wheel imaging is a virtual tire-chalking technology that takes images of the wheels of vehicles to prove whether they have moved between two license plate reads.

**whitelist**

A whitelist is a hotlist that is created for the purpose of granting a group of license plates access to a parking lot. A whitelist can be compared to an access rule where the secured area is the parking lot. Instead of listing the cardholders, the whitelist applies to license plate credentials.

**widget**

A widget is a component of the graphical user interface (GUI) with which the user interacts.

**Zone occupancy**

Zone occupancy is a type of investigation task that reports on the number of vehicles parked in a selected parking area, and the percentage of occupancy.



# Where to find product information

You can find our product documentation in the following locations:

- **Genetec™ TechDoc Hub:** The latest documentation is available on the TechDoc Hub. To access the TechDoc Hub, log on to [Genetec™ Portal](#) and click [TechDoc Hub](#). Can't find what you're looking for? Contact [documentation@genetec.com](mailto:documentation@genetec.com).
- **Installation package:** The Installation Guide and Release Notes are available in the Documentation folder of the installation package. These documents also have a direct download link to the latest version of the document.
- **Help:** Security Center client and web-based applications include help, which explains how the product works and provide instructions on how to use the product features. To access the help, click **Help**, press F1, or tap the ? (question mark) in the different client applications.

# Technical support

Genetec™ Technical Assistance Center (GTAC) is committed to providing its worldwide clientele with the best technical support services available. As a customer of Genetec Inc., you have access to TechDoc Hub, where you can find information and search for answers to your product questions.

- **Genetec™ TechDoc Hub:** Find articles, manuals, and videos that answer your questions or help you solve technical issues.

Before contacting GTAC or opening a support case, it is recommended to search TechDoc Hub for potential fixes, workarounds, or known issues.

To access the TechDoc Hub, log on to [Genetec™ Portal](#) and click [TechDoc Hub](#). Can't find what you're looking for? Contact [documentation@genetec.com](mailto:documentation@genetec.com).

- **Genetec™ Technical Assistance Center (GTAC):** Contacting GTAC is described in the Genetec™ Lifecycle Management (GLM) documents: [Genetec™ Assurance Description](#) and [Genetec™ Advantage Description](#).

## Additional resources

If you require additional resources other than the Genetec™ Technical Assistance Center, the following is available to you:

- **Forum:** The Forum is an easy-to-use message board that allows clients and employees of Genetec Inc. to communicate with each other and discuss many topics, ranging from technical questions to technology tips. You can log on or sign up at <https://gtapforum.genetec.com>.
- **Technical training:** In a professional classroom environment or from the convenience of your own office, our qualified trainers can guide you through system design, installation, operation, and troubleshooting. Technical training services are offered for all products and for customers with a varied level of technical experience, and can be customized to meet your specific needs and objectives. For more information, go to <http://www.genetec.com/support/training/training-calendar>.

## Licensing

- For license activations or resets, please contact GTAC at <https://gtap.genetec.com>.
- For issues with license content or part numbers, or concerns about an order, please contact Genetec™ Customer Service at [customerservice@genetec.com](mailto:customerservice@genetec.com), or call 1-866-684-8006 (option #3).
- If you require a demo license or have questions regarding pricing, please contact Genetec™ Sales at [sales@genetec.com](mailto:sales@genetec.com), or call 1-866-684-8006 (option #2).

## Hardware product issues and defects

Please contact GTAC at <https://gtap.genetec.com> to address any issue regarding Genetec™ appliances or any hardware purchased through Genetec Inc.